

**LIGHTNING**

AN SPX BRAND

Packaging - Processing  
**Bid on Equipment**  
1-847-683-7720  
[www.bid-on-equipment.com](http://www.bid-on-equipment.com)

# Enhanced Classic Line ECL Portable Mixers



**SPX**®

# The Highest Performance, Quality Range of Portable Mixers

## LIGHTNIN ECL

The LIGHTNIN Classic Mixer has consistently evolved and improved through the years. These upgrades have provided mixer performance and enhanced process results. The Enhanced Classic Line (ECL) portable mixer gives our customers an even stronger and more flexible product. Never before has there been a range of portable mixers offering so much quality and value.

Maintenance free operation. All shaft bearings are sealed for life. Gears are synthetic grease lubricated for continuous lifetime service.

A mixer duty motor with standard mounting allows for many speed and enclosure variations.

Aluminum housing designed for high strength and low weight using Finite Element Analysis.

Large output shaft bearings for longer allowable shaft lengths and long life.

Safe positive chuck design prevents the shaft from disconnecting unless intentionally released. All hardware is captive to the chuck preventing loss.

The A310 is designed to produce excellent flow and process results at less power than other axial flow impellers.

Motor handle for ease of positioning the mixer and installation.

Unique motor coupling protects the gearing from shock torque loads and increases motor bearing life.

Two interchangeable planetary gear ratios provide more output speeds and increased process flexibility. Direct drive also available.

Multiple bearing seals prevent leakage of lubricant.

A convenient clamp indexing and locking system ensures precise, repeatable positioning for your unique application.

Strong, rugged clamp with slotted stabilizing wings and four point clamping for secure hold to the tank.

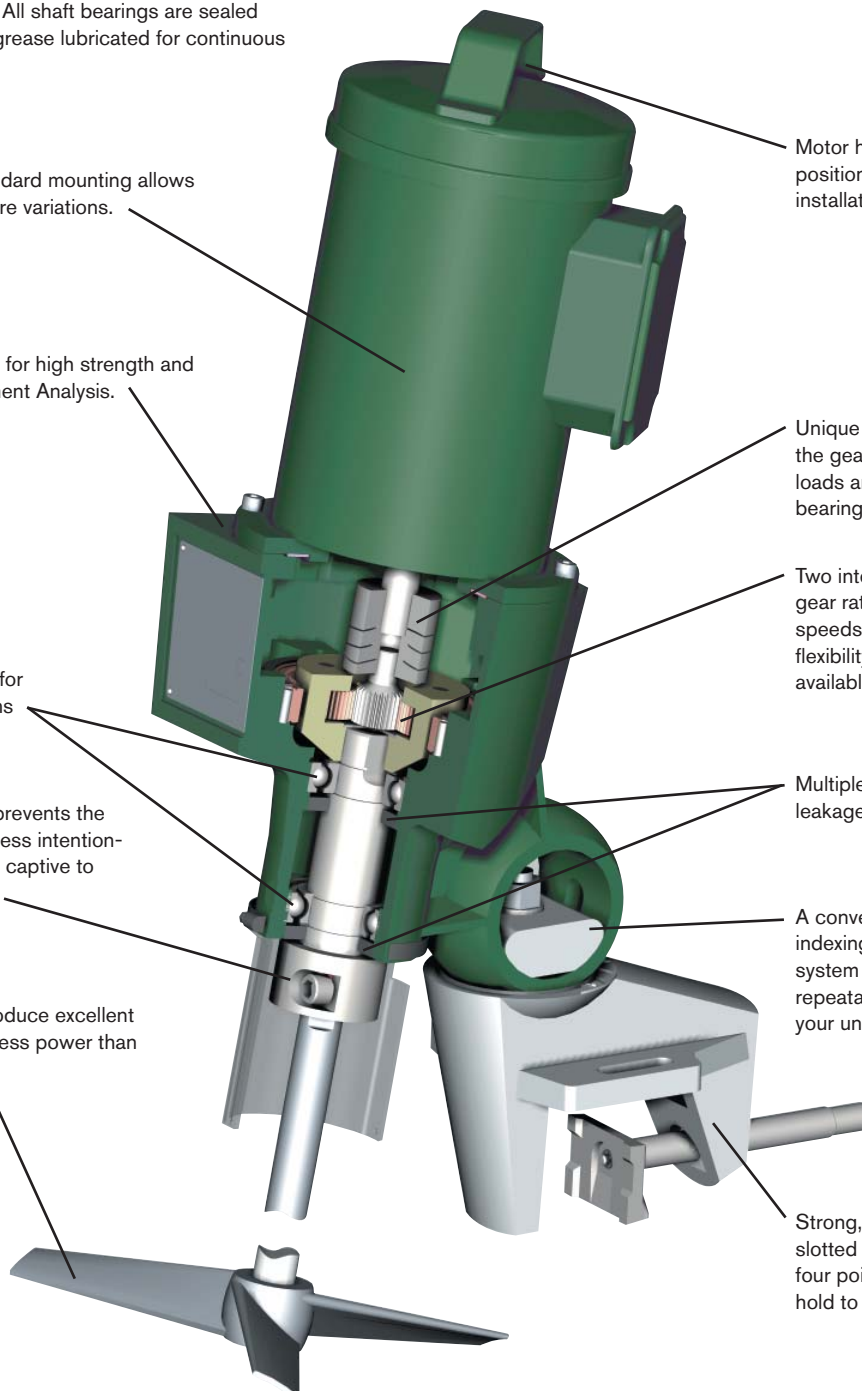

## ECL Options

- Stainless steel housing for clean applications
- Rigid coupling shaft attachment with male/female pilot to ensure shaft concentricity and minimize shaft run out
- Tachometer can be mounted local or remote and provides a LCD of mixer output speed. A 4 to 20 ma output signal is available for process control
- Variable speed control - VFD or Mechanical



## Impeller Options

LIGHTNIN is the world leader of impeller development. Using the latest computerized technology, LIGHTNIN has produced a unique range of impellers dedicated to improving your specific process performance.

Although the A310 is standard on ECL portables, there are many other impellers to satisfy your mixing requirements. Your LIGHTNIN Sales Engineer will review your application and recommend the proper impeller.



## ECL Motor Options

- **Electric Motors**  
A variety of enclosures, single or three phase, multiple voltage, and severe duty options are also available.



- **Air Motors**  
Variable speed air motors are safe for explosive environments. They are supplied with a built-in speed adjustment, air control valve and an option for non-lubricated vanes. Options include air filters, lubricators, and pressure regulators.



## Mounting Options

- A Finite Element Analysis designed heavy-duty clamp assembly provides maximum strength
- The cup plate option offers a more permanent mounting
- Clear index allows repeatable position
- Four point clamp action for secure hold on tank



With every agitator purchase, LIGHTNIN customers receive a product that has the built-in value of years of mixing experience in almost every known fluid mixing application.

### Portable ECL Gear and Direct Drive

MOUNTING HOLES 0.71

OPTIONAL CUP PLATE

Dimensions are in inches

HP	A	B	C	D	E	F	G	H	J	K	L	APPROX. WEIGHT ( . )
0.25 - 0.5	23.2	5.0	7.4	5.8	5.0	2.9	5.3	7.0	2.0	0.5	2.2	81
0.75 - 1.5	24.2	5.0	6.1	6.4	5.1	3.8	5.7	8.5	2.0	0.7	2.4	122
2 - 3	25.2	5.0	5.9	7.0	5.7	3.8	6.9	8.5	2.5	0.7	3.0	185

## LIGHTNIN Aftermarket Services

### Fastest Route to Uptime

**Expertise:** Experienced technicians are the backbone of our dedicated service organization. They're uniquely qualified to keep your LIGHTNIN mixers running right.

**LIGHTNIN Certified Technicians:** Aftermarket technicians are certified via training courses to ensure that the work they do meets the highest standards for consistency and reliability.

**Genuine LIGHTNIN Parts:** All repairs follow original design specs and use only factory-authorized replacement parts.

**Full LIGHTNIN Factory Warranty:** We're so confident we'll do the job right that all authorized repair and service work is covered by a full factory warranty.

- Factory Service Program
- Exchange Program = Minimal Downtime
- Quick Turnaround

## Call the LIGHTNIN Experts

For more information about the LIGHTNIN ECL or to discuss your application, contact your local SPX Process Equipment Sales Representative. Or visit our website at [www.spxpe.com](http://www.spxpe.com). Or call 1-888-MIX-BEST (U.S. and Canada)

# SPX<sup>®</sup>

## PROCESS EQUIPMENT

SPX Process Equipment, LIGHTNIN Operation  
 135 Mt. Read Blvd., Rochester, NY 14611  
 Phone: (888) 649-2378 (MIX-BEST), (U.S. and Canada) or +1 (585) 436-5550  
 E-mail: [LIGHTNIN@spx.com](mailto:LIGHTNIN@spx.com)

**Packaging - Processing**  
**Bid on Equipment**  
 1-847-683-7720  
[www.bid-on-equipment.com](http://www.bid-on-equipment.com)

For more information about our worldwide locations, approvals, certifications, and local representatives, please visit [www.spxpe.com](http://www.spxpe.com).

SPX Corporation reserves the right to incorporate our latest design and material changes without notice or obligation. Design features, materials of construction and dimensional data, as described in this bulletin, are provided for your information only and should not be relied upon unless confirmed in writing.