

# BioMixer

## Unmatched technology for sealed vessel applications

The LIGHTNIN BioMixer is ideally suited to biological and pharmaceutical processes, sanitary duties and mobile vessel applications. This modular mixing system addresses the mixing needs of sterile environments by using patented design concepts, microprocessor technology, robust power and advanced, laser-designed impellers. Custom software produces consistent results and accurately records data that is critical to both validation and scale-up.

### Designed for Sanitary Environments

- Autoclavable-in-place (lower assembly)
- FDA grade, non-cytotoxic materials
- Easy to install on sanitary flanged vessels
- Mixer seals vessel to minimize contamination
- Patented design

### NEW! MixWare 1.0 Computer Controlled Software

- Control software operates up to 32 mixers from one computer
- Simple computer connection
- 8 critical fluid mixing scale-up parameters recorded
- Validation data easily exported
- Temperature probe included
- All cables and connection hardware included
- [www.mixwaresupport.com](http://www.mixwaresupport.com)  
For FREE Upgrade from Mixer Connect

### An Exceptionally Versatile Mixing System

- Single detachable drive head mixes multiple vessels
- Largest mixing capacities in the industry
- Reversible rotation for up- or down-pumping experiments
- Patented mixing impellers provide efficiency
- Repeatable digital data entry via splash proof keypad
- Displays speed, power, torque, impeller flow and time
- Chemically resistant sanitary housing
- World-wide design, single phase 50 or 60 Hz



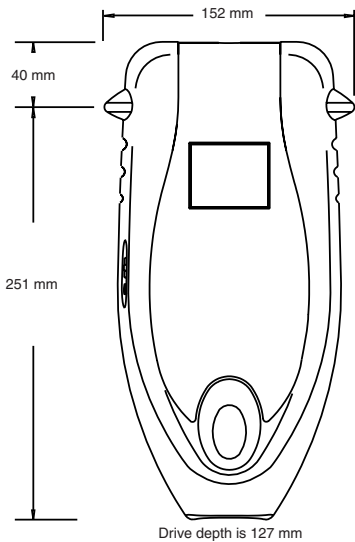

### BioMixer Drive Assemblies

Model	Catalog No.		Power (W)	Speed (RPM)
	115V/60HZ/1PH	230V/50HZ/1PH		
B7G04	836279	836286	40	20-250
B7G10	836280	836287	115	20-140
B4G10	836308	836305	115	20-550
<b>Computer Controlled</b>				
B7G04F	836309	836306	40	20-250
B7G10F	836310	836307	115	20-140
B4G10F	836281	836288	115	20-550

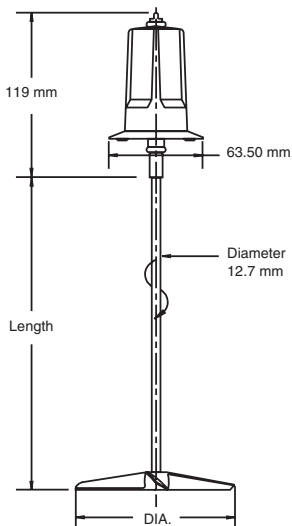

### BioMixer Lower Assemblies

Model	Catalog Number	Shaft Length		A310 Dia		Volume (L)	Matching Drive Assembly
		(mm)	(inches)	(mm)	(inches)		
B7B12	871040	343	13.5	102	4	12	B7G04
B7W50	834865	483	19	155	6.1	50	B7G04
B7W75	871041	584	23	160	6.3	75	B7G04
B7W115	871038	762	30	173	6.8	115	B7G10
B7W200	834866	813	32	224	8.8	200	B7G10
B7W210	871037	813	32	224	8.8	210	B7G10
B7W380	871039	965	38	254	10	380	B7G10
B7S380	835243	813	32	254	10	380	B7G10

## Worldwide commitment: International certification

These products are CE marked for the European Community, UL listed for the USA, CSA certified for Canada and T marked for Japan. In addition, they are ETL listed and certified for many other countries.

## Call the LIGHTNIN experts

For more information about the BioMixer or to discuss your application, contact your local LIGHTNIN Sales Representative. Or visit our website at [www.spxpe.com](http://www.spxpe.com). Or call 1-888-649-2378 (888-MIX-BEST) (U.S. and Canada) OR +1 (585) 527-5550 (worldwide).

## SPX Process Equipment

For more information about our worldwide locations, approvals, certifications, and local representatives, please visit our web site.  
**Web Site:** [www.spxprocessequipment.com](http://www.spxprocessequipment.com) • **E-Mail:** [lightnin@processequipment.spx.com](mailto:lightnin@processequipment.spx.com)

135 Mt. Read Blvd., Rochester, NY 14611 Telephone: (888) 649-2378 (888-MIX-BEST), (U.S. and Canada) or +1 (585) 436-5550 (Worldwide)

SPX Process Equipment reserves the right to incorporate our latest design and material changes without notice or obligation. Design features, materials of construction and dimensional data, as described in this bulletin, are provided for your information only and should not be relied upon unless confirmed in writing. Certified drawings are available upon request.  
 Issued: B-902-L-04/07