

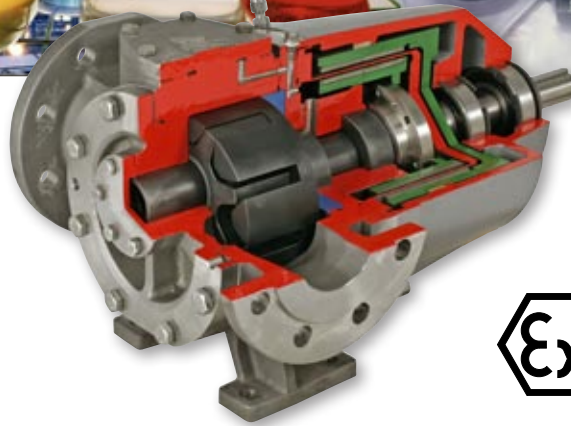

JOHNSON PUMP
AN SPX BRAND

TopGear MAG

Seal-less Internal Gear Pumps



TopGear MAG – *Protecting your future*

TopGear MAG is a range of leak-proof internal gear pumps for low and high viscous liquids which are corrosive, toxic, aggressive or expensive.

Total containment of the liquid inside the pump is achieved using a hermetically sealed can, which isolates the liquid from the surrounding environment. This eliminates the need for shaft seals and the associated wear and leakage that would normally be experienced. The Magnetic Drive pumps are therefore not only environmentally friendly – they also contribute to improved safety in chemical and process plant environments.

Complying amongst others with the “ATEX” (ATmospheres EXplosibles) directive, magnetic drive pumps make an important contribution to health and safety on process plants.

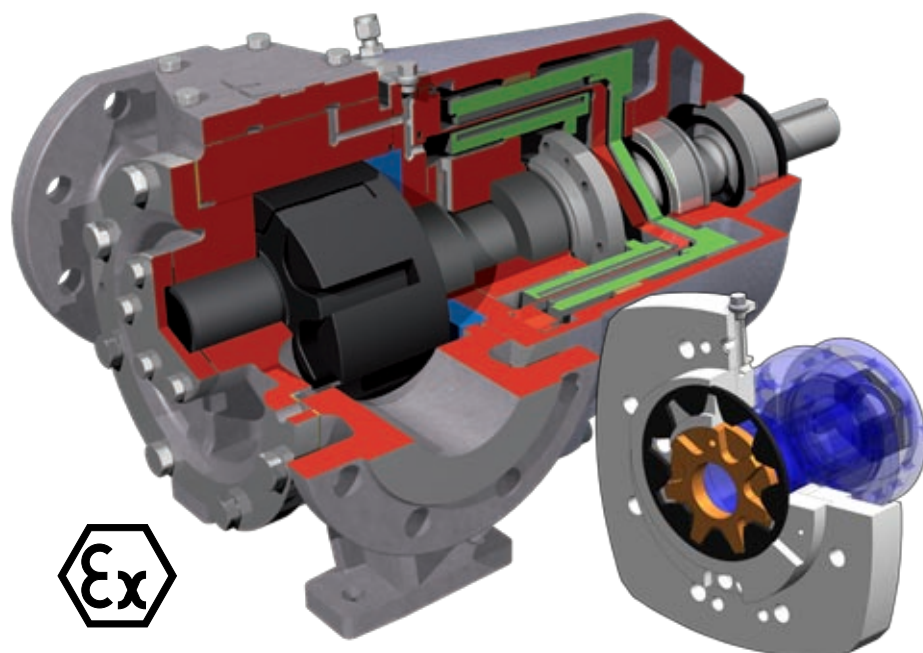

MAG drive - hermetic closed pump system

Ensures clean, safe and leak-free operating environment. Zero leakage of corrosive, toxic, chemical, expensive or vulnerable liquids.

Unique solution for forced circulation and cooling

Patent pending for integrated circulation pump in intermediate cover – guaranteed cooling and lubrication of magnetic coupling and bearings independent of operation pressure and liquid viscosity. Safeguard durable operation for low and high viscous liquids.

Large gap between inner magnet and can

Minimizes friction losses when pumping high viscous media giving low heat generation and long durable operation.

Wet bearings of special SiC

Can handle low viscous media and is extremely wear resistant.

Hermetic can material of Hastelloy C4 between the magnets

Highly chemically resistant and reduces the eddy current losses while increasing efficiency and minimizing temperature. Safeguards durable operation and long life time.

Safety system for bearing failures

Prevents both outer magnetic as inner magnetic rotor from running against the can in case of bearing failure. No risk for leakage and contamination.

Monitoring options

Possible to install sensors to monitor temperature, pressure and vibrations for preventive maintenance actions.

Heating jackets and safety relief valves

Heating and cooling jacket options to safeguard pump in start up and shut down process. Steam or thermal oil options available.

Built on safety relief valves to protect pump and other equipment from over pressure.

Heating jackets and relief valves can be combined.

Back and front pull out

Easy access for inspection and maintenance while pump casing remains installed in the pipe system.

Interchangeability

Complete dimensional interchangeability with TopGear GM and H pumps.

Pump specification

Max capacity: 80 m³/h
 Max diff. pressure: 16 bar
 Max temperature: 260°C

Materials: Cast iron or stainless steel; containment can between the magnets - Hastelloy C4

Bearing options: Silicon Carbide or Carbon

Magnets: Standard SmCo magnets for good corrosion resistance and high temperature possibility max 260°C. NdFeB magnets as option for high torque applications - but at limited temperature max 120°C.

Other options: Heating jackets, Relief valves, Temperature probe PT100, ATEX certification, Pump units

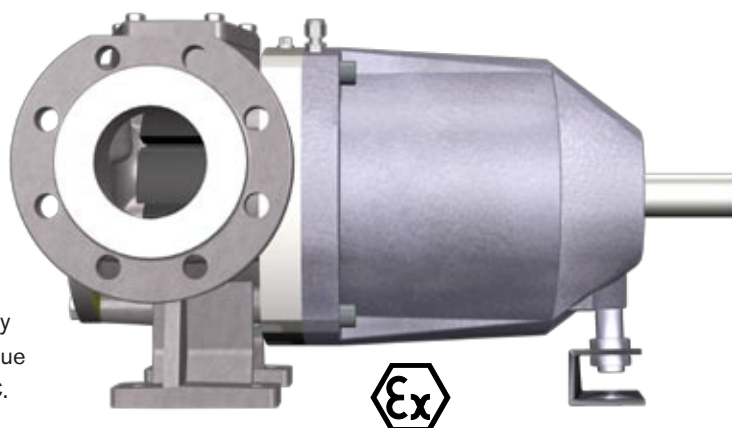

General Performance

Pump size TG MAG	Port diameter (mm)	Max flow (m ³ /h)	Max pressure (bar)	Max speed (rpm)
15-50	50	13	16	1500
23-65	65	20	16	1500
58-80	80	35	16	1050
86-100	100	50	16	960
185-125	125	80	16	750

Operating Principle

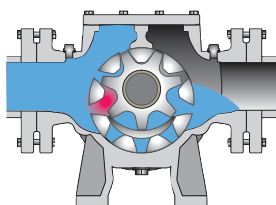

As the rotor and idler unmesh, an underpressure is created and the liquid enters the newly created cavities.

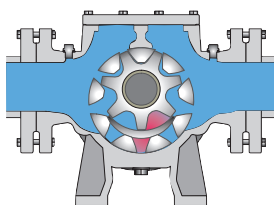

Liquid is transported in sealed pockets to the discharge side.

The walls of the pump casing and the crescent create a seal, that separates suction from discharge side.

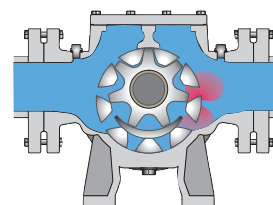

The rotor and idler mesh and liquid is pushed into the discharge line.

Applications

TopGear MAG is the perfect solution for avoiding leakage of liquids which may jeopardize health or environment or for liquids which are just problematic to seal off.

- Crystallizing and hardening liquids
- Toxic and hazardous liquids

Example of liquids:

Phenol, Solvents, Isocyanates, Sodium hydroxide, Epoxy resin, Paint, Glue, Ink, Fuel Additives, Caustic solutions, Sugar solutions, Oils, Bitumen, Alcohols

TopGear MAG provides environmental, human, legal and economical protection - **Protecting your future**

