

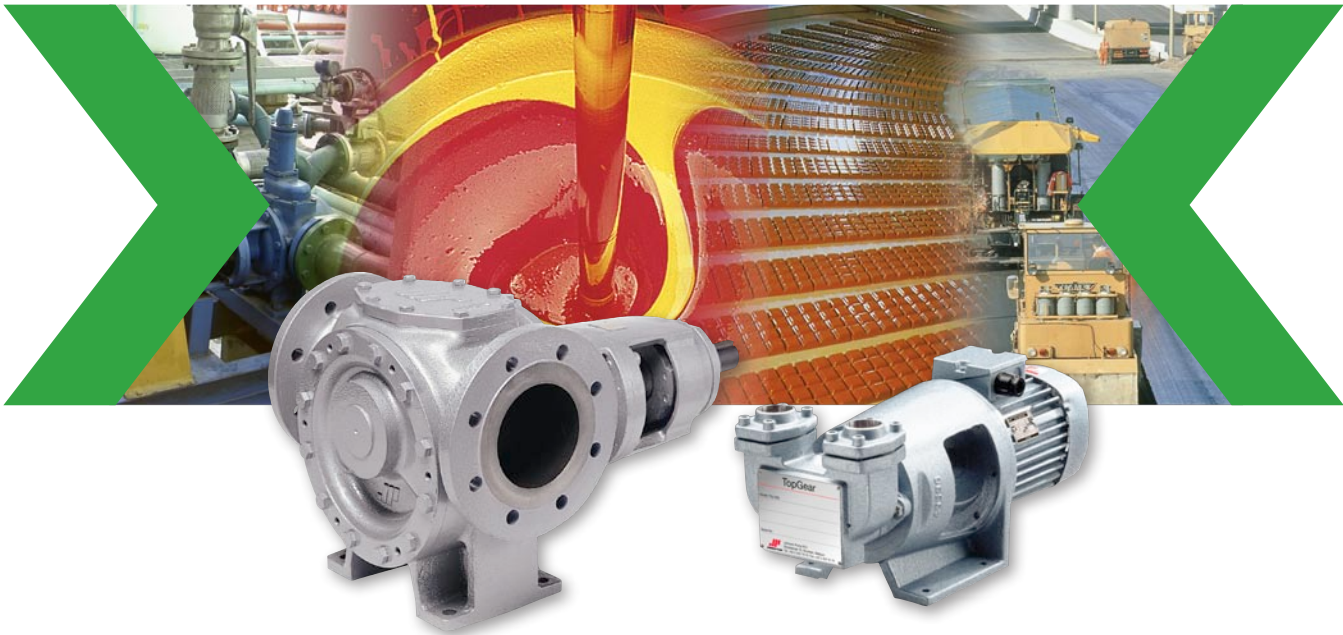

TopGear Internal Gear Pumps



TopGear –

When reliability is the priority

Gear pumps are used in all types of manufacturing industries for the transportation of both thin and thick liquids, from diesel fuels to chocolate. Our heavy duty pumps are designed around high reliability as well as long life.

We make gear pumps that our customers can rely on.

The moment you buy a Johnson Pump brand gear pump from SPX Process Equipment, you will join thousands of industrial customers who rely on our pump technology.

Their main interest is not the pump itself, but smooth, high-quality, uninterrupted production – at a lower total cost.

The Johnson Pump brand represents more than 50 years of experience in developing and manufacturing gear pumps and is one of the leading suppliers in the market.

The wide Johnson Pump brand TopGear series is divided into three ranges :

the L-range : Low viscosity - high efficiency

the G-range : General purpose

the H-range : High demanding applications

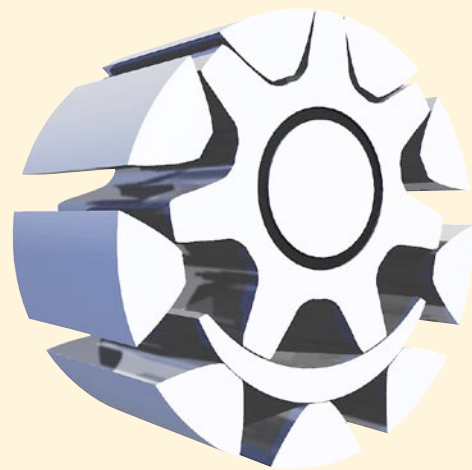

Typical characteristics

- Heavy duty design for long term reliability
- High and low viscous products
- Smooth flow
- Simple design - only two moving parts
- Easy maintenance
- Reduced down time for service
- Wide range of materials
- High efficiency
- Conforms to API 676

TopGear –

Knowledge results in the perfect solution

Technical know-how and customer knowledge are the driving forces for SPX Process Equipment when designing the programme of Johnson Pump brand gear pumps. TopGear pumps are used in various industries and environments, which have thousands of liquids that need to be pumped.

TopGear offers a combination of strong design with small or large clearances, unique gear tooth profile and options such as electrical heating and built-on safety relief valves.

Sometimes the fluids are explosive, sometimes poisonous. They can be free-flowing or extremely viscous. SPX Process Equipment has the experience and knowledge to meet the demands these different characteristics place on the pumps.

Together with our customers we select the right material and choose the right seal options to help you reach the optimal lifetime for the pump in various applications.

- **Petrochemicals**
Pure or filled bitumen, pitch, diesel oil, crude oil, lube oil
- **Chemicals**
Sodium silicate, acids, plastics, mixed chemicals, isocyanates
- **Paint and Ink**
- **Resins and Adhesives**
- **Pulp & Paper**
Acid, soap, lye, black liquor, kaolin, lime, latex, sludge
- **Food**
Chocolate, cacao butter, fillers, sugar, vegetable fats and oils, molasses, animal feeds



Features and Benefits

Improved priming, low NPSHr

- Ports above centerline
- Oversized ports for better efficiency

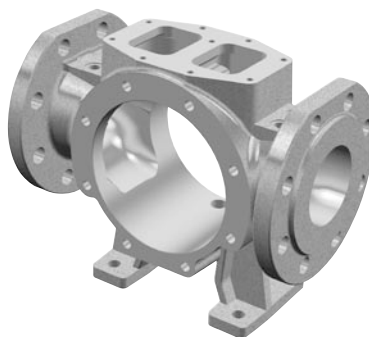

Flange connections options

- ANSI

Improved design for low and high viscous media

- Optimized gear tooth profile
- Smooth flow



H-range/G-range

High efficiency

- Axial rotor locking
- Adjustable clearances
- Balanced hydraulic design

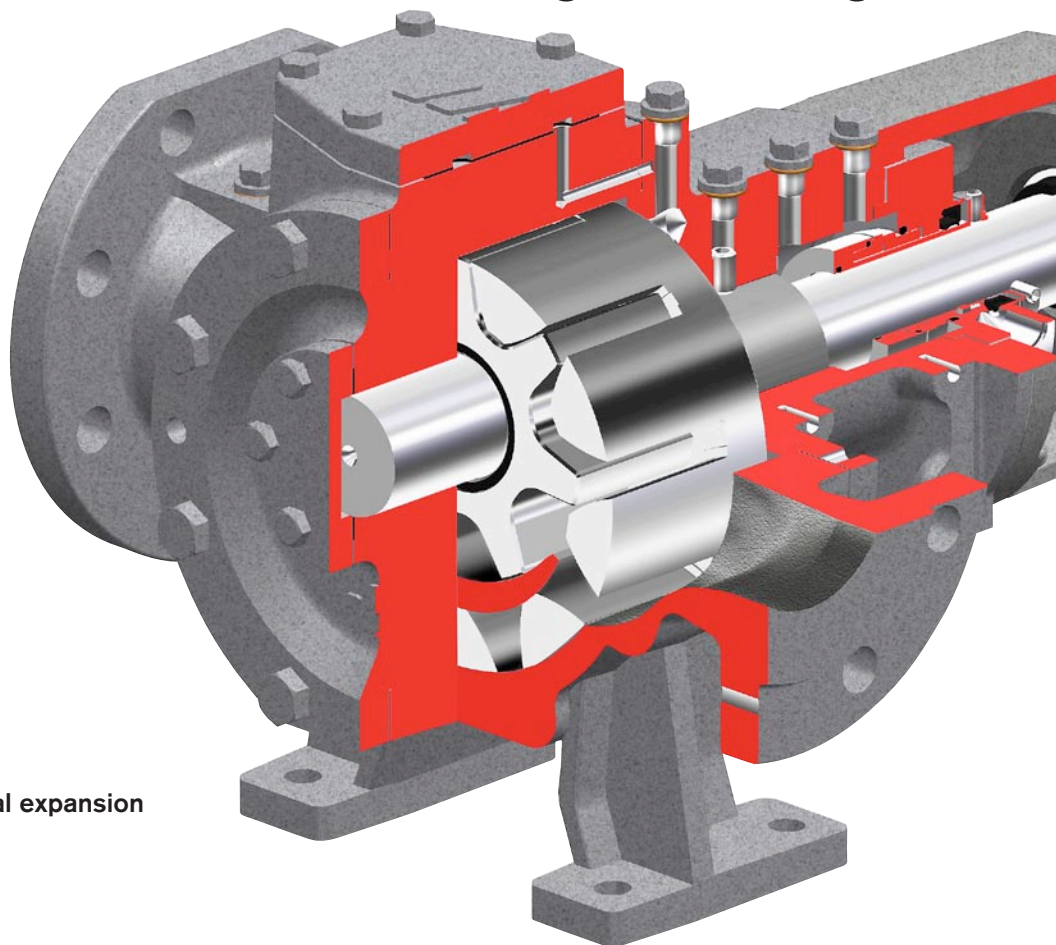
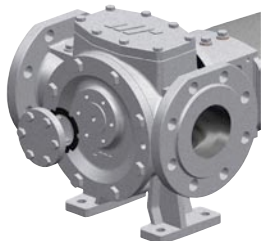

Eliminated leakage during thermal expansion

- Pin cover
- Safety sealed

Less downtime

- Front and back pull-out



Prolonged service life

- Double ball bearing design
- Adjustable axial clearance
- Allows V-belt drive
- Accepts higher axial forces

Several material options

- Shaft seal materials
- Bearing materials
- Hydraulic parts

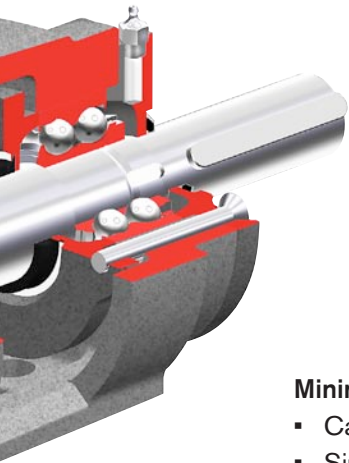

Minimum of maintenance

- Cartridge design
- Simple design

Maximized lifetime

- Compact rotor
- Strong shafts
- Maximized bearing design
- Possibility for selection of hardmetal bearings
- On seals thanks to seal relief channel

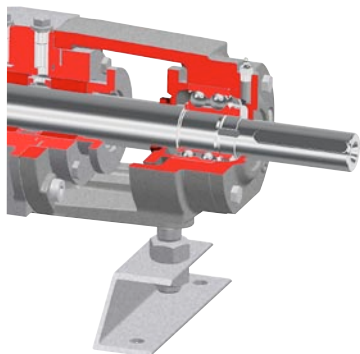

High volumetric efficiency

- Small radial and axial clearances
 - reduced slip
- Optimized rotor/gear shape

Long service life

- Large bearing diameters
- Rotors are machined from solid bar stock material.
- Hardened interior parts

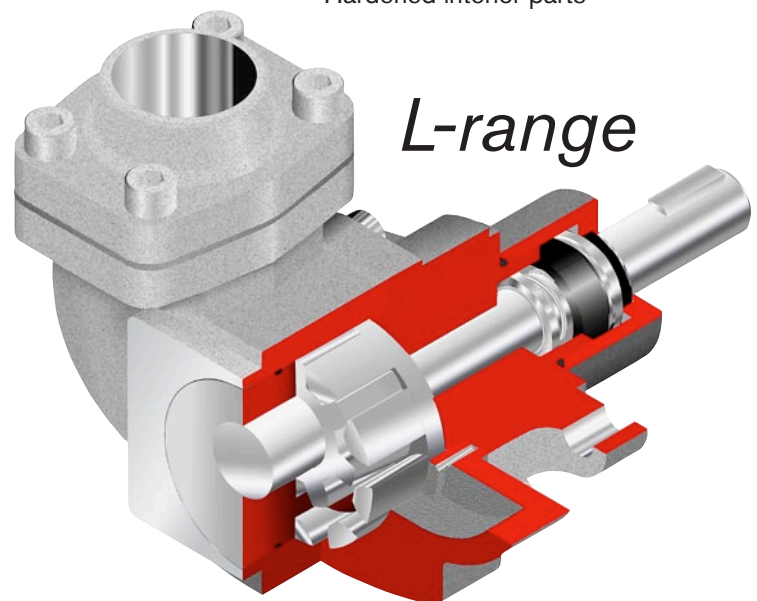

Less down time

- Pumps and motors flanged to pedestals
 - correct alignment between pump and drive shaft
- Compact units easy to assemble

Prolonged seal life

- Pressure relief channel from the seal area back to the suction side

Large vertical ports

- Improved priming capability
- Reduced risk of cavitation

Options

Shaft seal options

Shaft seal options include packed gland, single and double mechanical seals, lip seals and cartridge seals.

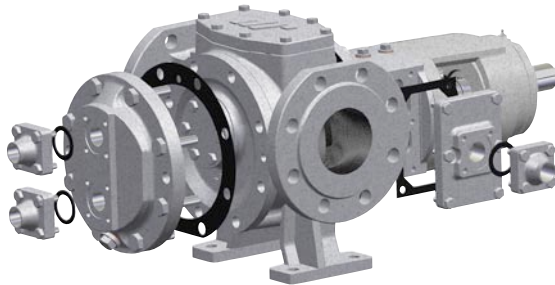
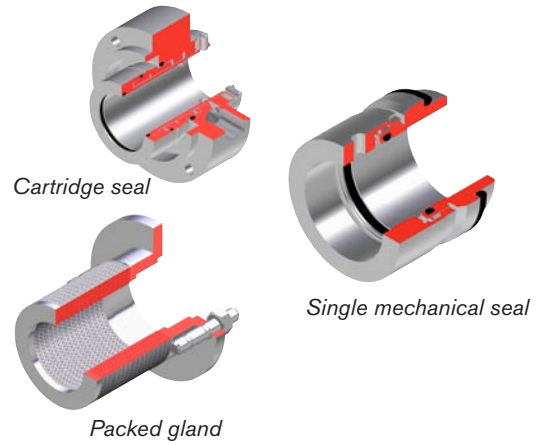

Jackets for pump cover and around the shaft seal

Jacket options

Heating and cooling jackets guarantee the performance of the pump in a start-up or a shut-down procedure. They also provide the pump with the best condition for the seals during operation. Different options : thermal oil, steam or electrical heating.



Single safety relief valve

Safety relief valve options

Built-on safety relief valves protect the pump, as well as other equipment in the system, from over pressure.

When the pump is used bi-directionally, a double safety relief valve is provided.



Double safety relief valve

Operating principle

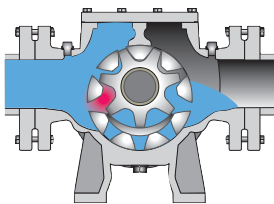

As the rotor and idler unmesh, an underpressure is created and the liquid enters the newly created cavities.

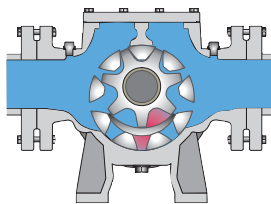

Liquid is transported in sealed pockets to the discharge side.

The walls of the pump casing and the crescent create a seal, that separates suction from discharge side.

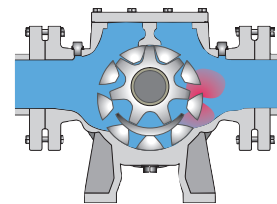

The rotor and idler mesh and liquid is pushed into the discharge line.

Technical data

	TG L	TG G			TG H
		TG GS	TG GP	TG GM	
Casing	Cast Iron	Cast Iron			Stainless Steel Cast Steel Ductile Iron
Idler & rotor	Steel	Iron Stainless Steel			Nodular Iron Stainless Steel
Max Capacity (GPM)	35	350	570	1,100	570
Max differential pressure (psi)	440	150	230		230
Max temperature (°F)	480	390	570		570
Max viscosity (Cps.)	60,000	5,000	80,000		80,000

General performance

