



**JOHNSON PUMP**  
 AN SPX BRAND



# TopFilter TFOV

## Single filter 20 mm (3/4")–150 mm (6")

TopFilter TFOV provides a cost-effective method of protecting pipeline equipment, cleaning liquids or salvaging valuable solids. Incorporated are a number of special features and optional extras. The filter is of cast construction and is supplied with one high quality stainless steel cylindrical basket. It is used in liquid handling installations where the flow can be shut off for short periods to allow the removal of the basket for cleaning.

### Main Features

- High quality 316 grade stainless steel basket with large filtration areas resulting in low pressure drops.
- Compact design for space saving.
- Working pressures up to 50 bar (A300 Series).
- Quick release filter covers and knobs for easy maintenance.

### Options

- Range of extras allowing filter to be customised.
- Available in cast iron, cast steel, gunmetal (bronze) or stainless steel.
- Visual/Electrical differential pressure indicators are available.
- Magnetic columns (pre-magnetic filtration).

### Specifications

	TFOV	TFOV/S	TFOV/GM	TFOV/SS	TFOV/S & SS A300 Series
<b>Body &amp; cover material</b>	Cast Iron EN1561/ EN-JL 1030	Cast steel EN 10213-2/1.0625	Gunmetal (Bronze) BS 1400 Grade LG4C	Stainless Steel BS 1504 316 C16	Cast steel EN10213-2/1.0625 (S) Stainless steel BS1504 316 C16 (SS)
<b>Maximum working pressure</b>	17 bar at 50°C	22 bar at 50°C	22 bar at 50°C *)	22 bar at 50°C	50 bar at 50°C (S) 48 bar at 50°C (SS)
<b>Baskets</b>	Stainless Steel — Basket & Mesh Lining BS1449 Grade 316 S31				
<b>Drain plug</b>	Brass	Stainless Steel	Gunmetal (Bronze)	Stainless Steel	Stainless Steel
<b>Vent</b>	Stainless Steel	Stainless Steel	Phosphor Bronze	Stainless Steel	Stainless Steel
<b>Standard seals</b>	Viton® (-20°C to +200°C)				
<b>Body colour</b>	Grey	Silver	Natural	Natural	Silver (S) /Natural (SS)

\*) Gunmetal (bronze) DN 20, 25 & 40 filters are rated at 13.8 bar at 50°C  
 Viton is a registered trademark of DuPont Performance Elastomers.

DN 200 & DN 250 filters are rated at 13.8 bar at 50°C (Standard Range).

#### Please note

- 1 These specifications refer to standard products only. Other materials for bodies (e.g. monel, hastelloy) and seals (e.g. Nitrile, EP, PTFE) are available on request.
- 2 Higher pressures are available up to 50 bar.
- 3 Working pressure is stated at 50°C. To verify suitability of this equipment above this temperature or below 0°C, please contact us for more information.
- 4 Whilst alternative seal materials e.g. Nitrile, EP, PTFE are available and can be used to offer a wide range of chemical compatibility and working temperatures up to 260°C, it is recommended that such applications are again discussed with us.



### Equivalent Material Specifications

	Cast Iron	Cast Steel	Gunmetal (Bronze)	Stainless Steel
European Standard	BS EN1561/EN-JL 1030	BS EN10213-2/1.0625	BS 1400 Grade LG4C	BS 1504 316 C16
American Standard	ASTM A48/76 Class 35	ASTM A216 Grade WCB	-	ASTM A351 CR8M

### Threaded BSP or NPT (sizes in mm)

A Pipe Size	B	C	D	E	F	G	H	J	K	L	Element Area	Weight (Cast Iron)
20 (3/4")	159	108	103	220	73	105	64	50	86	1/2" BSP	184 cm <sup>2</sup>	5 kg
25 (1")	159	108	103	220	73	105	64	50	86	1/2" BSP	184 cm <sup>2</sup>	5 kg
32 (1 1/4")	174	108	129	306	73	145	90	50	122	1/2" BSP	268 cm <sup>2</sup>	7 kg
40 (1 1/2")	174	108	129	306	73	145	90	50	122	1/2" BSP	268 cm <sup>2</sup>	7 kg
50 (2")	270	156	165	351	112	156	112	76	131	1/2" BSP	484 cm <sup>2</sup>	19 kg
65 (2 1/2")	270	156	165	351	112	156	112	76	131	1/2" BSP	484 cm <sup>2</sup>	19 kg

### Flanged BS10, BS4504, ANSI or DIN (sizes in mm)

A Dia. Bore	B	C	D	E	F	G	H	J	K	L	M*	N*	Element Area	Weight (Cast Iron)
25 (1")	194	108	103	220	73	105	64	50	86	1/2" BSP	124	16	184 cm <sup>2</sup>	8 kg
40 (1 1/2")	210	108	129	306	73	145	90	50	122	1/2" BSP	156	18	268 cm <sup>2</sup>	12 kg
50 (2")	310	156	165	351	112	156	112	76	131	1/2" BSP	165	20	484 cm <sup>2</sup>	24 kg
65 (2 1/2")	310	156	165	351	112	156	112	76	131	1/2" BSP	191	22	484 cm <sup>2</sup>	25 kg
80 (3")	343	175	198	451	132	210	140	76	186	1/2" BSP	210	22/24	718 cm <sup>2</sup>	42 kg
100 (4")	356	175	234	575	132	265	175	76	241	1/2" BSP	229/254	24	964 cm <sup>2</sup>	45 kg
150 (6")	480	-	296	728	160	361	218	-	330	1/2" BSP	318	26	1835 cm <sup>2</sup>	107 kg

\* Dimensions left of the oblique are for cast iron filters. Dimensions right of the oblique are for Steel, Stainless Steel and Bronze.

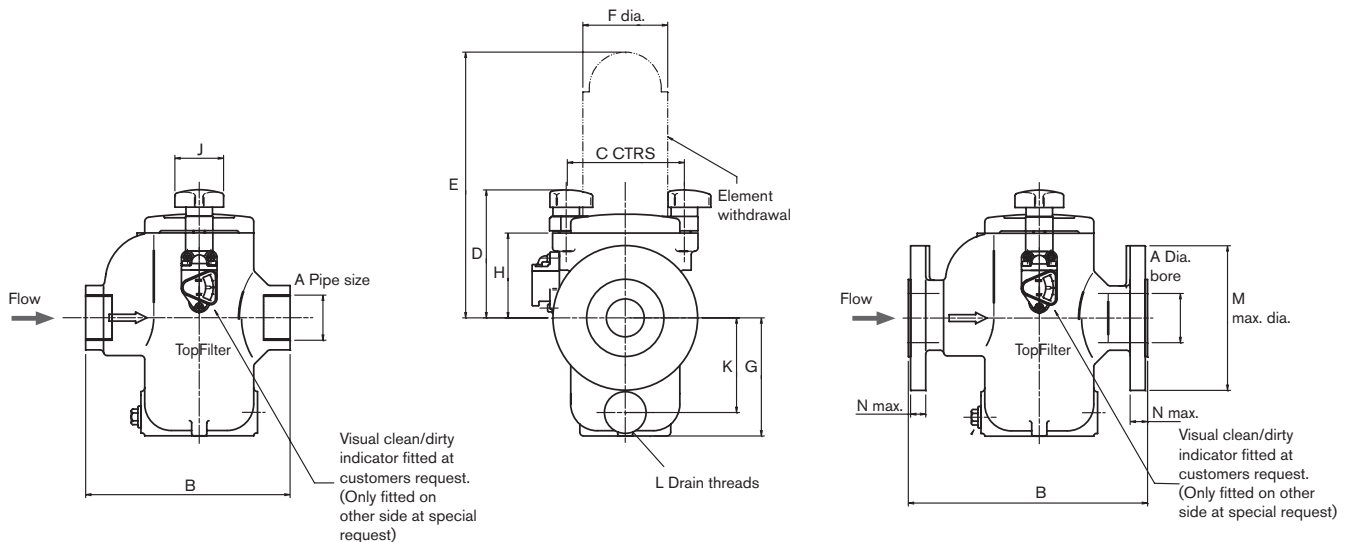

**SPX**<sup>®</sup>  
 WHERE IDEAS MEET INDUSTRY

Your local contact:

SPX Process Equipment BE N.V.  
 Evenbroekveld 2-6, BE-9420 Erpe-Mere, BELGIUM  
 Phone: +32 (0)53 60 27 15 Fax: +32 (0)53 60 27 01  
 E-mail: [jp-industry.be@processequipment.spix.com](mailto:jp-industry.be@processequipment.spix.com)

For more information about our worldwide locations, approvals, certifications, and local representatives, please visit [www.spixpe.com](http://www.spixpe.com).  
 SPX Corporation reserves the right to incorporate our latest design and material changes without notice or obligation. Design features, materials of construction and dimensional data, as described in this bulletin, are provided for your information only and should not be relied upon unless confirmed in writing.