

MCHZ, MCHZS

Horizontal high pressure self-priming pump

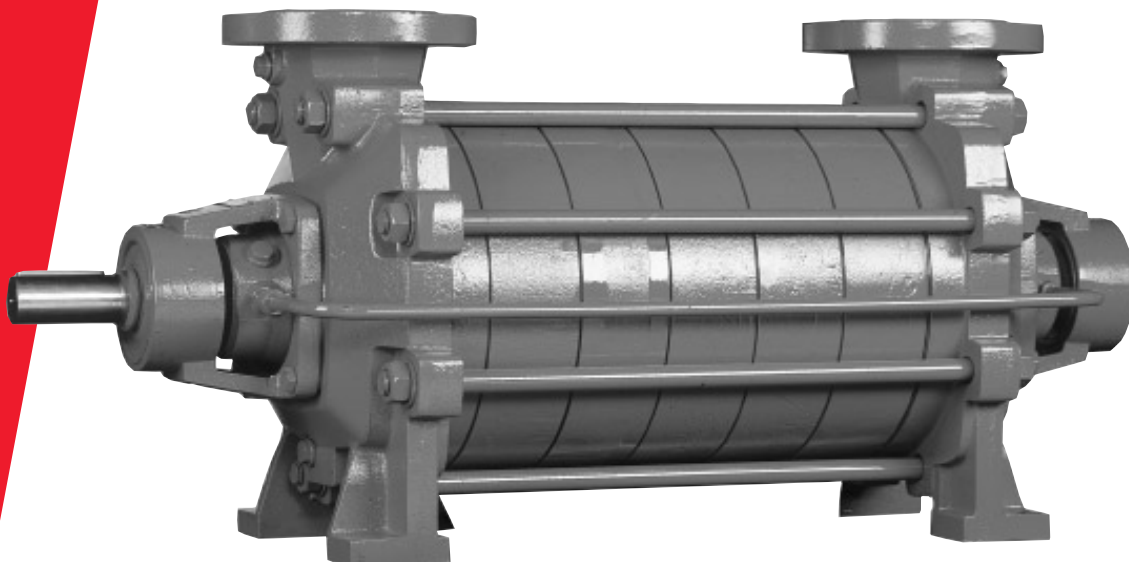

System characteristics

The MCHZ family, a range of horizontal high pressure self-priming pumps, has a high interchangeability in parts to other Johnson pumps, like the MCV or MCH. There are six different sizes, each built up with one or more stages.

The MCHZ family is self-priming by means of a built-in vacuum pump allowing handling of fluids with dissolved air (gas) or exclusively air during the suction/starting period. The integrated vacuum pump operates on the liquid ring principle.

Applications

The MCHZ pump family is suitable for handling clean or slightly contaminated liquids for instance well water, hot water, various coolants, condensed water, brine lye, sea water, petrol, kerosene, and petroleum.

For e.g. booster installations, hot water circulating systems, airconditioning systems, cooling for stationery and marine installations, industry, waterworks, agriculture and horticulture, spraying installations and ship-building.

Pump specifics

- The built-in vacuum pump will drive out any dissolved air (gas) during normal operation
- All types of the MCHZ family are fitted with closed impellers
- Suitable for a wide span of duties
- High interchangeability in spare parts between different sizes, thus limiting spare parts stock levels

Technical data

Type MCHZ:	Stuffing box packing Temperature -15°C – +105°C
Type MCHZS:	Mechanical seal Temperature -20°C – +120°C
Maximum capacity:	100 m ³ /h
Maximum delivery head:	340 m
Maximum operating pressure:	40 - 3 x inlet pressure bar (4000 - 3 x inlet pressure kPa) <i>depending on pump size/ materials</i>
Maximum allowable inlet pressure:	10 bar (1000 kPa)

Materials

Casing parts	Cast iron	
Impeller	Cast iron	Bronze
Pump shaft	Steel alloy	

Performance data

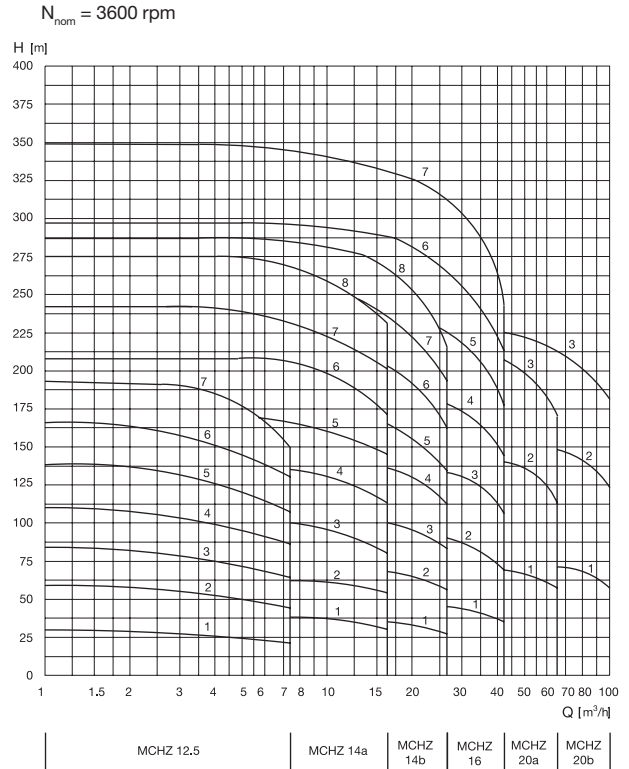
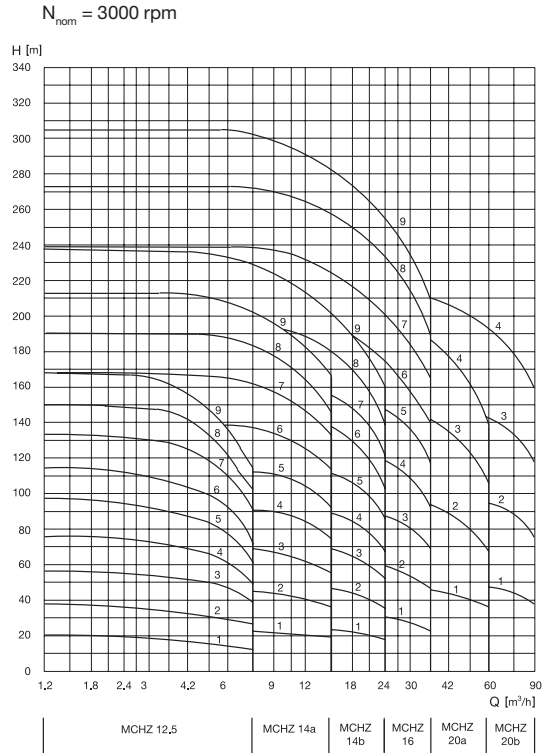

Dimensions

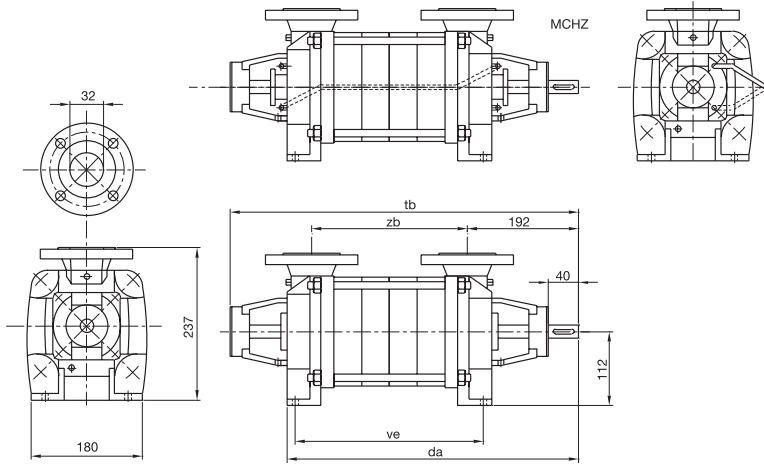

MCHZ - MCHZS	da	tb	ve	zb
12,5 x 1	405	507	227	169
12,5 x 2	450	552	272	214
12,5 x 3	495	597	317	259
12,5 x 4	540	642	362	304
12,5 x 5	585	687	407	349
12,5 x 6	630	732	452	394
12,5 x 7	675	777	497	439
12,5 x 8	720	822	542	484
12,5 x 9	765	867	587	529
	da	da*	tb	tb*
14 a,b x 1	425		527	237
14 a,b x 2	475		577	287
14 a,b x 3	525		627	337
14 a,b x 4	575	621	677	387
14 a,b x 5	626	671	727	437
14 a,b x 6	675	721	777	487
14 a,b x 7		771		537
14 a,b x 8		821		587
14 a,b x 9		871		637
16 x 1 - 6,5	495		624	267
16 x 2 - 6,5	555		684	327
16 x 3 - 6,5	615		744	387
16 x 4 - 6,5	675		804	447
16 x 5 - 6,5	735		864	507
16 x 6 - 6,5	795		924	567
16 x 7 - 6,5	955		984	627
16 x 8 - 6,5	915		1044	687
16 x 9 - 6,5	975		1104	747
20 a,b x 1	600		727	332
20 a,b x 2	675		802	407
20 a,b x 3	750		877	482
20 a,b x 4	825		952	557

* = Pump with improved bearings



Johnson Pump B.V.