



JOHNSON PUMP
AN SPX BRAND

Instruction Manual

KGE

Self-priming centrifugal pump



Read and understand this manual prior to operating or servicing this product.

KGE/EN (0909) 6.0

SPX®

EC Declaration of conformity

(Directive 98/37/EC, appendix II-A)

Manufacturer

SPX Process Equipment NL B.V.
Dr. A.F. Philipsweg 51, 9403 AD Assen
P.O. Box 9, 9400 AA Assen
The Netherlands

hereby declares that the pump, in case it is delivered as an assembly with drive (last position of serial number = A), is in conformity with the provisions of Directive 98/37/EC (as altered most recently) and the following directives and standards:

- EC directive 73/23/EEC, "Electric equipment for use within certain voltage limits"
- Standards EN 292 part 1 & 2, EN 809

The pump to which this declaration refers may only be put into operation after it has been installed in the way prescribed by the manufacturer, and, as the case may be, after the complete system of which this pump forms part, has been made to fulfil the requirements of Directive 98/37/EC (as altered most recently).

Manufacturer's declaration

(Directive 98/37/EC, appendix II-B)

Manufacturer

SPX Process Equipment NL B.V.
Dr. A.F. Philipsweg 51, 9403 AD Assen
P.O. Box 9, 9400 AA Assen
The Netherlands

hereby declares that the pump, in case it is delivered without drive (last position of serial number = B) is in conformity with the following standards:

- EN 292 parts 1 & 2, EN 809

and that this pump is meant to be incorporated in or combined with another machine (electric motor, combustion engine) and may only be put into use after the complete machine of which the pump under consideration forms part has been made and declared to comply with that directive.

Assen, May 1 st 2008



Gerwin Schaafsma
Managing Director

Contents

1.0	Introduction	5
1.1	Safety (general)	5
1.1.1	Signs on the pump	5
1.1.2	This instruction manual is meant for :	5
1.1.3	Safety instructions relevant for operation	6
1.1.4	Safety instructions relevant for maintenance, inspection and assembly work	6
1.2	Guarantee	6
1.2.1	Copyright	6
1.3	SPX Process Equipment service	7
1.4	Symbols used	7
1.5	Check delivery	7
1.6	Instructions for transport and handling	7
2.0	General information	8
2.1	Field of application	8
2.2	Inadvisable use	8
2.3	Type designation	8
2.4	Materials	9
2.5	Selfpriming action	9
3.0	Installation and preparation start-up	10
3.1	General	10
3.2	Location	10
3.3	Main piping (suction / discharge)	10
3.3.1	Forces and torques on the flanges	10
3.4	Piping accessories	11
3.5	Foundation / base plate	12
3.5.1	Pump units assembled on baseplate	12
3.5.2	Alignment pump unit	12
3.6	Preparations start-up	13
3.7	Drive	13
3.7.1	Connection of electric motors	13
3.7.2	Types	14
3.8	Combustion engines	15
3.9	Direction of rotation	15
4.0	Start-up	16
4.1	Temperature	16
4.2	Noise emission	16
4.3	System pressure	16
4.4	Shut-down	16
4.5	Trouble shooting	17
4.5.1	Fault finding chart	17
4.5.2	Re-use	18
4.6	Scrapping of the pump	18

5.0	Maintenance _____	19
5.1	Precautionary measures _____	19
5.2	Daily _____	19
5.3	Periodic inspection _____	19
5.4	Flushing _____	19
5.5	Ball Bearings _____	20
5.6	Electrical installation _____	20
5.7	The oil chamber _____	20
5.8	Mechanical seal _____	20
5.9	Lip seal _____	21
5.10	Impeller _____	21
6.0	Assembly and disassembly _____	22
6.1	General _____	22
6.2	Replacing the impeller _____	22
6.2.1	Disassembly impeller _____	22
6.2.2	Impeller assembly _____	23
6.3	Replacement of mechanical seal _____	23
6.3.1	Disassembly of mechanical seal _____	23
6.3.2	Assembly of single mechanical seal _____	23
6.4	Replacement of the bearings _____	24
6.4.1	Disassembly of the ball bearings _____	24
6.4.2	Assembly of the ball bearings _____	24
6.5	Motor replacement (KGEF) _____	24
6.5.1	Motor disassembly _____	24
6.5.2	Motor assembly _____	24
6.6	Waste handling/material recycling _____	24
7.0	Technical specifications _____	25
7.1	Technical data _____	25
7.2	Dimensions KGE Pump with bare shaft end _____	26
7.3	Dimensions KGEF Pump with flanged motor _____	27
7.4	Dimensions KGE pump with motor (assembly A6) _____	28
7.5	Survey curve ($n = 2900 \text{ min}^{-1}$) _____	29
7.6	Parts list and sectional drawing KGE① Bearing bracket 00 KGE11-3 / KGE11-4 _____	30
7.7	Parts list and sectional drawing KGE② Bearing bracket 0 KGE12(b)-5 / KGE12-6 _____	31
7.8	Parts list and sectional drawing KGE②+, Bearing bracket 0+ KGE14-8 _____	32
7.9	Parts list and sectional drawing KGE② Bearing bracket 0 KGE16-3 _____	33
7.10	Parts list and sectional drawing KGE②+, Bearing bracket 0+ KGE15 - 6 / KGE16 - 6 _____	34
7.11	Parts list and sectional drawing KGE③ Bearing bracket 1 KGE18-4 / KGE20b-5 _____	35
7.12	Parts list and sectional drawing KGE④ Bearing bracket 2 KGE22-6 _____	36
7.13	Parts list and sectional drawing KGEF Bearing bracket 00,0 and 0+ (①②②+) _____	37
7.14	Parts list and sectional drawing KGEF③④ Bearing bracket 1 and 2 KGEF18-4 / KGEF20b-5 _____	38

1.0 Introduction

- The data published in these operating instructions have been based on the most recent information. They are provided subject to alterations.
- We reserve the right to change the design and/or construction of our products at any time without being obliged to adapt earlier supplies accordingly.
- These operating instructions (and annex if any) contain useful and important information allowing your pump to be properly operated and maintained. They also contain important instructions for preventing possible accidents and serious damage prior to commissioning and during operation of the installation, thus ensuring as safe and trouble free an operation of your installation as possible. Carefully read the instructions prior to putting the pump into operation, familiarize yourself with the functioning and operation of your pump and strictly adhere to the instructions given. In this respect we would emphasize the importance of training in the correct handling of the installation. It is essential that these operating instructions are kept in a fixed place in the vicinity of the installation.

Should you have any further questions or wish to receive additional explanation regarding specific matters concerning your pump (adjusting, assembly/disassembly ...) which are not included in this instruction manual, please do not hesitate to contact our technical or service departments.

1.1 Safety (general)

1.1.1 Signs on the pump

It is imperative that signs affixed to the pump, e.g. arrow indicating the direction of rotation or symbols indicating fluid connections be observed and kept legible.

1.1.2 This instruction manual is meant for:

- Personnel that should read and understand this instruction manual completely: The personnel responsible for operation, maintenance, inspection and assembly. These people must be adequately qualified. Scope of responsibility and supervision of the personnel must be exactly defined by the plant operator. Moreover, the plant operator is to make sure that the contents of the operating manual are fully understood by the personnel. **If the staff does not have the necessary knowledge, they must be trained and instructed, which may be performed by the machine manufacturer or supplier on behalf of the plant operator.**
- Your technical and servicing personnel which is provided with the required information in chapter Technical Specifications 7.0. Sectional drawings with part lists are intended for those who are responsible for spare parts ordering.

1.1.3 Safety instructions relevant for operation

- The limit values specified in the data sheet must under no circumstances be exceeded.
- If hot or cold machine components involve hazards, they must be guarded against accidental contact.
- Guards for moving parts (e.g. coupling) must not be removed from the machine while in operation.
- Any leakage of hazardous (e.g. explosive, toxic, hot) fluids (e.g. from the shaft seal) must be drained away so as to prevent any risk to persons or the environment. Statutory regulations are to be complied with.
- Hazards resulting from electricity are to be prevented (see for example, the VDE Specifications and the bye-laws of the local power supply utilities).

1.1.4 Safety instructions relevant for maintenance, inspection and assembly work

- Any work on the machine shall only be performed when it is at a standstill, it being imperative that the procedure for shutting down the machine described in this manual be followed.
- Pumps and pump units which convey hazardous media must be decontaminated.
- Using spare parts and accessories authorised by the manufacturer is in the interest of safety. Use of other parts may exempt the manufacturer from any liability.
- Any modification may be made to the machine only after consultation with the manufacturer.
- The reliability of the machine delivered will only be guaranteed if it is used in the manner intended, in accordance with instructions in this manual.
- On completion of work all safety and protective facilities must be reinstalled and made operative again.
- Prior to restarting the machine, the instructions listed under “Initial Commissioning” are to be observed.

1.2 Guarantee

We point out that any guarantee issued for your installation will become null and void and that you shall indemnify us against any product liability claims filed by third parties if:

- The servicing and maintenance jobs have not been performed strictly in accordance with the instructions, repairs have not been carried out by our personnel or carried out without our prior written consent;
- The installation has been changed without our prior written consent;
- Non-original SPX Process Equipment parts or lubricants other than those specified have been used;
- The installation has been used inexpertly, incorrectly, carelessly or not in line with its nature and/or destination.

All parts subject to wear are excluded from any guarantee claim.

The General Terms of Delivery already in your possession are also applicable.

1.2.1 Copyright

Any technical and technological information contained in these operating instructions, as well as any drawings and technical specifications made available by us remain our property and shall not to be used (other than for the operation of this installation), copied, multiplied, handed over or communicated to third parties without our prior written consent.

1.3 SPX Process Equipment service

Should you have any further questions or wish to receive additional explanation regarding specific matters concerning your pump (adjusting, assembly/disassembly etc.), please do not hesitate to contact us.

1.4 Symbols used

While following instructions you may notice some of them are only applicable for certain constructions. That is why following division is maintained :

pump size	construction	symbol
11-3	00	①
11-4		
16-3	0	②
12b-5		
12-5		
12-6		
15-6	0+	②+
16-6		
14-8		
18-4	1	③
20b-5		
22-6	2	④

Remark: Construction 0 and 0+ have different bearings

1.5 Check delivery

Check immediately upon receipt for any damage, and that the goods are conform to the delivery note. Have the carrier report (in writing) any damage, or missing items. Each pump has a serial number. Please state this number on all documents and letters.

In case the pump is not immediately put into service, take the necessary measures to prevent it from seizing up (e.g. periodically rotate the pump shaft several times).

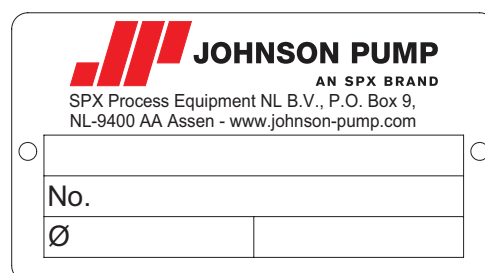

Fig 1 - Name plate with serial number

1.6 Instructions for transport and handling

Pumps or pump units are often too heavy for manual repositioning.

- Consult technical specifications of your pump and do use the proper transport and lift tools.
- Leave movement of pumps to authorised personnel. Do not operate or walk under heavy loads.

2.4 Materials

Part	Material
Pump casing	cast iron
Impeller	cast iron, bronze or polypropylene
Mechanical seal cover	cast iron
Pump shaft	17% chrome steel
Mechanical seal material	carbon / ceramic
Elastomers	Buna for bearing bracket assembly 00,0,0+
	Viton for mechanical seal with bearing bracket assemblies 1-2

2.5 Selfpriming action

KGE pumps are of the selfpriming type. The selfpriming action relies on the principle of injection. The pump has to be filled with liquid once. When it has been switched on, the air (or gas) is evacuated from the suction line. The aspirated air is mixed with the liquid contained in the impeller.

Through the centrifugal force, the liquid / air mixture from the volute flows to the upper half of the pump casing. In the generously sized pump casing the liquid can be de-aerated. The air escapes to the discharge line. The de-aerated liquid has a higher specific gravity than the liquid with air contained the volute. This causes the liquid to return to the volute (with some pumps the liquid flows back through the impeller inlet), where it is aerated and then de-aerated again in the upper part of the pump casing. The air is evacuated from the suction line and the liquid level in this piping rises.

Once all air has been evacuated, the pump starts working as a normal centrifugal pump. A precondition for good functioning is that it should be possible for the aspirated air to escape without back pressure in the discharge line (open valves!).

The pump has a non-return valve, so the suction and discharge lines can not be siphoned empty, when the pump has been stopped. The remaining liquid in the pump is always sufficient for the next suction phase.

- A: water /air separation
- B: pump casing
- C: volute
- D: impeller
- E: back flow opening

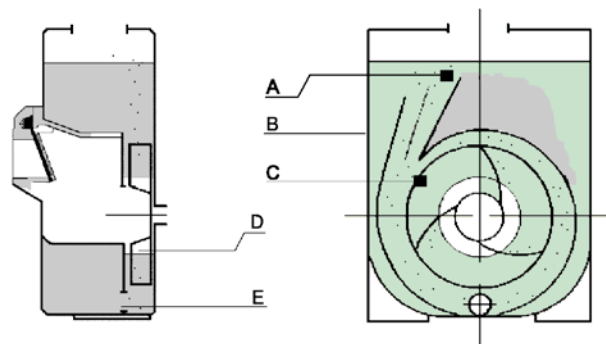

Fig 2

3.0 Installation and preparation start-up

The instructions for installation contain important and helpful information for the proper functioning and maintenance of your equipment. It is absolutely vital that you go through this publication attentively, to acquaint yourself with the operation and to follow the recommendations. The instructions for installation contain also hints to avoid accidents and severe damage before commissioning and during operation, and to assure safe and trouble free performance of the pump. (See also general information)

3.1 General

- Leave installation and start-up to authorised personnel.
- Make sure rotating parts are well covered and that the pump is isolated, and cannot be started whilst jobs are carried out on the pump.
- Make sure that a guard offers protection against rotating parts when running the pump.
- Mount any parts that may have been supplied separately.

3.2 Location

- Locate the pump / pumpunit close to the liquid source. The better the suction conditions, the better the performance of the pump.
- Sufficient room should be left around the pump / pump unit to allow proper inspection, pump isolation and maintenance. (refer to dimensions in Technical Specifications 7.0).
- It is imperative that the operating device of pump and/or pump unit is always (also during operation) accessible.
- The area in which the pump unit is to be placed should be adequately ventilated. A too high ambient temperature and air humidity, as well as a dusty environment may have a negative effect on the functioning of the pump.
- If there is any risk of freezing, switch off the pump, drain it and preferably flush or fill it with oil, if permitted.

3.3 Main piping (suction / discharge)

- Select the suction line diameter as a function of its length. It must not be smaller than the pump suction connection.
- The suction and discharge lines should have a snug fit and remain stress free, also during operation.

3.3.1 Forces and torques on the flanges

The working forces and torques on the flanges cause deformation of the pump unit. Excessive forces and torques can cause mechanical damage to the pump. These forces and torques manifest themselves in a displacement of the ends of the pump and motor shafts. As a point of departure for determining the permitted forces and torques on the flanges, the following maximum values for the radial displacement of the end of the pump shaft can be applied :

bearing bracket 00 ①	0.15 mm
0 / 0+ ②	0.20 mm
1 ③	0.20 mm
2 ④	0.20 mm

For the determination of the forces, the weight of the pipes and the liquid must be taken into account. A distinction must be made between a pump unit which has its baseplate set in concrete and one that does not.

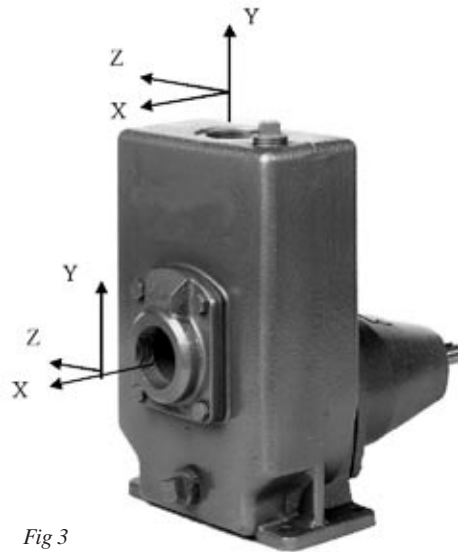

Fig 3

Index v : in the vertical direction (the y-axis)
 Index h : in the horizontal direction (x- and z-axes)
 M : torque in the surface (plane) of the flange
 Fv : force in the vertical direction
 Fh : force in the horizontal direction

Permitted forces and torques on the flanges (based on ISO5199)

KGE	bracket	Pump or baseplate not set in concrete			Pump or baseplate set in concrete		
		Fv _{max.} [N]	Fh _{max.} [N]	M _{max.} [Nm]	Fv _{max.} [N]	Fh _{max.} [N]	M _{max.} [Nm]
11-3	00	1060	950	175	1900	1500	450
11-4	00	1060	950	150	1900	1500	425
16-3	0	1230	1050	250	2150	1800	625
12b-5	0	1230	1050	250	2150	1800	625
12-5	0	1230	1050	250	2150	1800	625
12-6	0	1570	1250	475	2750	2500	1200
15-6	0+	1270	1050	325	2350	2100	850
16-6	0+	1270	1050	325	2350	2100	850
14-8	0+	1400	1050	400	2550	2300	1000

3.4 Piping accessories

- A foot valve in the suction line is not required for this selfpriming pump.
- Foreign particles can damage the pump. Avoid the entry of big or hard particles by installing a strainer.

3.5 Foundation / base plate

- Ensure to a hard and level foundation.
- To anchor the base plate, proceed as follows :

3.5.1 Pump units assembled on baseplate

The following applies when the units are assembled on the baseplate:

- A coupling guard protecting from rotating parts must always be installed.
- The pump and motor shafts of complete units have been accurately factory-aligned. After arrangement of the pump unit, check the pump and motor shaft alignment and, if necessary, realign as follows :
The KGEF close coupled pump can be fastened directly on a foundation; realignment is not necessary.

3.5.2 Alignment pump unit

Place a ruler (A) on the couplings; the ruler should touch both half couplings over the entire length (see figure).

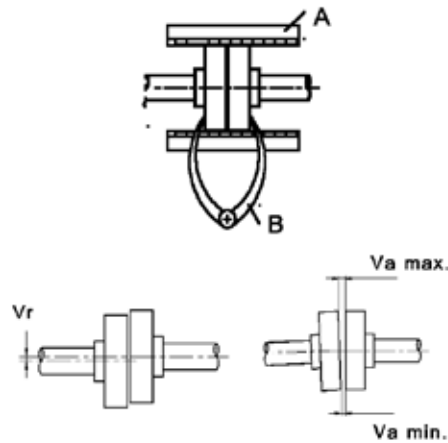

Fig 4

Do the same check, but now on either coupling side, near the shaft. For safety sake, repeat the check, using an outside caliper (B) at 2 diametrically opposed points on the half coupling side faces.

Tolerances for aligning coupling [mm]

Outer Ø coupling	Va min.	Va max.	Va max. - Vamin.	Vr.
70 - 80	2	4	0.13	0.13
81 - 95	2	4	0.15	0.15
96 - 110	2	4	0.18	0.18
111 - 130	2	4	0.21	0.21
131 - 140	2	4	0.24	0.24
141 - 160	2	6	0.27	0.27

3.6 Preparations start-up

Take the following precautions:

- Before commissioning the pump, remove any preservatives and flush the pump with hot water.
- Check whether the seal chamber is filled with oil. If not, fill with lubricant.
- ***Never allow the seal to run dry !***
- Check whether the pump shaft turns freely. Do this by turning the shaft end a few times by hand.
- Fill the pump with water or the liquid to be handled through the filling plug on top of the pump until the liquid starts to over flow.

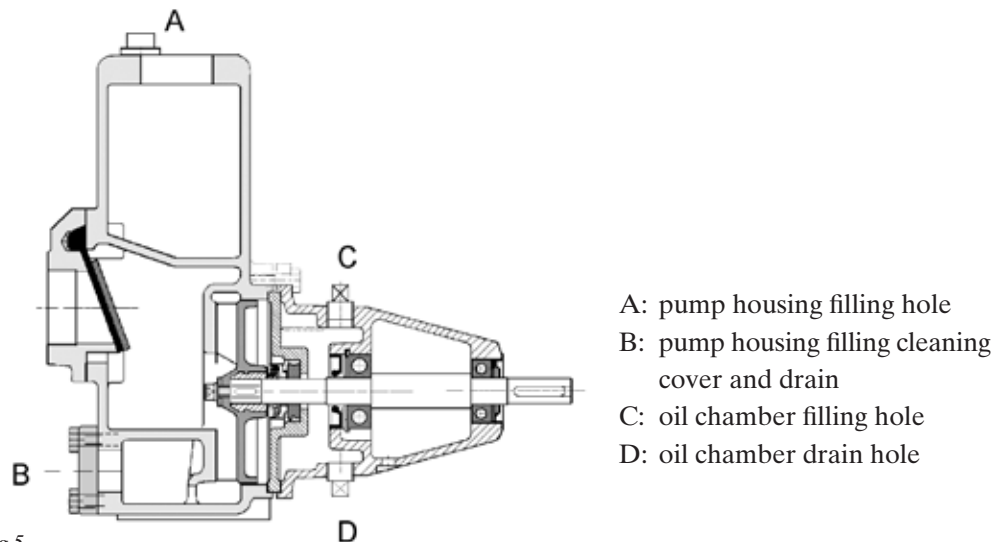

Fig 5

- If oil must not come into contact with the liquid to be pumped, drain out the oil, rinse out the oil chamber and fill with a suitable liquid.

3.7 Drive

If the pump is supplied with a bare shaft end, the user is responsible for the drive and the assembling with the pump.

3.7.1 Connection of electric motors

- Prior to connecting the motor, always consult the electricity company's regulations (European standard EN60-204-1.)
- Employ a thermal motor protection switch.
- Adjust the motor protection switch to the nominal current absorbed by the motor.
- So as to be able to work safely on a pump set one must install a circuit breaker as close as possible to the machine. It also is advisable to place an earth leakage switch.
- Leave the connecting of electric motors to qualified personnel.
- Take the necessary measures to prevent damage to electrical connections and wiring.
- Electrical equipment, terminals and components of control systems may still carry live current when at rest.
- Contact with these may be fatal, result in serious injury or cause irreparable material damage.
- The switching equipment must comply with current regulations, as stipulated by EN 60204-1.
- For single-phase alternating current, use motors with a sufficient high starting torque.
- Always provide proper earthing.

3.7.2 Types

The electric motors which can be connected to the mains electricity supply normally have on the motor plate one of the following voltage specifications:

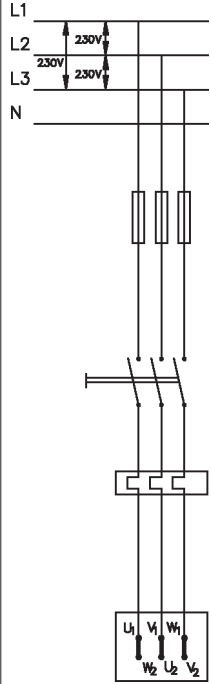
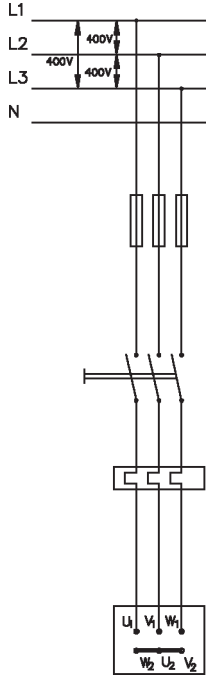
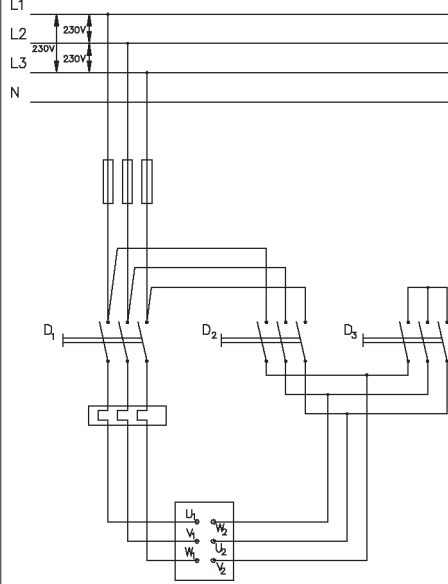
MOTOR	
230V~	230 V. Single phase motors which are connected between the live and the neutral or on 230V between the phases.
230/400 V	<p>These motors can be connected in a circuit of 230 V between the phases. The windings are then in a delta configuration (see figure 6). In a circuit with 400 V between the phases, the windings are in a star configuration (see figure 7).</p> <div style="display: flex; justify-content: space-around;"> <div style="text-align: center;">  <p>Fig 6</p> </div> <div style="text-align: center;">  <p>Fig 7</p> </div> </div>
230 VΔ	This specification has the same meaning as 230/400 V.
400 VΔ	<p>In a circuit with 400 V between the phases, these motors are connected in a delta configuration (figure 7).</p> <p>Remark: Motors with a power of 3 kW and higher are usually not connected directly in delta configuration (the initial current rises to too high a value immediately during start-up. The motor starts, connected in star configuration (see figure 8: switches D1 and D3 closed) and then after a few seconds as the motor comes up to speed is switched to delta configuration (switches D1 and D2 closed and D3 open). This is achieved in a star-delta connection.</p> <div style="text-align: center;">  <p>Fig 8</p> </div>
400/690 V	This specification has the same meaning as 400 VΔ.

For other voltages and circuit frequencies please ask our advice.

3.8 Combustion engines

The regulations for combustion engine are included with the delivery of the group, in case these are not present, make urgent contact with us.

In addition to these directions, for all combustion engines, the following points must be complied with :

- Comply with the local safety regulations
- The exhaust pipe for the combustion gases must be screened against accidental contact
- The starting cord or handle must be automatically uncoupled, once the motor is started
- The rotation speed of the motor is set in the factory and must NOT be changed
- Before starting the motor, check the oil level while putting the pump in horizontal position.



- ***In view of the toxicity of the exhaust gases, never run the engine in a closed room.***
- ***Never top up with fuel while the motor is running.***

3.9 Direction of rotation

- The direction of rotation of the pump is indicated by an arrow; check whether the direction of rotation of the motor is the same, by switching it on for a short time. Immediately switch the motor off, if the direction of rotation is found to be wrong. *To change the direction of rotation switch L1 with L2 or L3. Refer to wiring diagram on the motor.*
Single phase motors and combustion engines have a fixed direction of rotation.
- **If this check required the removal of a protective guard, avoid contact with the rotating parts.** The protective guard **must** be replaced after the check.

4.0 Start-up

- *Check whether it is safe to put the pump into operation. Make sure any risks to persons and environment (high pressure, hot temperature, leakage) are absolutely excluded.*
- **A protective cover which completely encloses the coupling must always be used.**
- Start the pump.
- During the pump's self-priming phase, ensure that the air can escape unhindered and, without any back pressure in the discharge pipe, can flow away.
- **In particular, make sure any pressure cut-off valves are open.**
- Check if connections and seals are not leaking.

4.1 Temperature

The temperature of the pumped liquid may rise to 95°C. Above 70°C, the installer of the pump **must** place the necessary warnings and employ the necessary protection methods to avoid anyone coming into contact with the pump body.

4.2 Noise emission

- The noise emission of the KGE pump is 80 dBA maximum, measured according to ISO2372, in case the pump is used in accordance with the conditions given in the performance curve (refer to technical specifications).
- If the pump is used in unusual conditions (e.g. in the cavitation zone or wholly above the curve), the noise level can rise to 85 dBA. and protection measures must be taken, such as the wearing of ear protectors, or completely encasing the pump within a sound absorbent shield.

4.3 System pressure

The maximum system pressure = maximum working pressure, given on the technical data sheet. If the pressure could exceed this value (through an increase in the rotation speed), a safety valve should be installed in the pipe. Where these pumps pump liquids with solid components, there is a great chance that this valve will block.

It is therefore very much to be preferred **never** to allow the pump to run faster than specified in the tables.



If no fluid is pumped, leakings appear or if excessive noise is apparent, the pump must be stopped immediately. Consult table in section 4.5 Trouble Shooting to determine the problem. Correct before restarting the pump. If abnormal symptoms persist, the pump must be taken out of service immediately. Contact the pump manufacturer or appointed agents.

4.4 Shut-down

- Turn off the motor.
Always avoid restarting the pump during the emptying phase.
During this process, the pump is running in the opposite direction. Restarting it can result in the impeller coming loose and being damaged and can even cause breakage of the shaft.
- If there is any risk of freezing, switch off the pump, drain it and preferably flush or fill it with oil, if permitted. It is also recommended to drain the main piping (suction- and discharge lines)

4.5 Troubleshooting

In case of abnormal operation or when troubles occur the pump must be taken out of service immediately. Inform all responsible personnel. Prior to restarting the pump the cause of the problem must be determined and the problem solved.

4.5.1 Fault finding chart

Symptoms	Causes
Failure to deliver liquid	A,B,C,D,E,G
Pump does not deliver rated capacity	A,C,D,E,F,G,H,N,S
Pump does not develop rated pressure	A,E,H,K,M,S
Pumps overloads driver	H,L,M,N,O,S,X
Vibration	C,D,K,P,Q,R,S,T,U,V,X
Bearings wear rapidly	Q,T,W,X,Y
Motor heating up	H,O,Z
Seized pump	B,F,S,X
Irregular delivery	D,G,K,P
Pump does not prime	A,B,E,G
Noisy pump	C,D,G,H,P,Q,R,T,U,V,X,Y

- A = Wrong direction of rotation
- B = Pump not filled with liquid
- C = Inlet or suction pipe insufficiently submerged
- D = NPSH available too low
- E = Pump not up to rated speed
- F = Total head greater than design
- G = Air leaks in suction line
- H = Viscosity greater than rated
- I = Impeller damaged
- K = Gas or vapour in liquid
- L = Speed too high
- M = Total head lower than rated
- N = Total head higher than rated
- O = Viscosity and/or specific gravity higher than rated
- P = Starved suction
- Q = Misalignment
- R = Worn or loose bearings
- S = Impeller blocked or damaged
- T = Bent shaft
- U = Improper location of discharge valve
- V = Foundation not rigid
- W = Bearings badly installed
- X = Pipes exert forces on pump
- Y = Vibration
- Z = Speed too high, check motor name plate
- AB = Foreign matter in pump

If symptoms persist the pump must be taken out of service immediately. Contact the pump manufacturer or their appointed agents.

4.5.2 Re-use

Re-use of the pump for purposes other than the one for which it was originally intended should only be undertaken after completely draining the oil chamber and the pump housing. Because the pump could have been used for corrosive or poisonous liquids, it should first be thoroughly rinsed out.

- Flushing the pump out is necessary because the origin of the liquid which it contained is not always known and, even after draining the pump, liquid can remain inside.
- During this procedure, observe adequate safety regulations and take environmental protection measures.
- Liquids should be drained and disposed of safely, and the correct personal protection equipment should be used. The wearing of gloves and safety glasses to protect against possible splashes is advised.
- **If necessary, pumped liquid must be neutralised and internal parts properly cleaned.**

4.6 Scrapping of the pump

The same measures should be observed as for Re-use 4.5.2 . Disposal of the pump should only be done after it has completely been drained. Proceed according to local regulations.

5.0 Maintenance

5.1 Precautionary measures

- **Insufficient, wrong and/or irregular maintenance can lead to malfunctions in the pump, high repair costs and long-term inoperability. Therefore, you should carefully follow the guidelines given in this chapter during maintenance operations on the pump. Non-compliance with prescriptions or warnings may be dangerous for the user and/or seriously damage the pump / pump group.**
- All work should be carried out by suitably trained personnel.
- **Pump and piping may contain high pressure liquids, high temperature liquids or/and hazardous chemical fluids even when the unit has been shut down.** Before dismantling, always allow the pump to cool (20 °C) and allow it to drain completely.
- Ensure that the working area is clean, because certain parts such as the mechanical shaft seals are extremely vulnerable and others have very close tolerances.
- In case of storage :
- The pump must be operated briefly once a week or alternatively one manually makes a full revolution of the pump shaft.
- *This ensures a proper circulation of the protective oil.*

5.2 Daily

- Keep both the surface of the pump and the surroundings as clean as possible. This simplifies inspection (attached markings remain visible).
- ***Never spray the hot parts of a pump with water, as certain components may crack due to the sudden cooling and the fluid being pumped may spray in to the environment.***

5.3 Periodic inspection

- The pump should run smoothly and free from noise or vibration
- Shaft alignment and levelness of the base plate
- Gasketed seals at pump casing and seal cover and suction / discharge connections should be inspected for leaks.
- Make sure appropriate grade and amount of lubricant is present in bearings and in the oil chamber of the mechanical seal.
- Check bearings for excessive wear. Worn bearings may result in excessive shaft run-out necessitating frequent seal failure.
- Always ensure that the liquid level in the suction line is adequate. Never allow the suction head to drop below the minimum NPSH (required) by the pump.

5.4 Flushing

Because the pump could have been used for corrosive or poisonous liquids, it should first be thoroughly rinsed out. Flushing the pump out is necessary because the origin of the liquid which it contained is not always known and, even after draining the pump, liquid can remain inside.

- Present connections can be used to flush the pump out.
- During this flushing procedure, observe adequate safety regulations and take environmental protection measures. The wearing of gloves and safety glasses to protect against possible splashes and hot temperatures is advised.

5.5 Ball Bearings

The ball bearings are sealed and packed with grease, relubrication is not necessary. The lifetime of the bearings of the most heavily loaded pump is 10,000 running hours, and for the lightest loaded pump it is six times longer.

The lubrication of the bearings plays a very important role and therefore it is recommended to replace the bearings after 10,000 hours of service, or every three years.

5.6 Electrical installation

Maintenance operations on the electric installation may be performed only by trained and qualified personnel and after disconnecting the electric power supply. Carefully follow the national safety regulations. Respect the above mentioned regulations also if performing work while the power supply is still connected.

5.7 The oil chamber

Before start-up the lip seal chamber must be filled with a lubricating liquid which will not attack the liquid to be pumped nor the mechanical seal (normally the chamber is filled with oil of type SAE 20). Every 2000 hours of running, or once a year, drain and refill with fresh oil.

Oil chamber contents

ump size	[l]
KGE 11-3	0.22
KGE 11-4	0.22
KGE 16-3	0.6
KGE 12b-5	0.6
KGE 12-5	0.6
KGE 12-6	0.6
KGE 15-6	0.6
KGE 16-6	0.6
KGE 14-8	0.6
KGE 18-4	0.6
KGE 20b-5	0.6
KGE 22-6	0.6

5.8 Mechanical seal

If the mechanical shaft seal should start to leak, the oil chamber will overflow via the hole in the oil filler cap (C : see figure 9) and the pump must be immediately stopped to replace the mechanical seal.

5.9 Oil seal

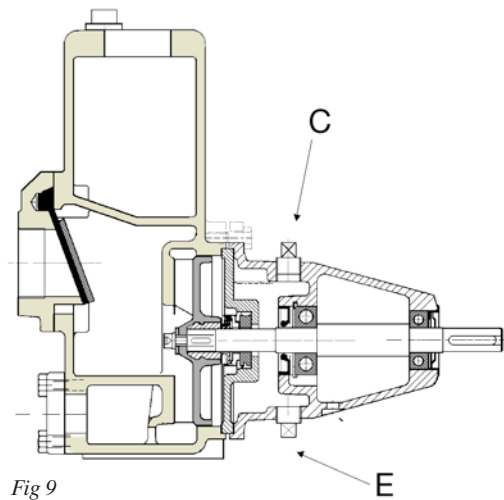

Fig 9

If leakage from (E) is noticed, this indicates the lip seal has failed and needs replacement.

5.10 Impeller

If there is decline in the performance characteristics of the pump when neither the installation nor the working point have been changed it is 90% certain that there is wear on the impeller.

How quickly this wear occurs is dependent upon the type of liquid being pumped. There is a clearance between the impeller and the pump casing. This clearance becomes greater through wear. In order to check this, the pump must be dismantled and the dimension A measured. It must not exceed 0,5 mm.

The dismantling and reassembly instructions are given in the following chapter.

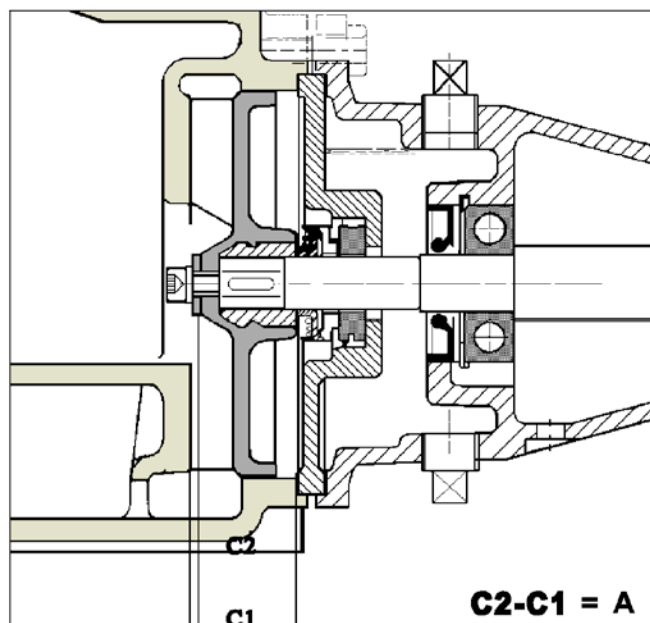

Fig 10

6.0 Assembly and disassembly

6.1 General

- When servicing the pumps, see to a clean working environment because certain parts, say, the mechanical seals, are extremely vulnerable, other parts having close tolerances. Check that the parts have not been damaged in transit. In particular, inspect the spigots mating and sealing faces, etc.
- **Loctite liquid securing type 243 is used for securing the impeller screw or impeller bolt.**

When Loctite is used, first degrease the parts properly. The Loctite must be applied in sufficient quantities both internally and externally and the bolts tightened up to the torque settings shown in table below:

Material bolt	Max. tightening torque Nm					Application
	M6	M8	M10	M12	M16	
8.8	11	25	51	87	215	Bearing bracket, lantern piece
A2 / A4	8,5	21	42	70	173	Impeller

6.2 Replacing the impeller

Also refer to sectional drawings

Impeller fixation	
Bearing bracket 00	stainless steel bolt with tolerance ring (on KGEF) or with key (KGE) and washer.
Bearing bracket 0 and 0+	stainless steel bolt with key and washer
Bearing bracket 1 and 2	stainless steel nut with key and washer

6.2.1 Disassembly impeller

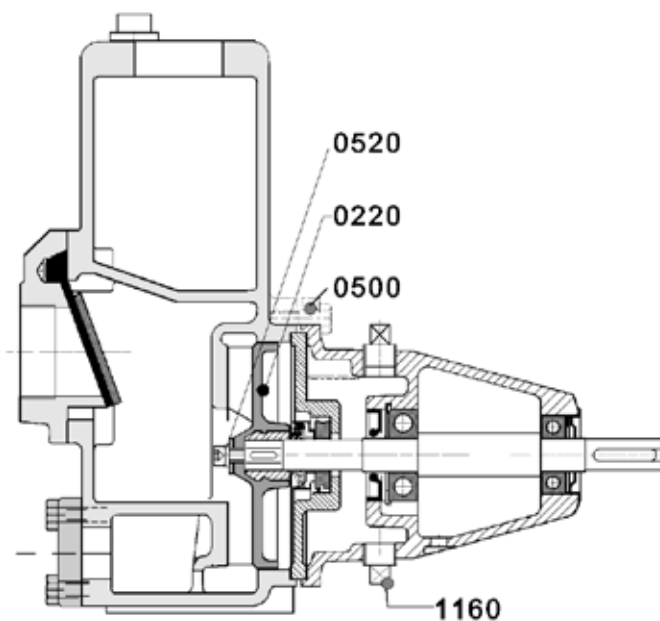

Fig 11 - Disassembly impeller with bearing bracket group 0, 0+ and 00 (construction ① and ②)

- 1 Drain out the drain liquid from the oil chamber by removing the oil drain plug (1160); with ③ and ④: 0830).
- 2 **Bearing bracket 00, 0 and 0+:**
 - Detach bearing bracket by loosening bolts (0500).
 - Undo the impeller screw (0520)
- 3 **Bearing bracket 1 and 2 (see sectional drawings) :**
 - Detach bearing bracket by loosening bolts (0820)
 - Disassemble intermediate cover with bearing bracket from pump casing by loosening bolts (0770)
 - Undo the impeller bolt.
 - Remove washer
- 4 Next detach the impeller (0220) or (0130), using a coupling puller.

6.2.2 Impeller assembly

- 1 When pushing on the impeller, accurately check that its position is square with the shaft.
- 2 When an impeller is assembled with a key (0550), neither the key nor the keyways in the shaft or impeller must be adjusted.
- 3 Insert the same number of gaskets (0220 or with bearing bracket 1 and 2: 0440) between pump casing and intermediate cover, removed during disassembling from factory fitted pump.
- 4 Slide the impeller onto the shaft.
- 5 Take the washer and fit, depending on the construction, the impeller screw, Allen screw (0520) or impeller bolt with washer, using Loctite 243.
- 6 Next provide the gaskets (0240) or (0440) in the pump casing and fix the bearing bracket to it using the Allen screws.
- 7 In case the oil chamber was emptied, fill it with the specified liquid through plug. Make sure the plug is fitted.

6.3 Replacement of mechanical seal

6.3.1 Disassembly of mechanical seal

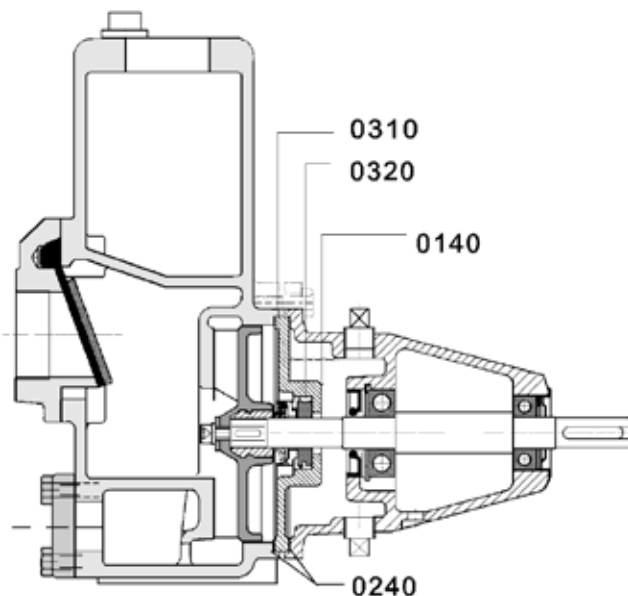

Fig 12 - Mechanical seal disassembly bearing bracket group 0 and 00

- 1 Follow steps 1 to 4 of the impeller dismantling procedure.
- 2 Now remove the rotating part of the shaft seal (0310) fitted to the shaft.
- 3 Pull the intermediate cover (0140 / 0120) from the bearing bracket.
- 4 Push the counterseal ring (0320) of the shaft seal from the intermediate cover.
- 5 Replace the gaskets (0240 / 0440).

6.3.2 Assembly of single mechanical seal

Follow steps 4 to 1 of the disassembly instructions. Please ensure to apply few drops of SAE20 oil between the seal faces and also on outside surface of the 'L' / 'T' - or Seal-ring (bearing bracket group 0 and 00:) O-ring.

6.4 Replacement of the bearings

The ball bearings are sealed and grease-packed, so they are lubricated for life.

6.4.1 Disassembly of the ball bearings

- 1 Disassemble the impeller and shaft seal. Please refer to the disassembly instructions.
- 2 Disassemble the ball bearing cover (1110 / 2330), the inner circlip and the laminated seal (second bearing cover) or BA-ring.
- 3 Strike the shaft on impeller side such that the shaft and bearings are released from the bearing bracket.
- 4 Remove the ball bearing along the shaft end side, using a coupling puller.
- 5 Remove shoulder rings out of the bearing bracket (⊗⊗: bearing bracket 1 & 2: from the shaft)
- 6 Clean the shaft properly on impeller side, particularly where the shaft seal is positioned, then remove the ball bearing on impeller side.

6.4.2 Assembly of the ball bearings

- 1 Properly clean the ball bearing bores and the shaft length over which the bearings have to be pushed.
- 2 Put the removed shoulder rings back into the bearing bracket.
- 3 Cautiously place the ball bearing on the shaft. In case of construction ⊗, then fit a Nilos ring (1090).
- 4 Fit the outboard bearing from shaft end side.
- 5 Fit the inboard clip (1100) or (2330)
- 6 Now push the shaft with two bearings through the bore at the back of the bearing bracket.
- 7 Fit the outboard spring circlip (1110) or (2330)
- 8 For the assembly of the shaft seal and impeller please refer to the relevant instructions.

6.5 Motor replacement (KGEF)

Also refer to sectional drawings

6.5.1 Motor disassembly

- 1 Disassemble pumpcasing from lantern piece loosening bolts 0500 (bearing bracket group 1 and 2: 0770)
- 2 Disassemble the impeller and shaft seal (see the disassembly instructions).
- 3 Detach the lantern piece from the motor by loosening bolts 0530 (bearing bracket group 1 and 2: 0790-0780)
- 4 Replace motor

6.5.2 Motor assembly

- 1 Start to assemble with the motor. To that effect, position the motor with the shaft pointing upwards.
- 2 Place the lantern piece on the motor, using the bolts.
- 3 Now fit the shaft seal and impeller (see relevant instructions).

Use Loctite 243 for fitting impeller bolt or impeller nut.

6.6 Waste handling/material recycling

At the products end of life, please dispose of the product according to applicable law. Where applicable, please disassemble the product and recycle the parts material.

7.0 Technical specifications

7.1 Technical data

KGE		11 - 3	11 - 4	16 - 3	12b - 5	12 - 5	12 - 6	15 - 6	16 - 6	14 - 8	18 - 4	20b - 5	22 - 6
Construction													
Bearing bracket		00	00	0	0	0	0	0+	0+	0+	1	1	2
Impeller													
- semi open		□	□	-	□	□	□	□	□	□	-	-	-
- closed		-	-	□	-	-	-	-	-	-	□	□	□
Connections													
Suction- and discharge	mm/Rp	1 1/4	1 1/2	1 1/4	2		2 1/2			DN 80	1 1/4	2	2 1/2
Filling plug pump casing	Rp	3/4	3/4	3/4	3/4	3/4	3/4	3/4	3/4	3/4	3/4	3/4	3/4
Characteristics													
Max. working pressure (PN)	bar	5	5	5	5	5	5	5	5	5	6	6	8
Test pressure (1,3 max. work. Pressure)	bar	6,5	6,5	6,5	6,5	6,5	6,5	6,5	6,5	6,5	8	8	10,5
Passage (particle size)	mm	6	11	5	8	12	19	13	13	18	5	3	9
Max. liquid temperature	C	95	95	95	95	95	95	95	95	95	95	95	95
Max. liquid viscosity	m Pa.s	150	150	150	150	150	150	150	150	150	150	150	150
Weight (max.)** KGE A	kg	15	17	26	30	30	40	40	40	46	65	90	110
KGEF	kg	24	27	41	43	45	73	71	82	77	100	135	-
Bearings													
Inboard bearing		6303		6305			7305			6306		6308	
Outboard bearing		6203		6305			6305			6306		6308	
Drive (***)													
Maximum speed													
Direct drive	min ⁻¹	3500	3500	3500	3500	3500	3500	3500	3500	3500	3500	3500	2900
Belt drive	min ⁻¹	2900	2900	2900	2900	2900	2900	2900	2900	2900	2900	2900	2500
Belt min. pump pulley	mm	250	250	A163	A 63	A 63	A 63	A160	A160	A160	-	-	-
Motor for KGEF special flange motor with extended shaft													
Minimum output	kW	0,75	1,1	2,2	1,5	2,2	3	4	5,5	4	4	5,5	11
Speed	min ⁻¹	2900	2900	2900	2900	2900	2900	2900	2900	2900	2900	2900	2900
Protection		IP55	IP55	IP55	IP55	IP55	IP55	IP55	IP55	IP55	IP55	IP55	IP55
Mechanical seal													
Shaft diameter	mm	16	16	25	25	25	25	25	25	25	30	30	40
Overall length	mm	21	21	24	24	24	24	24	24	24	37,5	37,5	47,5
Oil chamber plugs													
Filling and draining	Rp	3/8"	3/8"	3/8"	3/8"	3/8"	3/8"	3/8"	3/8"	3/8"	3/8"	3/8"	3/8"

7.2 Dimensions KGE Pump with bare shaft end

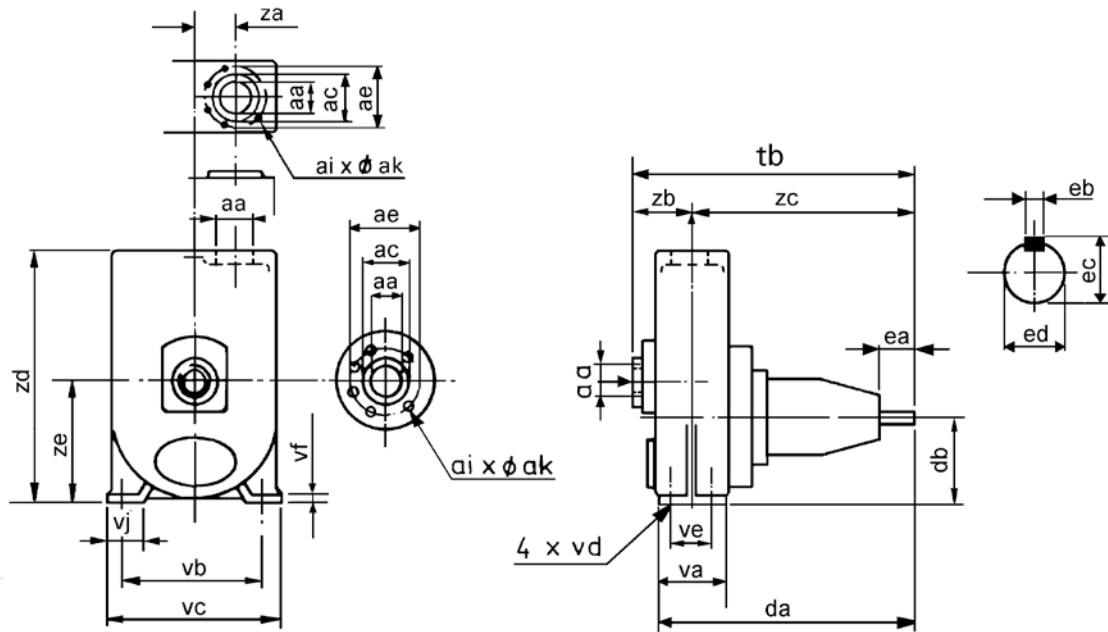

Fig 13

Rp/ Mm	00		0				0+			1		2
	11 - 3	11 - 4	16 - 3	12b - 5	12 - 5	12 - 6	15 - 6	16 - 6	14 - 8	18 - 4	20b - 5	22 - 6
Aa	1 1/4"	1 1/2"	1 1/4"	2	2	2 1/2"	2 1/2"	2 1/2"	DN80	1 1/4"	2	2 1/2"
Ac	-	-	-	-	-	-	-	-	135	-	-	-
Ae	-	-	-	-	-	-	-	-	160	-	-	-
Ai	-	-	-	-	-	-	-	-	8	-	-	-
Ak	-	-	-	-	-	-	-	-	M16	-	-	-
Da	282	282	335	335	335	360	360	360	360	443	470	575
Db	80	80	100	100	100	100	132	132	132	160	160	180
Ea	40	40	50	50	50	50	50	50	50	50	50	80
Eb	5P9	5P9	8P9	8P9	8P9	8P9	8P9	8P9	8P9	8P9	8P9	10P9
Ec	18	18	27	27	27	27	27	27	27	27	27	35
Ed	16j6	16j6	24j6	24j6	24j6	24j6	24j6	24j6	24j6	24j6	24j6	32k6
Tb	308	325	372	393	393	434	415	415	430	490	515	640
Va	95	95	100	100	100	125	125	125	125	100	125	125
Vb	160	160	190	190	190	190	212	212	212	212	250	280
Vc	190	190	225	225	225	225	247	247	255	265	320	345
Vd	12	12	14	14	14	14	14	14	14	14	14	14
Ve	70	70	70	70	70	95	95	95	95	70	95	95
Vf	10	10	12	12	12	12	12	12	12	15	15	18
Vj	35	35	42	42	42	42	44	44	47	50	65	65
Za	-	-	-	-	-	-	-	-	-	90	100	110
Zb	70	80	83	98	98	114	105	105	116	90	105	120
Zc	238	245	289	295	295	320	310	310	314	400	410	520
Zd	255	290	280	350	350	360	380	380	375	370	460	550
Ze	132	132	160	160	160	180	212	212	212	212	224	265
[kg]	15	17	26	30	30	40	40	40	46	65	90	110

7.4 Dimensions KGE pump with motor (assembly A6)

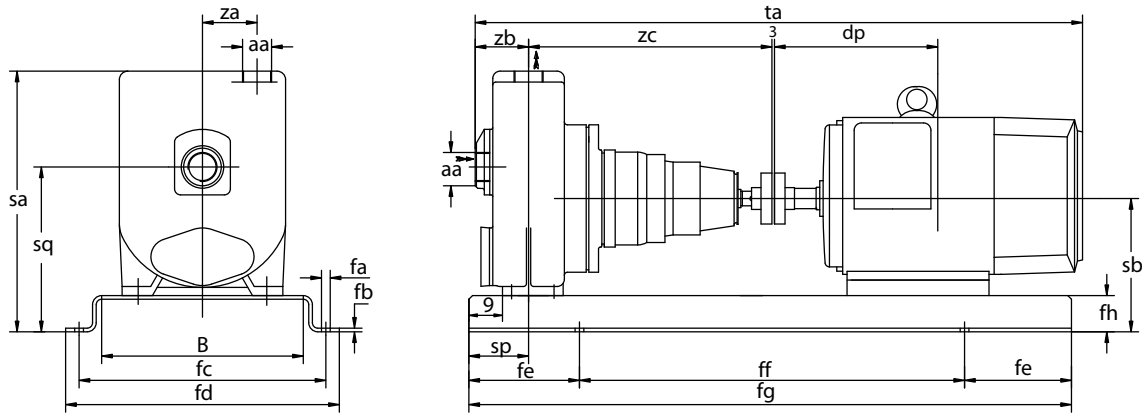
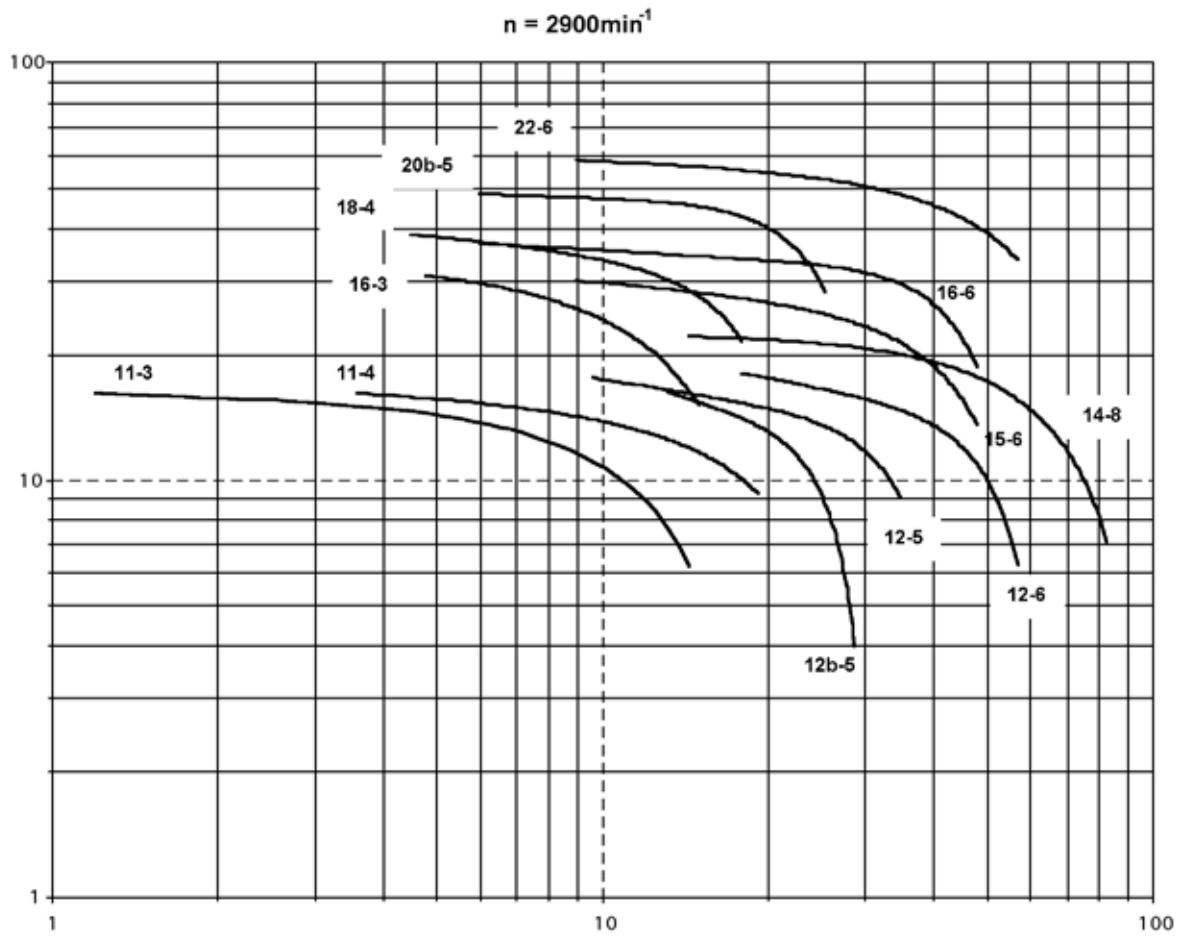

Fig 15

Rp/mm	00		0				0+			1		2
	11-3	11-4	16-3	12b-5	12-5	12-6	15-6	16-6	14-8	18-4	20b-5	22-6
IEC Motor	80	80	90L	90S	90L	100L	112M	132S	112M	112M	132S	160M
aa (Rp)	1 1/4"	1 1/2"	1 1/4"	2"	2"	2 1/2"	2 1/2"	2 1/2"	DN80	1 1/4"	2"	2 1/2"
Fa	15	15	15	15	15	15	19	19	19	19	19	24
Fb	5	5	5	5	5	5	6	6	6	6	6	10
Fc	290	290	290	290	290	290	385	385	385	385	425	485
Fd	334	334	334	334	334	334	433	433	433	433	473	545
Fe	90	90	90	90	90	105	120	120	120	120	135	175
Ff	450	450	450	450	450	500	560	560	560	560	630	900
Fg	630	630	630	630	630	710	800	800	800	800	900	1250
Fh	35	35	35	35	35	40	45	45	45	45	56	80
B	225	225	225	225	225	225	305	305	305	305	345	375
Sa	290	325	315	385	385	400	425	425	420	415	516	630
Sb	115	115	135	135	135	140	177	177	177	205	216	260
Sp	57	57	59	59	59	72	72	72	72	59	72	72
Sq	167	167	195	195	195	220	257	257	257	257	280	354
Dp	140	140	165	155	165	190	200	240	200	200	240	325
ta max	586	603	705	696	726	807	808	883	810	888	984	1262
Za	0	0	0	0	0	0	0	0	0	90	100	110
Zb	70	80	83	98	98	114	105	105	116	90	105	120
Zc	238	245	289	295	295	320	310	310	314	400	410	520

7.5 Survey curve ($n = 2900 \text{ min}^{-1}$)



7.6 Parts list and sectional drawing KGE① Bearing bracket 00 KGE11-3 / KGE11-4

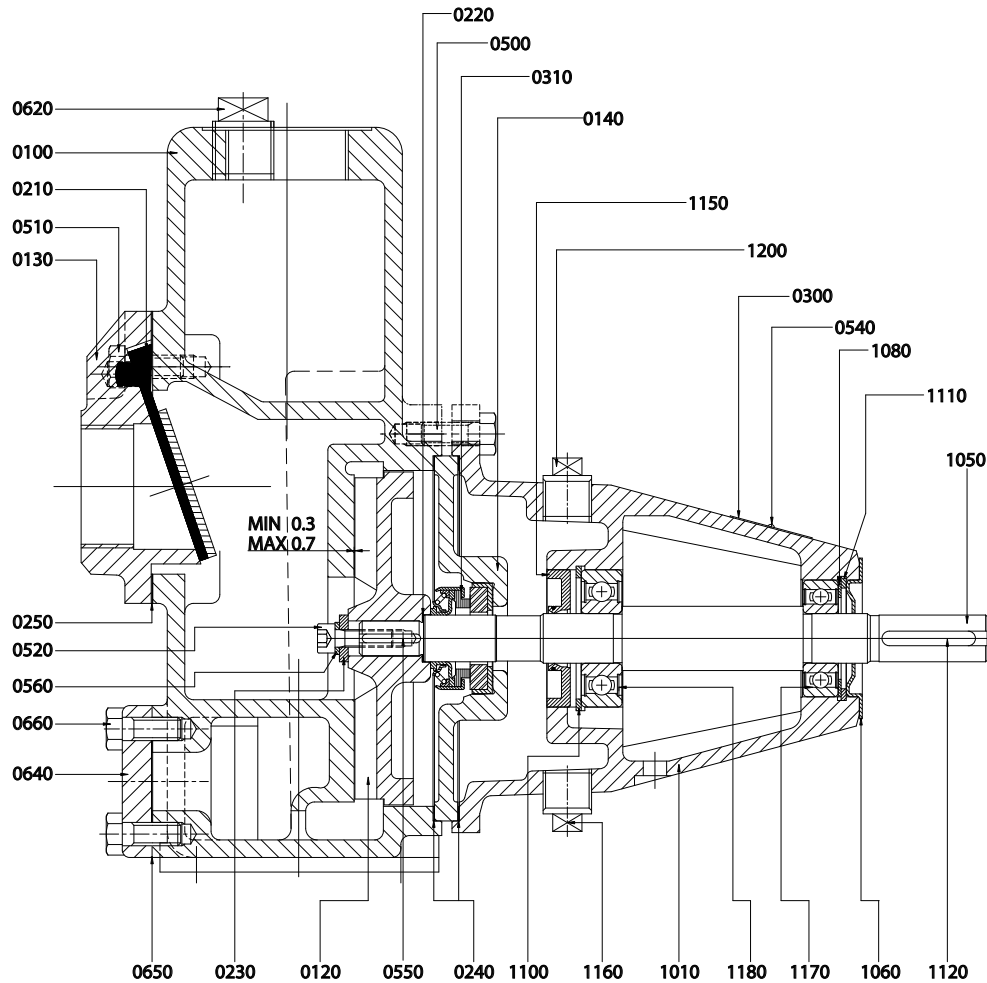

Fig 16

Item	Qty	Description	Material	Item	Qty	Description	Material
0100	1	pump casing	cast iron	0620	1	plug	steel
0120*	1	impeller	plastic/bronze	0640	1	window cover	cast iron
0130	1	suction cover	cast iron	0650*	1	gasket	--
0140	1	intermediate cover	cast iron	0660	6	hex bolt	steel
0210*	1	valve	rubber + steel	1010	1	bearing housing	cast iron
0220	4	ring	stainless steel	1050	1	pump shaft	stainless steel
0230	1	washer	steel	1060	1	bearing cover	steel
0240*	2	gasket	--	1080	1	ring	steel
0250*	1	gasket	--	1100	1	Seeger "L" ring	spring steel
0300	1	name plate	stainless steel	1110	1	circlips	spring steel
0310*	1	seal ring	carbon	1120	1	key	steel
0320*	1	counterseal ring	ceramic	1150*	1	lip seal	NBR
0500	4	hex bolt	steel	1160	1	drain plug	steel
0510	4	hex bolt	steel	1170*	1	ball bearing	steel
0520	1	Allen bolt	steel	1180*	1	ball bearing	steel
0540	4	self tapping rivet	aluminium	1200	1	plug	polypropylene
0550	1	key	stainless steel				
0560	1	spring washer	spring steel				* recommended spare parts for normal use

Important: When ordering spare parts, please state:

- Pump type and serial number (see name plate),
- Quantity, name and item number of desired parts (materials).

7.7 Parts list and sectional drawing KGE² Bearing bracket 0 KGE12(b)-5 / KGE12-6

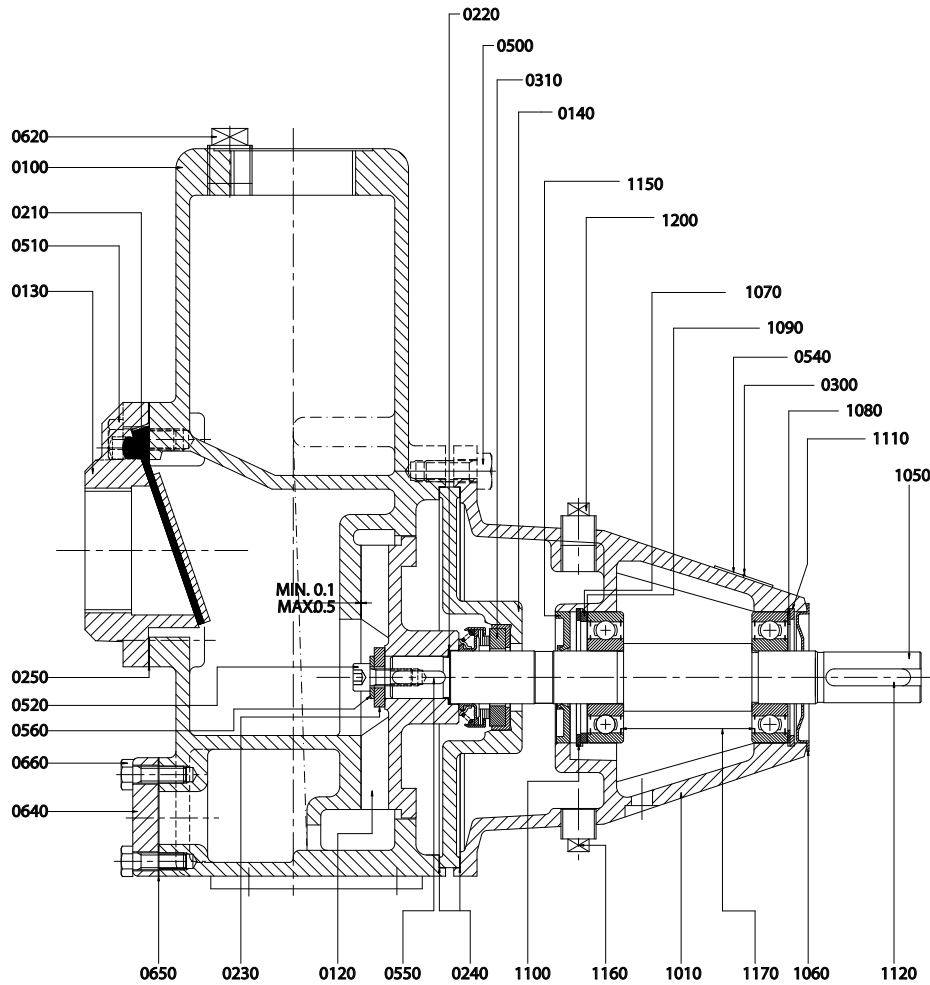

Fig 17

Item	Qty	Description	Material	Item	Qty	Description	Material
0100	1	pump casing	cast iron	0620	1	plug	steel
0120*	1	impeller	cast iron/bronze	0640	1	window cover	cast iron
0130	1	suction cover	cast iron	0650*	1	gasket	--
0140	1	intermediate cover	cast iron	0660	6	hex bolt	steel
0210*	1	valve	rubber + steel	1010	1	bearing housing	cast iron
0220	4	ring	stainless steel	1050	1	pump shaft	stainless steel
0230	1	washer	steel	1060	1	bearing cover	steel
0240*	2	gasket	--	1070	1	support ring	steel
0250*	1	gasket	--	1080	1	washer	steel
0300	1	name plate	stainless steel	1090	1	washer	steel
0310*	1	seal ring	carbon	1100	1	circlips	spring steel
0320*	1	counterseal ring	ceramic	1110	1	Seeger "L" ring	spring steel
0500	4	hex bolt	steel	1120	1	key	steel
0510	4	hex bolt	steel	1150*	1	lip seal	NBR
0520	1	Allen bolt	steel	1160	1	drain plug	steel
0540	4	self tapping rivet	aluminium	1170*	2	ball bearing	steel
0550	1	key	stainless steel	1200	1	plug	polypropylene
0560	1	spring washer	spring steel	* recommended spare parts for normal use			

Important: When ordering spare parts, please state:
 a) Pump type and serial number (see name plate),
 b) Quantity, name and item number of desired parts (materials).

7.8 Parts list and sectional drawing KGE②+, Bearing bracket 0+ KGE14-8

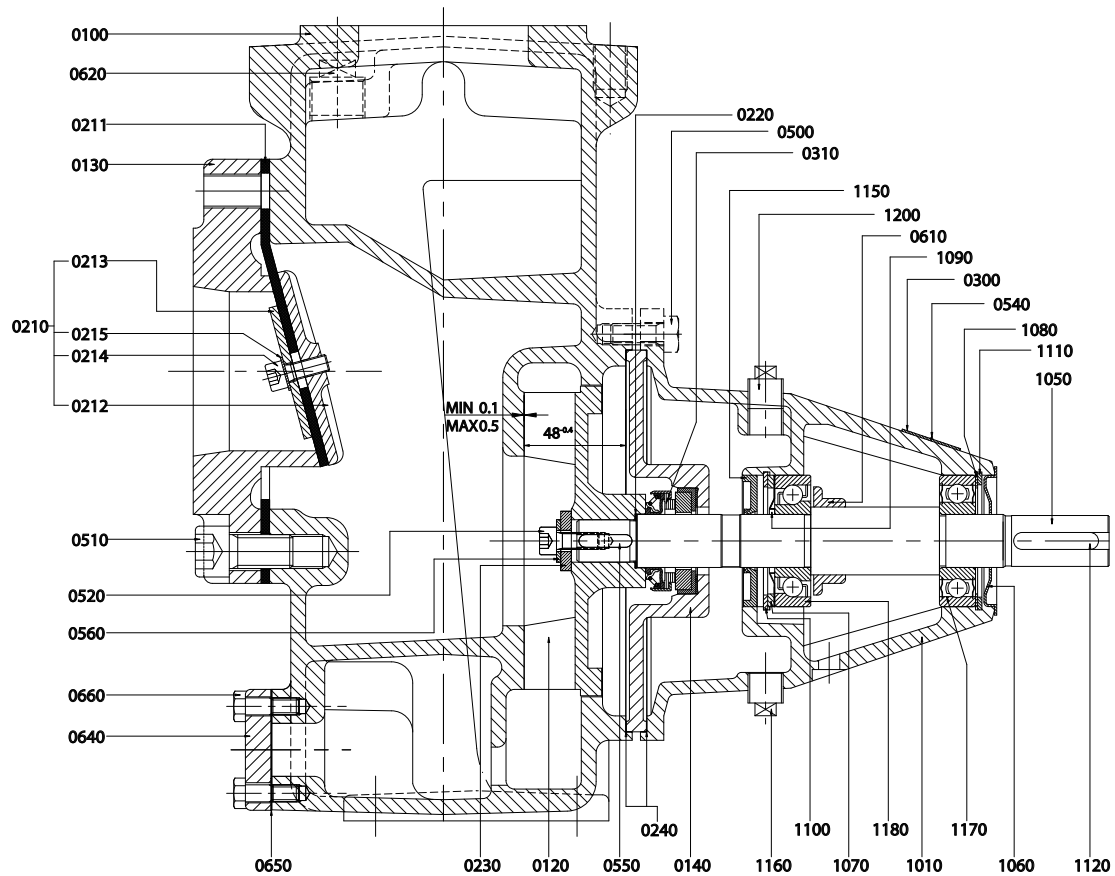

Fig 18

Item	Qty	Description	Material	Item	Qty	Description	Material
0100	1	pump casing	cast iron	0610*	1	splash ring	NBR
0120*	1	impeller	cast iron/bronze	0620	1	plug	steel
0130	1	suction cover	cast iron	0640	1	window cover	cast iron
0140	1	intermediate cover	cast iron	0650*	1	gasket	--
0210*		valve assembly		0660	6	hex bolt	steel
0211	1	valve	NBR	1010	1	bearing housing	cast iron
0212	1	valve plate	cast iron	1050	1	pump shaft	stainless steel
0213	1	washer	cast iron	1060	1	bearing cover	steel
0214	1	Allen bolt	steel	1070	1	support ring	steel
0215	1	washer	steel	1080	1	washer	steel
0220	4	ring	stainless steel	1090	1	nilos ring	steel
0230	1	washer	steel	1100	1	circlips	spring steel
0240*	2	gasket	--	1110	1	Seeger "L" ring	spring steel
0250*	1	gasket	--	1120	1	key	steel
0300	1	name plate	stainless steel	1150*	1	lip seal	NBR
0310*	1	seal ring	carbon	1160	1	drain plug	steel
0320*	1	counterseal ring	ceramic	1170*	1	ball bearing	steel
0510	4	Allen bolt	steel	1180*	1	ball bearing	steel
0520	1	Allen bolt	steel	1200	1	plug	polypropylene
0540	4	self tapping rivet	aluminium				
0550	1	key	stainless steel				
0560	1	spring washer	spring steel				

* recommended spare parts for normal use

Important: When ordering spare parts, please state:

- Pump type and serial number (see name plate),
- Quantity, name and item number of desired parts (materials).

7.9 Parts list and sectional drawing KGE² Bearing bracket 0 KGE16-3

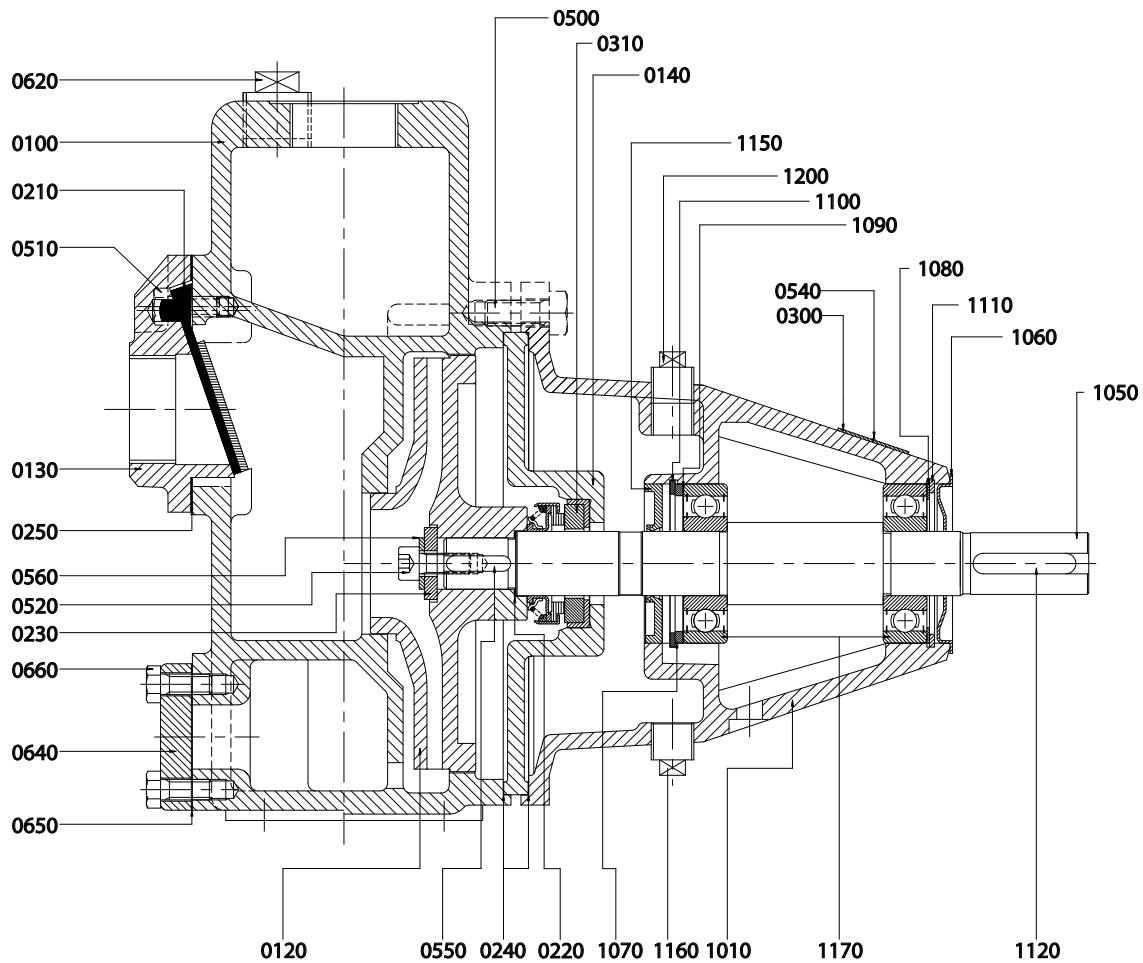

Fig 19

Item	Qty	Description	Material	Item	Qty	Description	Material
0100	1	pump casing	cast iron	0620	1	plug	steel
0120*	1	impeller	cast iron/bronze	0640	1	window cover	cast iron
0130	1	suction cover	cast iron	0650*	1	gasket	--
0140	1	intermediate cover	cast iron	0660	6	hex bolt	steel
0210*	1	valve	rubber + steel	1010	1	bearing housing	cast iron
0230	1	washer	steel	1050	1	pump shaft	stainless steel
0240*	2	gasket	--	1060	1	bearing cover	steel
0250*	1	gasket	--	1070	1	support ring	steel
0300	1	name plate	stainless steel	1080	1	washer	steel
0310*	1	seal ring	carbon	1090	1	washer	steel
0320*	1	counterseal ring	ceramic	1100	1	circlips	spring steel
0500	4	hex bolt	steel	1110	1	Seeger "L" ring	spring steel
0510	4	hex bolt	steel	1120*	1	key	steel
0520	1	Allen bolt	steel	1150*	1	lip seal	NBR
0540	4	self tapping rivet	aluminium	1160	1	drain plug	steel
0550	1	key	stainless steel	1170*	2	ball bearing	steel
0560	1	spring washer	spring steel	1200	1	plug	polypropylene

* recommended spare parts for normal use

Important: When ordering spare parts, please state:
 a) Pump type and serial number (see name plate),
 b) Quantity, name and item number of desired parts (materials).

7.10 Parts list and sectional drawing KGE②+, Bearing bracket 0+ KGE15 - 6 / KGE16 - 6

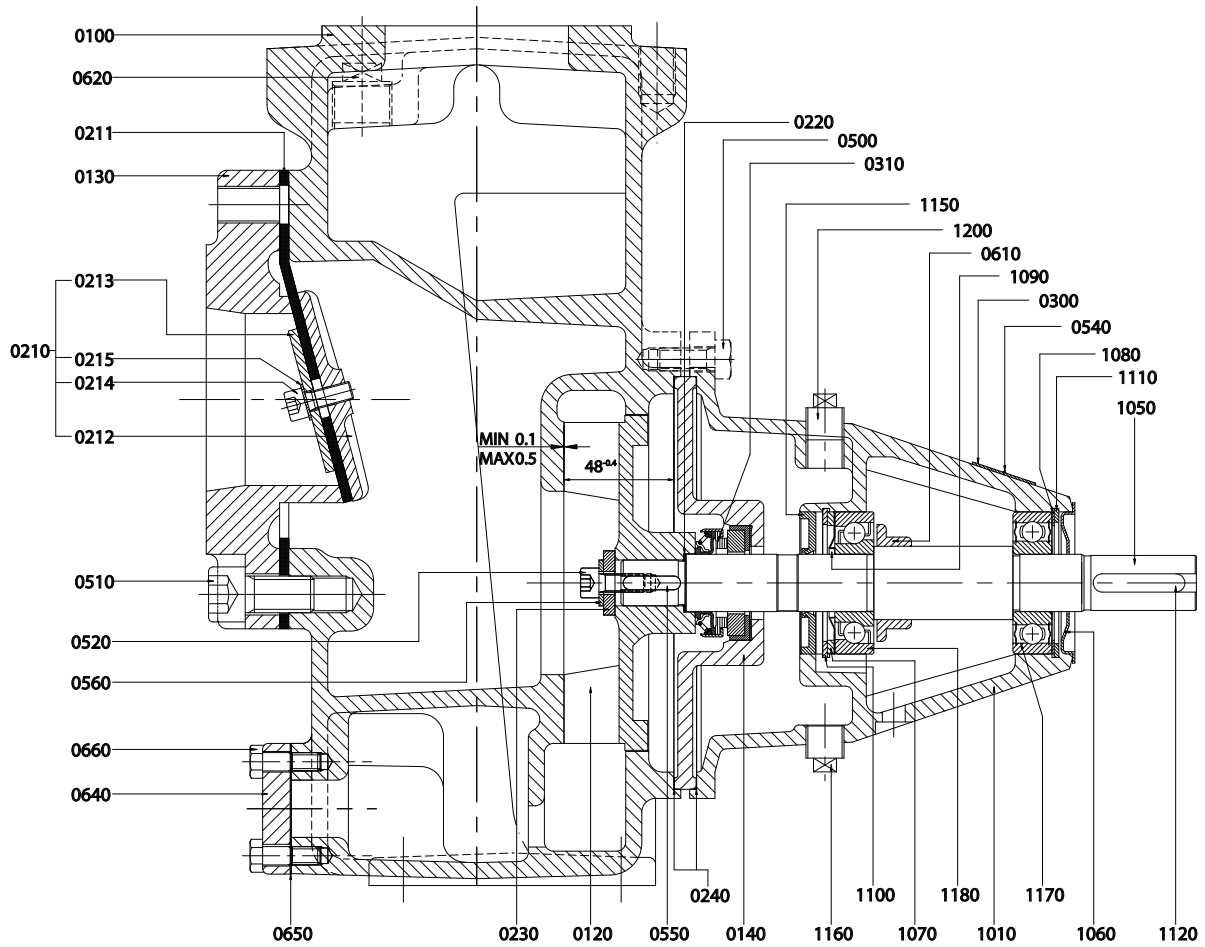

Fig 20

Item	Qty	Description	Material	Item	Qty	Description	Material
0100	1	pump casing	cast iron	0640	1	window cover	cast iron
0120*	1	impeller	cast iron/bronze	0650*	1	gasket	--
0130	1	suction cover	cast iron	0660	6	hex bolt	steel
0140	1	intermediate cover	cast iron	0610*	1	splash ring	NBR
0210*	1	valve	rubber + steel	1010	1	bearing housing	cast iron
0220	4	ring	stainless steel	1050	1	pump shaft	stainless steel
0230	1	washer	steel	1060	1	bearing cover	steel
0240*	2	gasket	--	1070	1	support ring	steel
0250*	1	gasket	--	1080	1	washer	steel
0300	1	name plate	stainless steel	1090	1	nilos ring	steel
0310*	1	seal ring	carbon	1100	1	circlips	spring steel
0320*	1	counterseal ring	ceramic	1110	1	Seeger "L" ring	spring steel
0500	4	hex bolt	steel	1120*	1	key	steel
0510	4	hex bolt	steel	1150*	1	lip seal	NBR
0520	1	Allen bolt	steel	1160	1	drain plug	steel
0540	4	self tapping rivet	aluminium	1170*	1	ball bearing	steel
0550	1	key	stainless steel	1180*	1	ball bearing	steel
0560	1	spring washer	spring steel	1200	1	plug	polypropylene
0620	1	plug	steel	* recommended spare parts for normal use			

Important: When ordering spare parts, please state:
 a) Pump type and serial number (see name plate),
 b) Quantity, name and item number of desired parts (materials).

7.11 Parts list and sectional drawing KGE[®] Bearing bracket 1 KGE18-4 / KGE20b-5

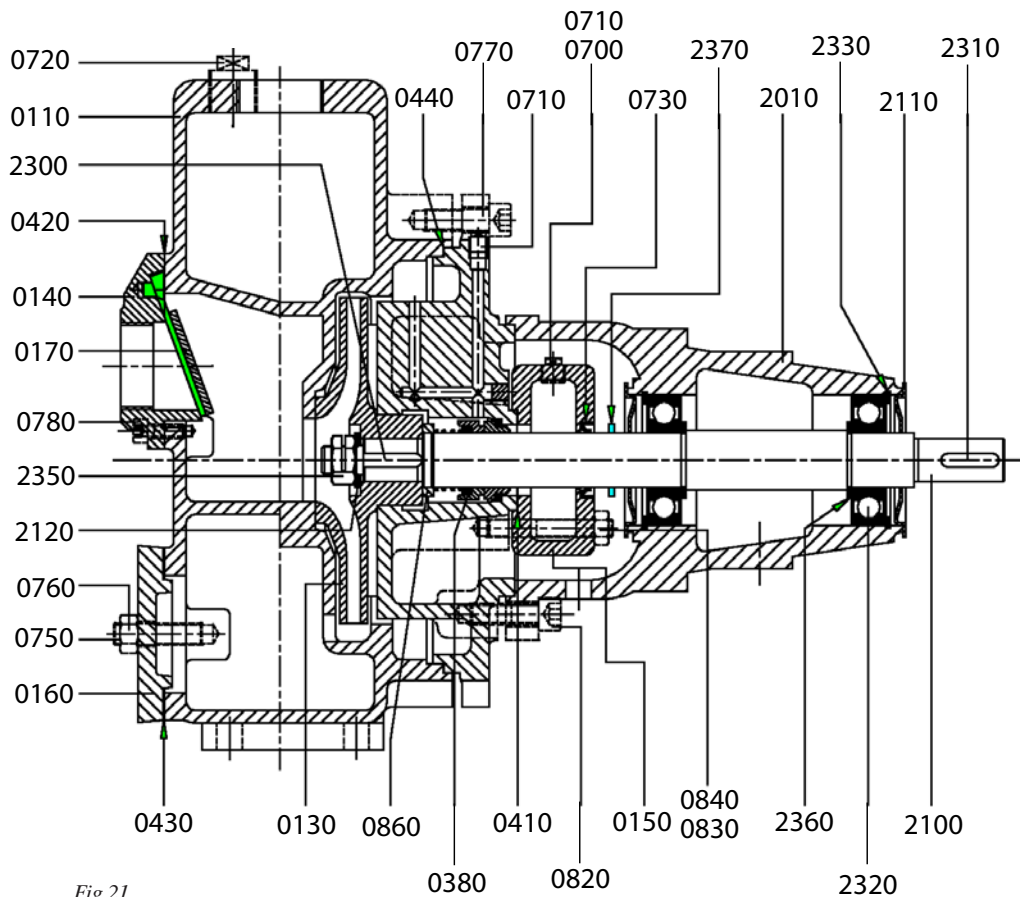

Fig 21

Item	Qty	Description	Material	Item	Qty	Description	Material
0110	1	pump casing	cast iron	0770	8	Allen screw	steel
0120	1	shaft seal cover	cast iron	0780	4	Allen screw	steel
0130*	1	impeller	cast iron	0820	4	Allen screw	steel
0140	1	suction cover	cast iron	0830	2	stud	steel
0150	1	oil reservoir	cast iron	0840	2	nut	steel
0160	1	cleaning cover	cast iron	0860	1	spacer sleeve	bronze
0170*	1	suction valve	steel / rubber	2010	1	bearing bracket	cast iron
0380*	1	mechanial seal	BVGG	2100*	1	pump shaft	stainless steel
0410*	1	gasket for 0150	--	2110	2	bearing cover	steel
0420*	1	gasket for 0140	--	2120	1	washer	stainless steel
0430*	1	gasket for 0160	rubber	2300*	1	key	stainless steel
0440*	1	gasket for 0110	--	2310*	1	key	steel
0700	1	plug	forgeable cast iron	2320*	2	ball bearing	--
0701	1	plug	synthetic material	2330	2	inner circlip	spring steel
0710	2	plug	forgeable cast iron	2350	1	impeller nut	galvanised steel
0720	1	plug	forgeable cast iron	2360	2	filling ring	steel
0730*	1	lip seal	rubber	2370	1	deflector	rubber
0750	2	stud	steel	* recommended spare parts for normal use			
0760	2	nut	steel				

Important: When ordering spare parts, please state:
 a) Pump type and serial number (see name plate),
 b) Quantity, name and item number of desired parts (materials).

7.12 Parts list and sectional drawing KGE[®] Bearing bracket 2 KGE22-6

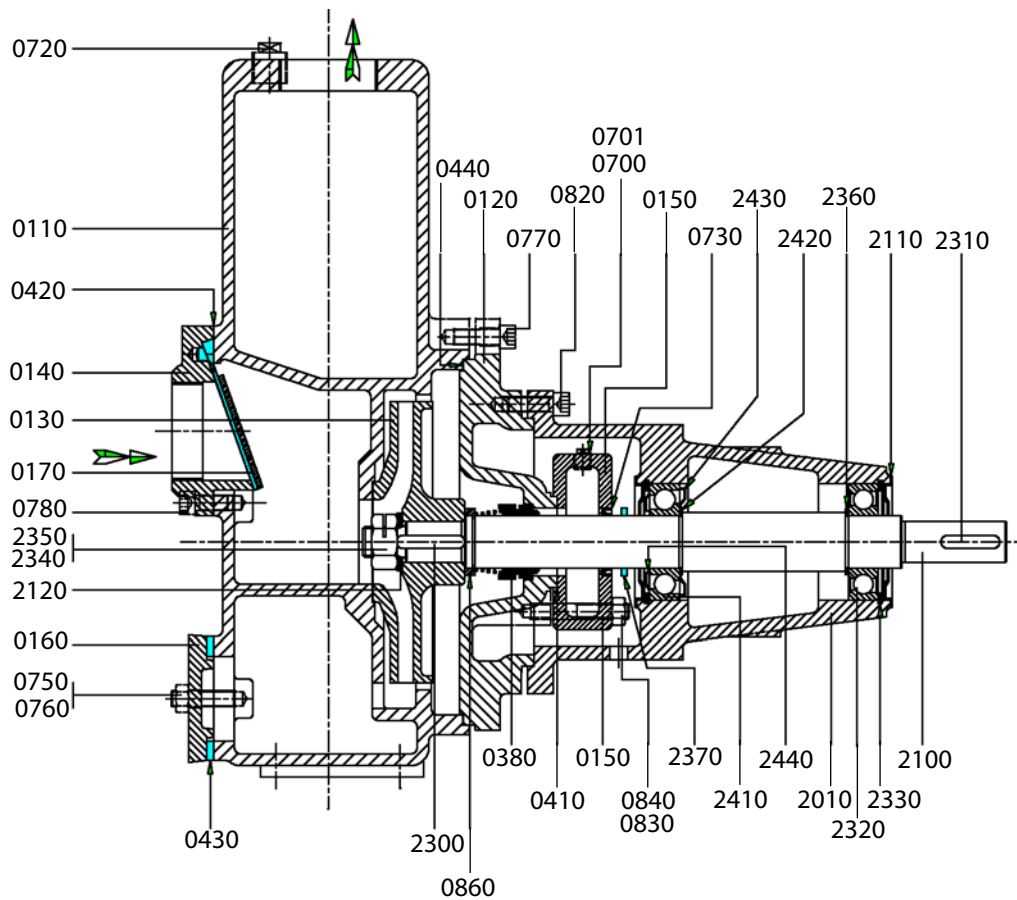

Fig 22

Item	Qty	Description	Material	Item	Qty	Description	Material
0110	1	pump casing	cast iron	0820	8	Allen screw	steel
0120	1	shaft seal cover	cast iron	0830	2	stud	steel
0130*	1	impeller	cast iron/ bronze	0840	2	nut	steel
0140	1	suction cover	cast iron	0860	1	spacer sleeve	bronze
0150	1	oil reservoir	cast iron	2010	1	bearing bracket	cast iron
0160	1	cleaning cover	cast iron	2100*	1	pump shaft	stainless steel
0170*	1	suction valve	steel / rubber	2110	2	bearing cover	steel
0380*	1	mechanical seal	BSVGG	2120	1	washer	stainless steel
0410*	1	gasket for 0150	--	2300*	1	key	stainless steel
0420*	1	gasket for 0140	--	2310*	1	key	steel
0430*	1	gasket for 0162	rubber	2320*	1	ball bearing	--
0440*	1	gasket for 0110	--	2330	2	inner circlip	spring steel
0700	1	plug	forgeable cast iron	2350	1	impeller nut	galvanised steel
0701	1	plug	synthetic material	2360	2	filling ring	steel
0720	1	plug	forgeable cast iron	2370	1	deflector	rubber
0730*	1	oil seal	rubber	2410*	1	angular contact bearing	--
0750	2	stud	steel	2420	1	filling ring	steel
0760	2	nut	steel	2430	1	nilos ring	steel
0770	12	Allen screw	steel	2440*	1	nilos ring	steel
0780	4	Allen screw	steel	* recommended spare parts for normal use			

Important: When ordering spare parts, please state:
 a) Pump type and serial number (see name plate),
 b) Quantity, name and item number of desired parts (materials).

7.13 Parts list and sectional drawing KGEF

Bearing bracket 00,0 and 0+ (①②②+)

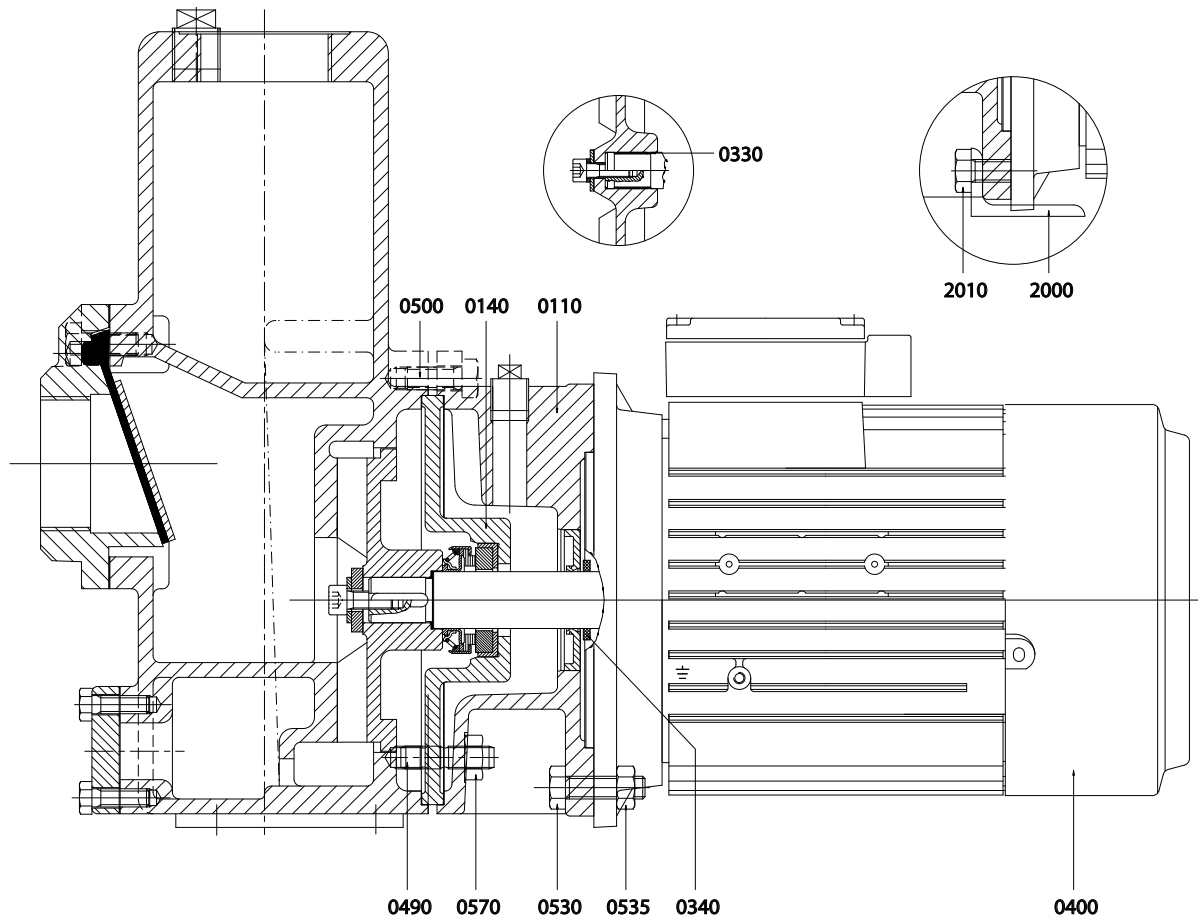

Fig 23

For general parts, see part list of basic KGE construction

Item	Spare part	Remark	Qty	Description	Material
0110			1	lantern piece	cast iron
0140			1	intermediate piece	cast iron
0330	*	(a)	1	tolerance ring	stainless steel
0340	*		1	deflector	rubber
0400			1	motor	steel
0490		(b)	2	stud	steel
0500			2(*)	tap bolt	steel
0530			4	tap bolt	steel
0535		(b) (d)	4	nut	steel
0570		(b)	2	nut	steel
2000		(c)	1	support	steel
2010		(c)	1	tap bolt	steel

(a) Only for KGEF11-3 and KGEF11-4

(b) Not for KGEF11-3 and KGEF11-4

(c) Only for KGEF14-8, KGEF15-6 and KGEF16-6

(d) Not for KGEF12-6

*) 4 pieces for KGEF11-3 and KGEF11-4

7.14 Parts list and sectional drawing KGEF③④

Bearing bracket 1 and 2

KGEF18-4 / KGEF20b-5

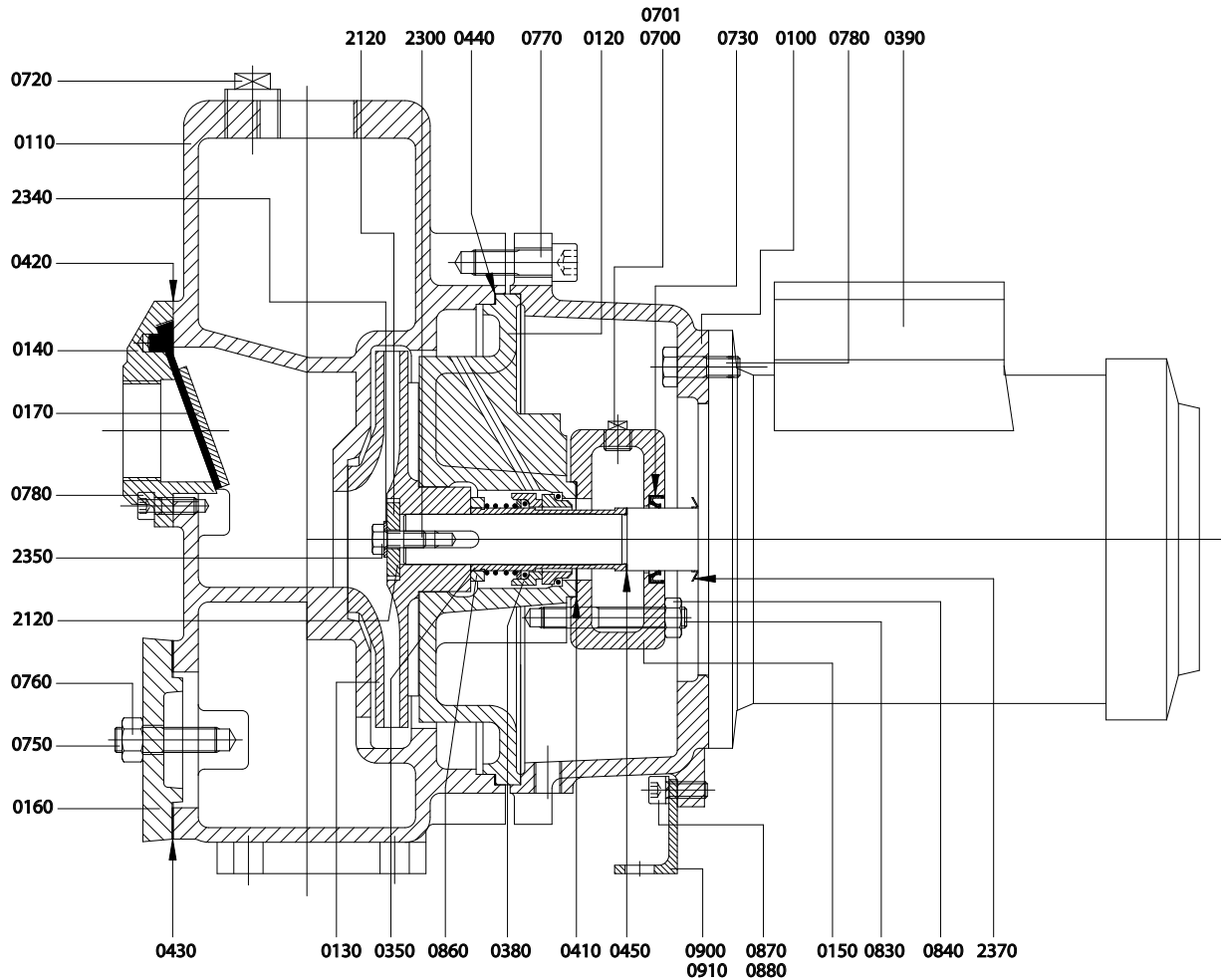

Fig 24

For general parts, see part list of basic construction

Item	Spare part	Remark	Qty	Description	Material
0100			1	lantern piece	cast iron
0350	*		1	shaft sleeve	bronze
0390			1	motor	--
0400			1	bracket support	steel
0450	*		1	gasket for 0350	--
0740			4	tap bolt	steel
0870			2	hex. bolt	steel
0880			2	spring washer	spring steel
2340			1	spring washer	stainless steel