



JOHNSON PUMP
AN SPX BRAND

FreFlow

Self-priming centrifugal pumps



FreFlow – Self-priming centrifugal pumps for various applications

SPX Process Equipment has many years experience in designing, manufacturing and maintaining self-priming centrifugal pumps for contaminated liquids. On the basis of this experience, the FreFlow pumps were developed to cover a broad field of applications. High priority has been given to the design ensuring easy operation and amazing reliability.

FreFlow pumps are self-priming centrifugal pumps suitable for handling contaminated and low-viscosity liquids. Its innovative design, eliminating the need for a non-return valve, results in less maintenance. The self-priming ability prevents the pump from running dry and ensures smooth and easy operation.

The basic pump is available in cast iron, bronze or stainless steel.

Thanks to its high-quality material, the stainless steel version is excellent for handling aggressive, corrosive and environmentally harmful liquids.

Typical industries are: chemical, petrochemical and pharmaceutical industry, oil, gas and electricity generation, paper, plastic, paint and metal finishing industry and shipbuilding.

The combination of its easy maintenance and operation, make the FreFlow a suitable pumping solution for a large number of applications.



Typical characteristics

- Excellent self-priming ability
- No non-return valve required in inlet
- Oil bath for the mechanical seal
- Ideal for handling contaminated liquids
- Outstanding qualities for liquids containing gas or air
- Easy maintenance (back pull-out)
- Easy operation
- Mechanical seals to EN 12756 (DIN 24960)

From know-how to finding solution



- Petrochemical
- Chemical
- Industrial Water
- General Industry
- Shipbuilding

The FreFlow has been designed to meet the customer's needs for handling contaminated liquids as well as liquids containing air or gas.

The compact design makes the FreFlow easy to handle, whilst its robust design ensures a life-long durability.

The FreFlow is frequently used on sumps or gullies where its high level of performance and self-priming ability ensure outstanding reliability in operation.

Thanks to its excellent self-priming characteristics, the FreFlow is a typical marine pump for example bilge and ballast pumping as well as for fire fighting.

The FreFlow is the sensible alternative to submersible pumps.

Features and *Benefits*

No non-return valve required in the inlet

- *Easy operation*
- *Less maintenance*

Excellent self-priming abilities

- *Ability to handle liquids containing air or gas*
- *A separate vacuum pump nor any other equipment is required*

Modular design

- *4 bearing bracket groups*
- *Fewer parts thanks to high interchangeability of parts within the range*
- *Rugged construction*

Different drive possibilities

- *Flexible operation*
- *Adaptable to your systems*

Inspection and cleaning cover

- *Easy maintenance and cleaning*

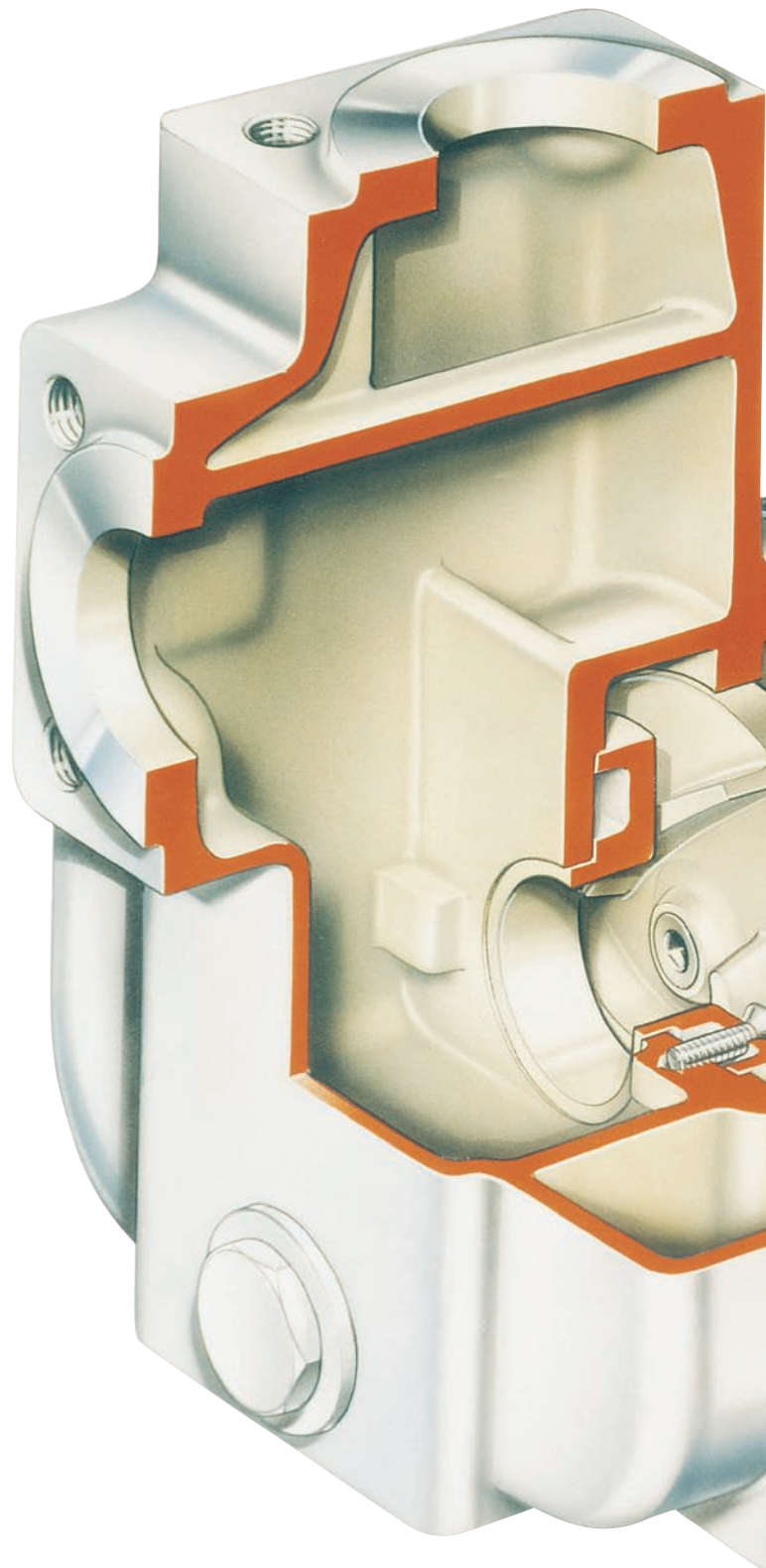

Various seal options

- Including double mechanical seals
- *Suitable for a variety of applications*

Wear plate

- Easily replaceable
- *Simple and inexpensive maintenance*
- *Extend pump life at maximum performance*

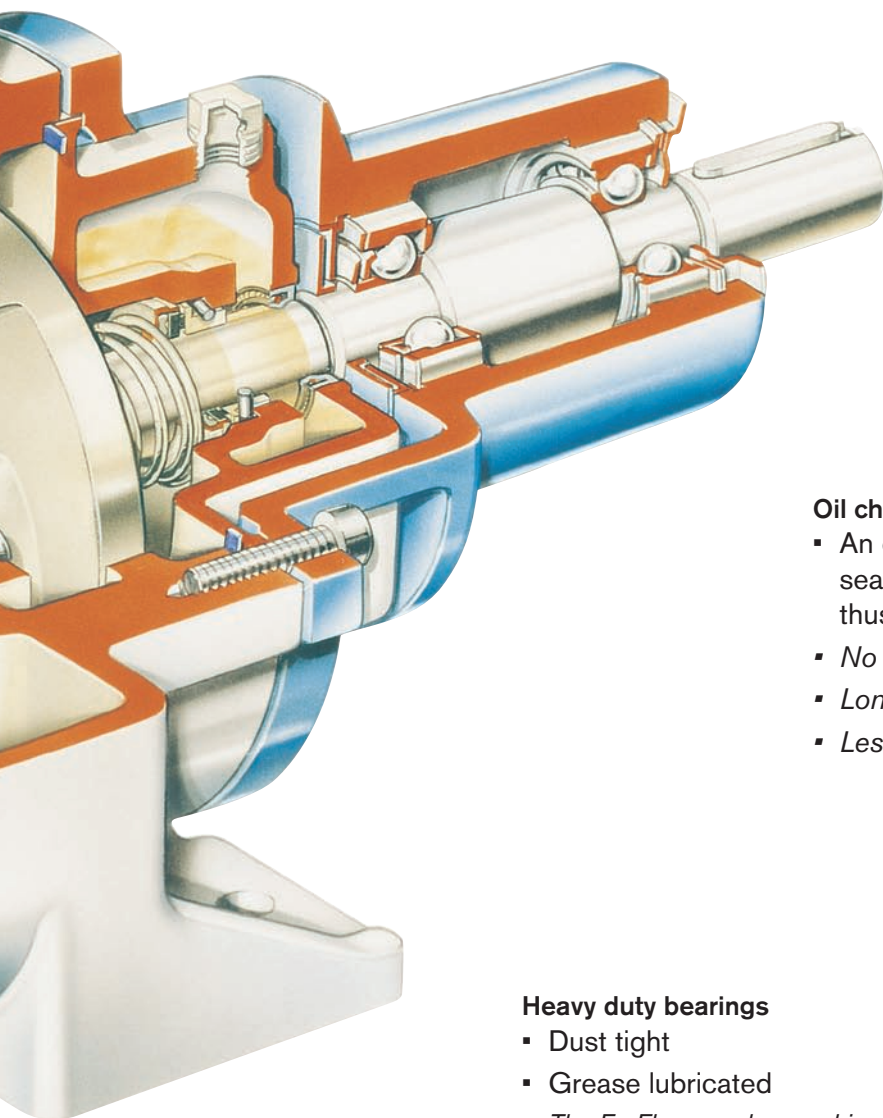

Back-Pull-Out system

- *Easy maintenance*
- *No need to remove from pipework*

Oil chamber

- An oil chamber located behind the mechanical seal lubricates the seal faces when priming – thus preventing the seal from running dry
- *No crystallization between the seal faces*
- *Longer seal life*
- *Less risk of process downtime*

Heavy duty bearings

- Dust tight
- Grease lubricated
- *The FreFlow can be used in a dusty and dirty environment*
- *Longer mean-time between failure*

Technical data

The FreFlow range consists of 20 pumps with connections from 32 mm to 150 mm, with a capacity of up to 300 m³/h and a delivery head of up to 70 meters. The self-priming ability is 7 meters. The maximum system pressure is 9 bar and the pumps can transport liquids with a viscosity of max 150 mPa.s. The pumps in the FreFlow programme offer flexible operation thanks to the different drive possibilities.



FRE
 Pumps with bearing bracket



FREF
 Pumps coupled to a flange motor on extended shaft



FRES
 Pumps coupled to IEC standard motor



FREM
 Pumps coupled to a petrol or diesel engine

Performance overview

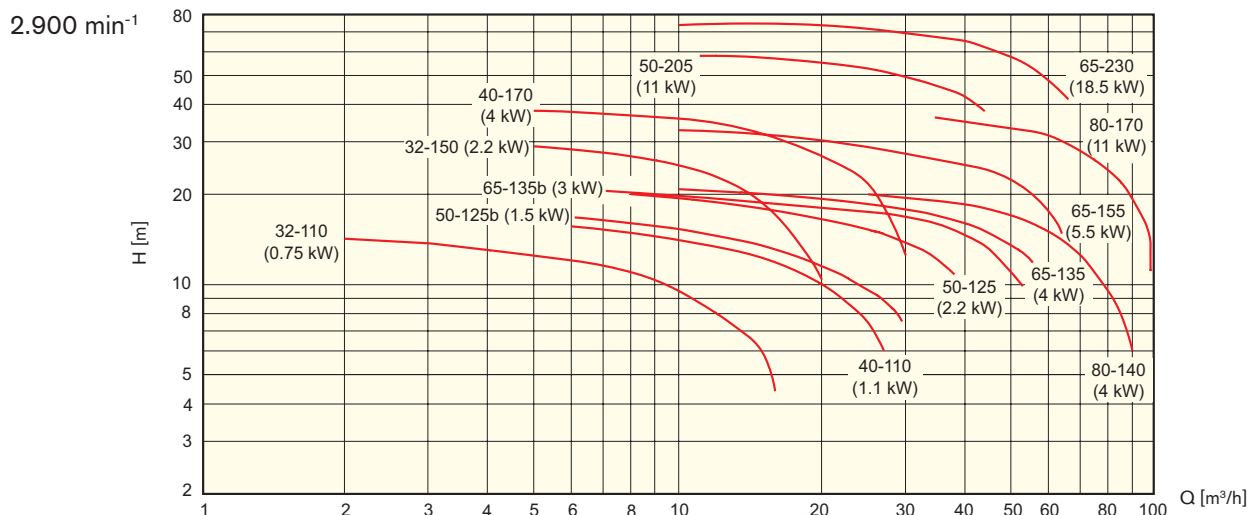
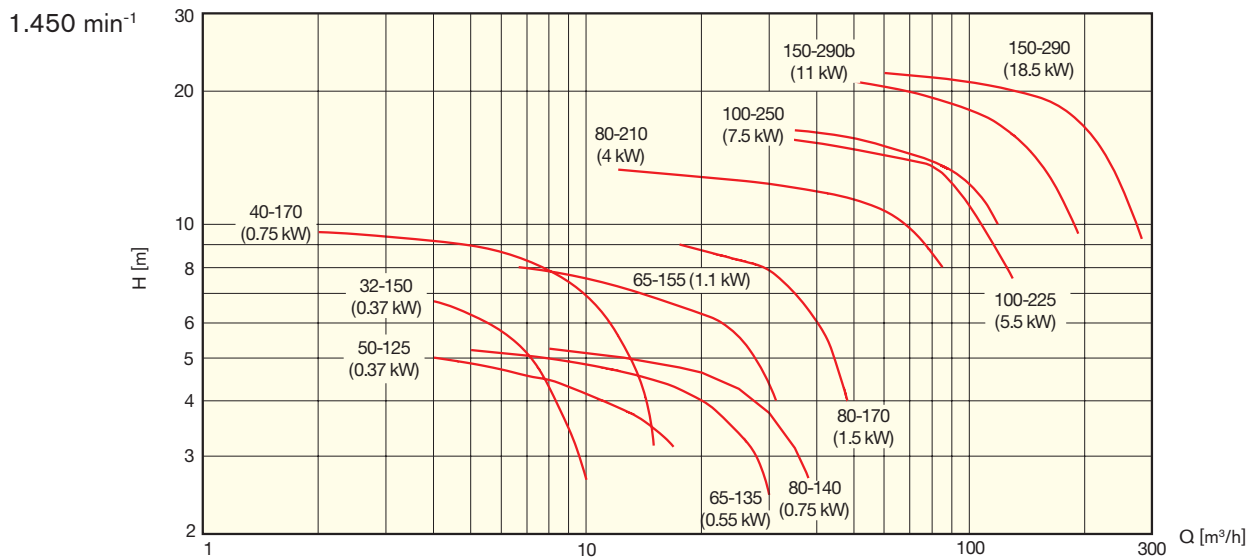

Operating principle

The self-priming operation of the FreFlow is based on the injection principle.

On start-up the air in the suction pipe is drawn into the pump, with the air and liquid mixture being compressed in the pump. This mixture flows to the top of the pump casing where the air separates from the liquid and is removed through the discharge pipe. The liquid recirculates in the pump casing until all air is evacuated from the suction pipe. The pump functions thereafter as a conventional centrifugal pump.

Before first start-up, the pump casing must be filled once with liquid. The special design prevents the pump emptying after it has stopped pumping. In that way there is enough liquid in the pump for the next start-up.

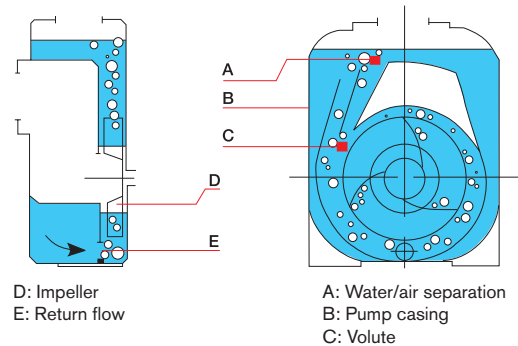

Dimensions and weights

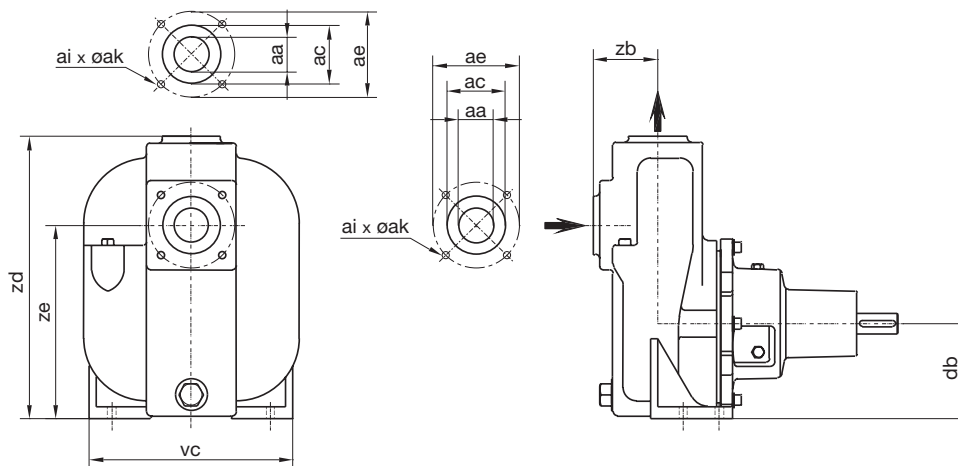

Model	aa	ac	ae	ai	ak	db	vc	zb	zd	ze	Weight, kg		
											FRE	FRES	FREM
32-110	BSP 1.1/4"	-	-	-	-	80	228	73	270	185	20	30	31
32-150	BSP 1.1/4"	-	-	-	-	100	240	73	300	205	30	50	43
40-110	BSP 1.1/2"	-	-	-	-	80	228	78	275	190	22	38	32
40-170	BSP 1.1/2"	-	-	-	-	160	292	78	395	285	60	90	-
50-125	BSP 2"	100	125	4	M16	100	260	100	330	220	40	60	50
50-125b	BSP 2"	100	125	4	M16	100	260	100	330	220	40	60	50
50-205	BSP 2"	100	125	4	M16	160	310	105	440	300	80	140	-
65-135	65 mm	120	145	4	M16	112	260	107	365	252	45	75	62
65-135b	65 mm	120	145	4	M16	112	260	107	365	252	45	65	52
65-155	65 mm	120	145	4	M16	132	292	107	395	282	52	105	92
65-160	65 mm	120	145	4	M16	162	292	107	395	282	41	94	81
65-230	65 mm	120	145	4	M16	160	356	114	475	325	90	215	-
80-140	80 mm	135	160	8	M16	132	292	126	410	282	62	90	76
80-170	80 mm	135	160	8	M16	160	360	126	470	340	100	210	-
80-210	80 mm	138	160	8	M16	220	400	130	620	480	130	-	-
100-225	100 mm	155	180	8	M16	200	440	156	595	430	145	200	-
100-225b	100 mm	155	180	8	M16	200	440	156	595	430	145	200	-
100-250	100 mm	158	180	8	M16	280	400	145	730	590	150	-	-
150-290	150 mm	212	240	8	M20	250	490	185	715	540	270	-	-
150-290b	150 mm	212	240	8	M20	250	490	185	715	540	270	-	-