



**JOHNSON PUMP**  
AN SPX BRAND

# CombiMag / Bloc

## Magnetic Drive Centrifugal Pumps



**SPX**<sup>®</sup>

# Safe and Leak-Proof Design

CombiMag and CombiMagBloc represent a range of leak-proof pumps for applications which convey corrosive, toxic, aggressive or expensive liquids.

Total containment of the liquid inside the pump is achieved using a hermetically sealed can, which isolates the liquid from the surrounding environment. This eliminates the need for mechanical seals and the associated wear and leakage that would normally be experienced with pumps which incorporate mechanical seal design. The Magnetic Drive pumps are therefore not only environmentally friendly – they also contribute to improved safety in chemical and process plant environments.

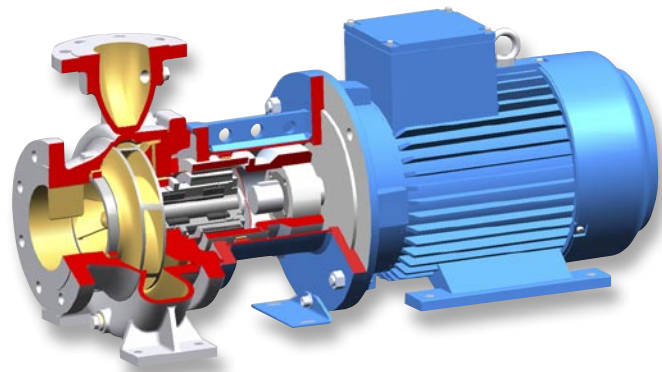
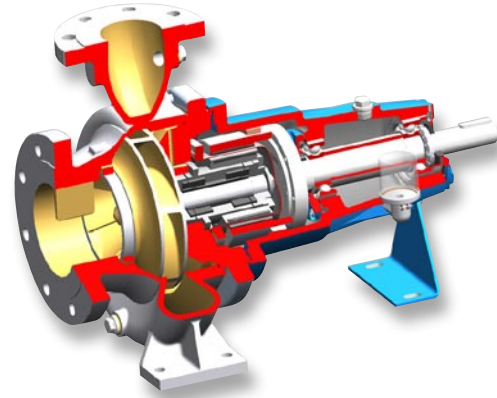

	<b>CombiMag</b>	<b>CombiMagBloc</b>
Standard	ISO 5199, ISO2558 / EN 22858	ISO 5199, ISO2558 / EN 22858
Design	Frame mounted long coupled design	Close coupled design
Capacity	up to 500 m <sup>3</sup> /h	up to 280 m <sup>3</sup> /h
Head	up to 160 m	up to 140 m
Max. system pressure	1600 kPa (16 bar), 2500 kPa (25 bar) optional	1600 kPa (16 bar), 2500 kPa (25 bar) optional
Temperature	-50 °C up to 300 °C, 350 °C optional	-50 °C up to 200 °C
Min. viscosity	0,3 mPas	0,3 mPas
Max. viscosity	150 mPas	150 mPas
Slurry	Maximum 5% weight, size maximum 250 µm	Maximum 5% weight, size maximum 250 µm
Solids	Maximum diameter 0.1 mm, hardness 700 HV	Maximum diameter 0.1 mm, hardness 700 HV
Magnets	Samarium Cobalt (SmCo)	Samarium Cobalt (SmCo)
Plain bearings	Silicon Carbide (SiC)	Silicon Carbide (SiC)
Can	"Hastelloy C4®"	"Hastelloy C4®"
Inner rotor	Duplex / "Hastelloy C4®"	Duplex / "Hastelloy C4®"
Max. power at 3000 rpm	75 kW	45 kW
Motor frame size range	IEC 80 - 280S/M	IEC 80 - 112M IM3001 (B5) IEC 132S/M - 225S/M IM2001 (B3/B5)
Available materials	Stainless Steel, Nodular Cast Iron, Cast Iron, Duplex, Alloy 20, Hastelloy C®	Stainless Steel, Nodular Cast Iron, Cast Iron, Duplex, Alloy 20, Hastelloy C®

# Versatile Application Range

## Combi Concept

- Very easy upgrading of mechanically sealed pumps to hermetically sealed magnetic drive pumps
- Interchangeability of Back-Pull-Out units with CombiChem, CombiNorm, CombiPro
-  ATEX certified applications
- Extended MTBF (Mean Time Between Failure)
- Reduced repair costs

## Easy Maintenance

- Contained Back-Pull-Out, the pump cover with containment can remain bolted to the pump casing for drive end maintenance
- Pump does not need to be drained
- System remains pressurised
- Simple assembly through optimized design

## Applications

- Solvents
- Acids
- Alkalis
- Volatile organic chemicals
- Hydrocarbons
- Hot process liquids
- Heat transfer oils
- Toxic liquids
- Corrosive liquids
- Heating water

## Advantages

- Zero leakage
- Easy maintenance
- Ensures clean, safe and leak-free operating environment
- High degree of parts compatibility
- Short delivery times
- Total product containment

## Industrial Segments

- Chemical industry
- Pharmaceutical industry
- Petrochemical industry, refineries
- Water treatment
- Metal processing
- Recycling industry
- Refrigeration
- Heating
- Tank storage

# Performance Curves

only CMB types

CM and CMB types

only CM types

3000 rpm

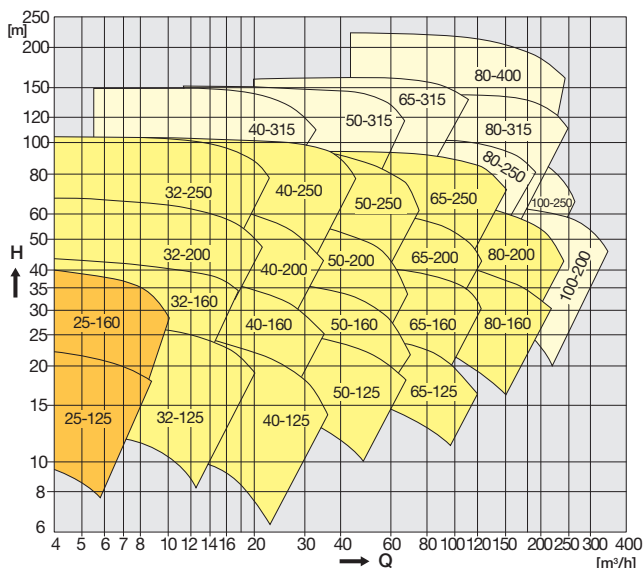

1500 rpm

