

CombiLine

In-line circulation pump

CombiLine range extended with 8 new versions



Reliable temperature control in the greenhouse is crucial for the optimal running of your process. The performance of your circulation pumps is of paramount importance to this process. Therefore your business relies on your circulation pumps.

The CombiLine is by far the most suitable pump for both heating and cooling systems. The CombiLine in-line circulation pump offers optimal efficiency and the highest reliability.

The CombiLine's specially designed suction bend, the improved impeller design and the ample hydraulic application range guarantee an excellent hydraulic performance.

These 8 new versions contribute to a significant extension of the hydraulic application range.

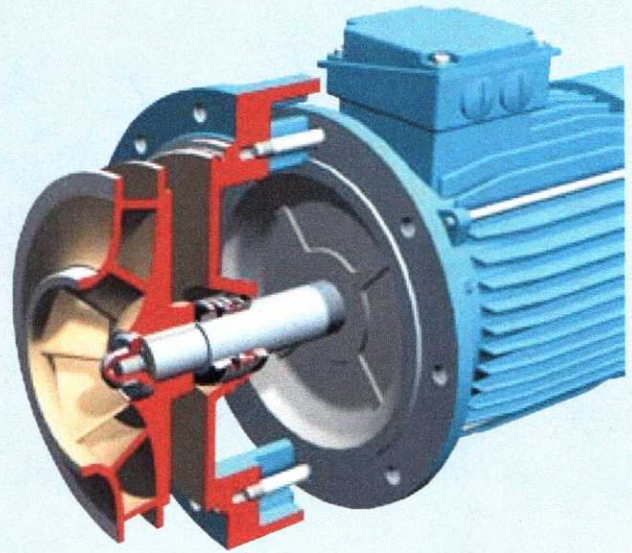

The CombiLine build-in in-line circulation pump is fitted with an IEC flange motor with extended motor shaft. The impeller is mounted directly onto the extended motor shaft. The pump is fitted with a rubber bellows mechanical seal, according to EN 12756 (DIN 24960).

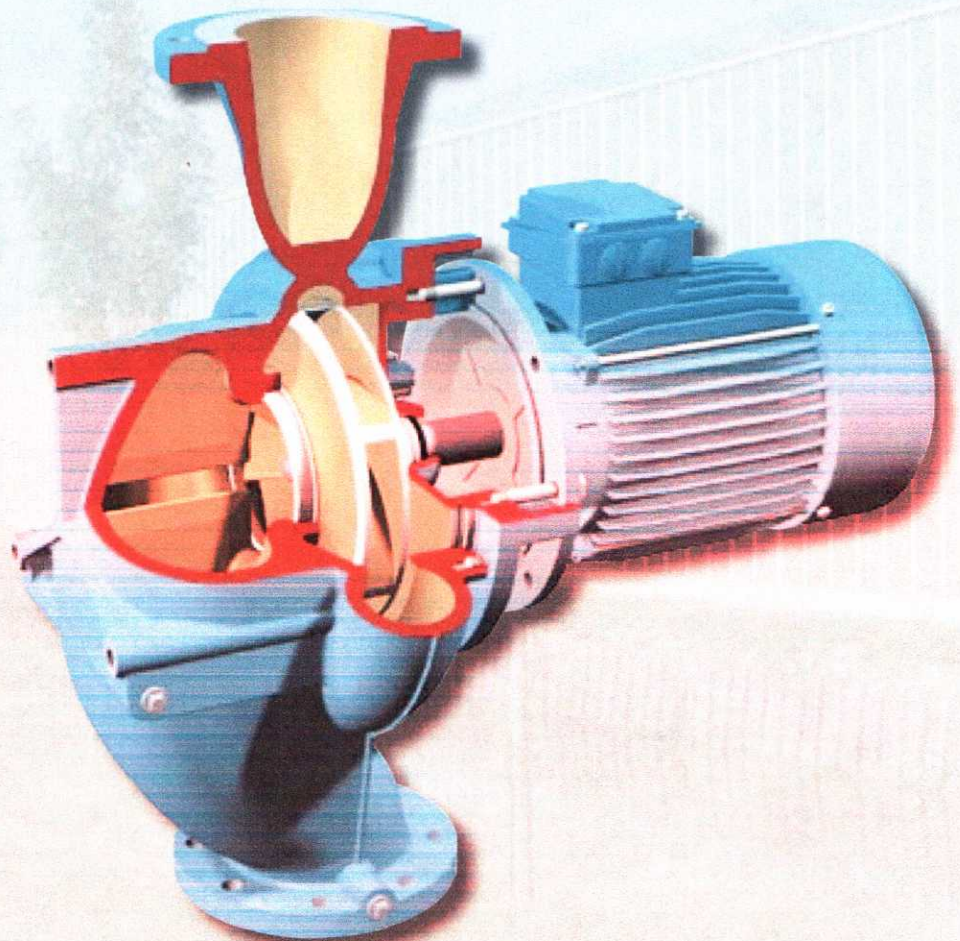

Pump curves

All the curves shown here, unless stated otherwise, are based upon standard speeds for 4-pole electric motors at 50 Hz and refer to water with a temperature of 20 °C.

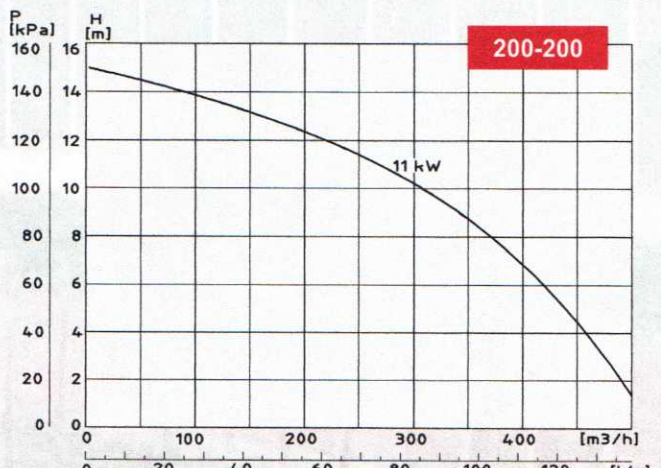
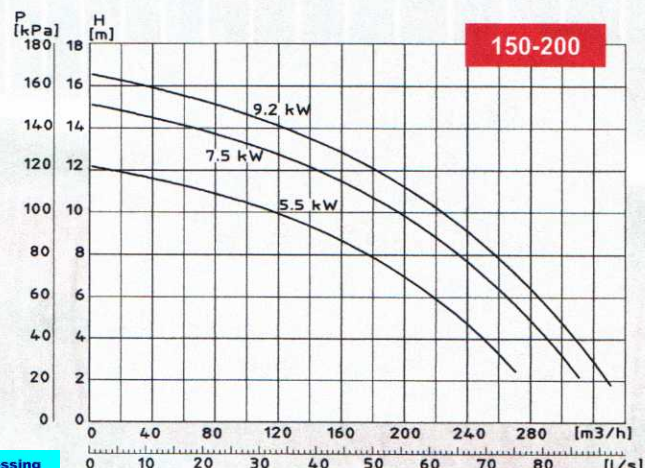
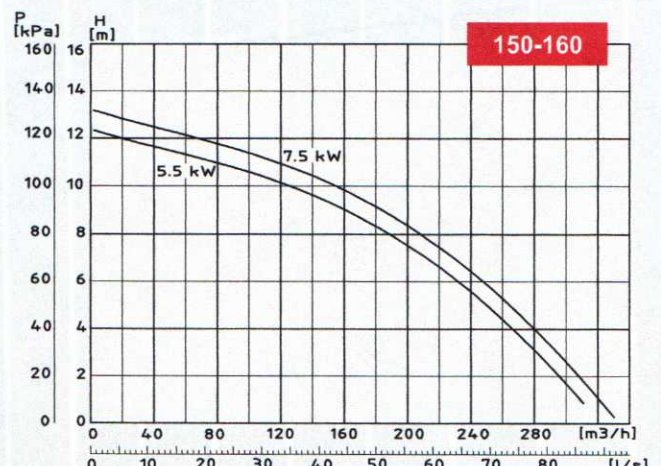
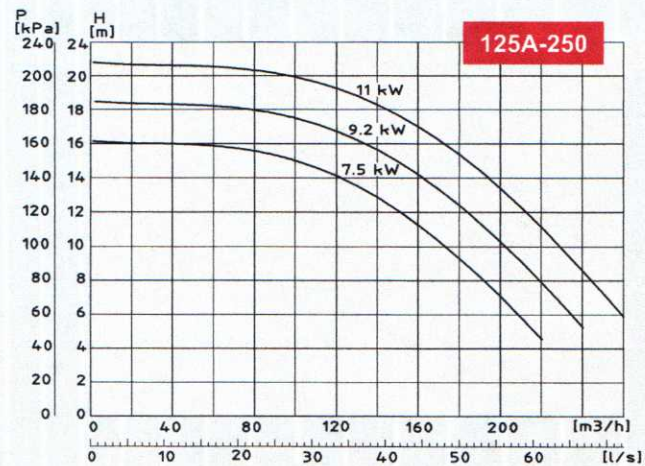
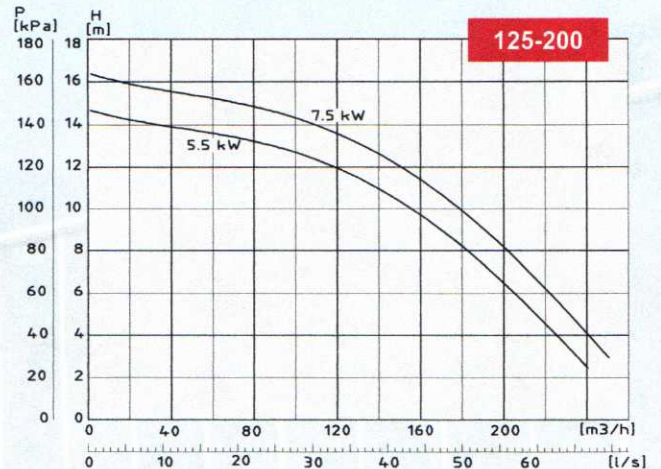
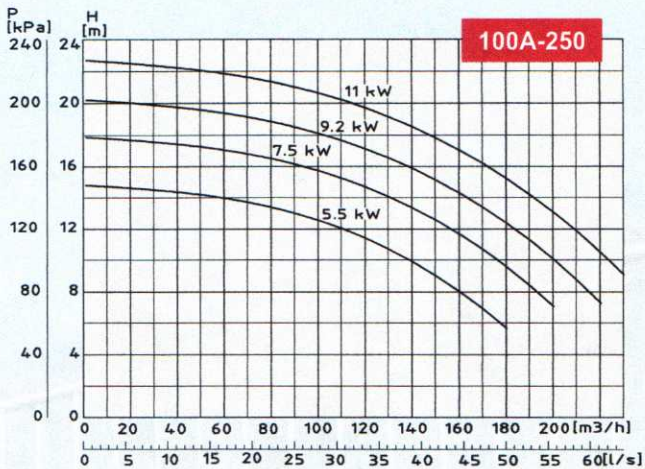
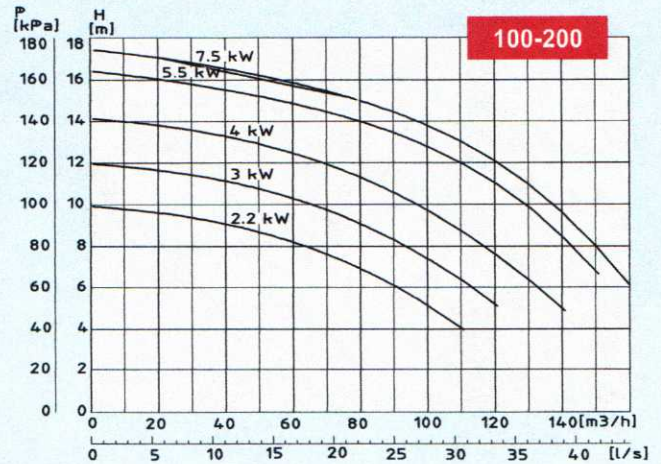
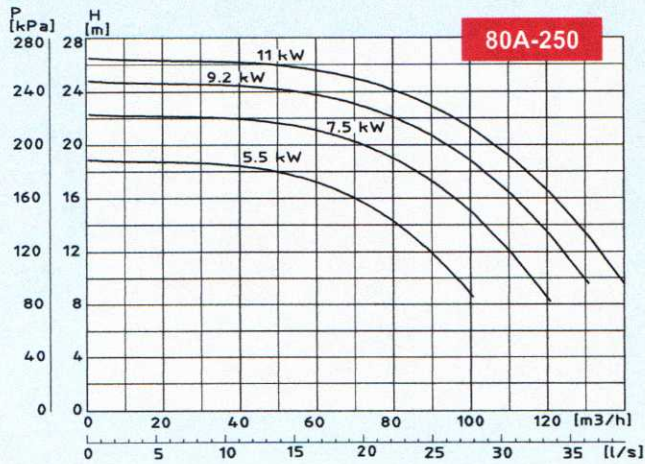

Dimensions

Flanges ND10 according to EN 1092-2 PN10 (DIN 2532 / ≈ ISO 7005 PN10)

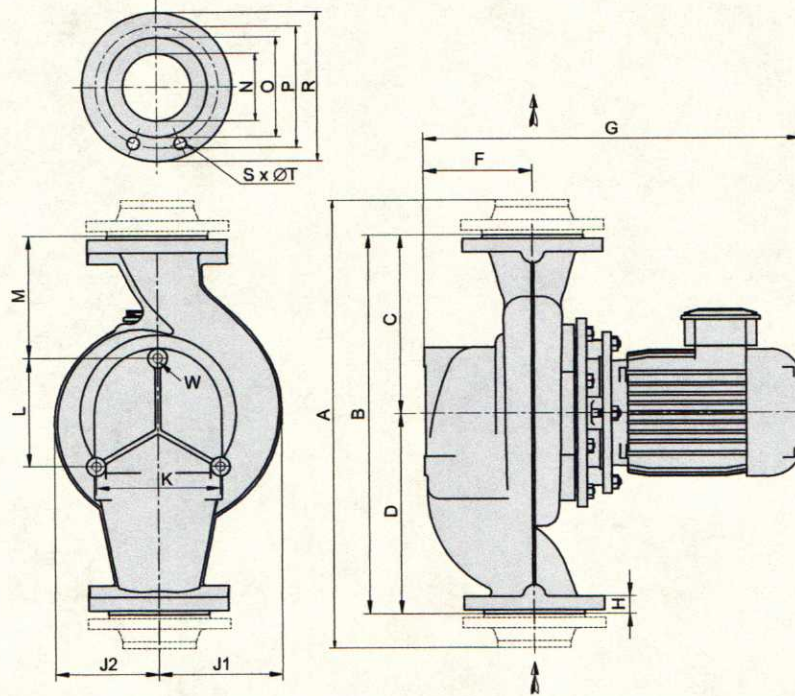

CL	A	B	C	D	F	H	J1	J2	K	L	M	N	W
80A-250	700	590	280	310	214,5	27	200	176	195	169	175	100	M16
100-200	700	590	280	310	171	27	195	163	195	169	192,5	100	M16
100A-250	846	730	355	375	224,5	28,5	237	202	225	195	241	125	M16
125-200	866	750	375	375	247	26	223	178	225	195	280	125	M16
125A-250	921	805	355	450	282,5	28,5	261	216	310	254	212	150	M16
150-160	866	750	315	435	287	28,5	257	200	310	230	175	150	M20
150-200	836	720	315	405	245	24,5	245	198	258	198,5	214	150	M20
200-200	1030	900	400	500	337	26,5	297	237	298	230,5	280	200	M20

CL	G						
	2,2 kW	3 kW	4 kW	5,5 kW	7,5 kW	9,2 kW	11 kW
80A-250				733	771	788	788
100-200	593	593	612	684	722		
100A-250				747	785	802	802
125-200				768	806		
125A-250					843	860	860
150-160				818	856		
150-200				775	813	830	
200-200							926

N	O	P	R	S*T
100	158	180	220	8*18
125	188	210	250	8*18
150	212	240	285	8*18
200	268	295	340	8*22



JOHNSON PUMP

Johnson Pump Horticulture