

CombiChem

Horizontal centrifugal pump to DIN 24256 (ISO 2858)



System characteristics

The CombiChem is a part of the CombiSystem, a family of different pump types having a high interchangeability in parts.

The CombiChem, designed to DIN 24256 (ISO 2858), offers a great variety of possible shaft sealings, bearing constructions and also a wide range of different material executions, such as stainless steel, bronze, nodular cast iron or cast iron. The construction of the CombiChem complies entirely with ISO 5199. This means a high operational reliability, providing long servicing intervals

Applications

The CombiChem is suitable for handling low viscosity, clean or slightly contaminated liquids, especially in the chemical industry.

Pump specifics

- Suitable for a wide range of duties
- Fully satisfies the requirements of ISO 5199
- The bearing pedestals are threaded in two places to allow the use of jacking screws
- Flanges according to ISO 7005 PN 16, for stainless steel execution 150 lbs ANSI B 16.5 available
- Simple maintenance thanks to the use of standard components and the Back-Pull-Out principle applied
- Flexible choice in bearings and shaft seal modules
- The entire pump family features only three bearing bracket groups

Technical data

Maximum capacity:	350 m ³ /h
Maximum delivery head:	160 m
Maximum liquid temperature:	200°C
Maximum operating pressure:	16 bar (1600 kPa)
Maximum speed:	3600 rpm

Materials

Pump casing	Cast iron	Nodular cast iron	Bronze	Stainless steel
Impeller	Cast iron	Bronze	Stainless steel	
Pump shaft	Alloy steel (X22CrNi17)	Stainless steel (X2CrNiMo 18.10)		
Shaft sleeve	Stainless steel	Bronze	Alloy steel	
Pump cover	Cast iron	Nodular cast iron	Bronze	Stainless steel
Bearing bracket	Cast iron			
Wear ring	Cast iron	Bronze	Stainless steel	

Other materials on request

Performance data

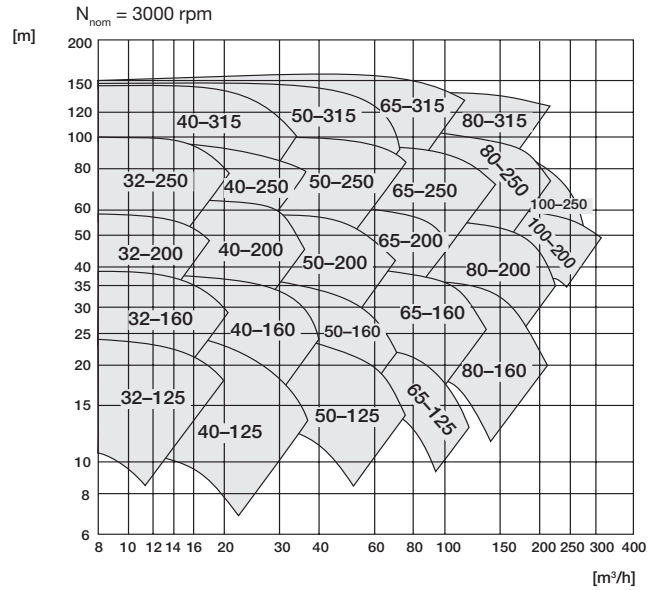
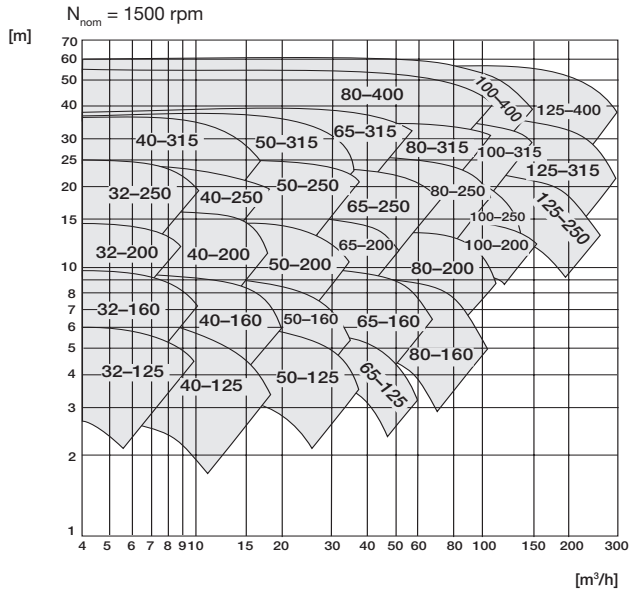

Dimensions

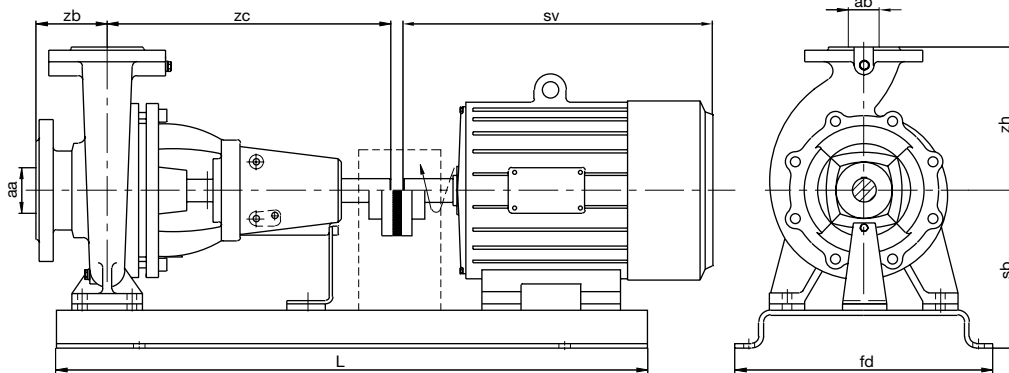

Combi Chem	ISO 7005 PN 16		zb	zh	sb	fd	zc	L
	aa	ab						
32-125	50	32	80	140	162	433	385	800
32-160	50	32	80	160	182	433	385	800
32-200	50	32	80	180	210-228	433-473	385	800-1000
32-250	50	32	100	225	230-285	433-545	500	800-1250
40-125	65	40	80	140	162	433	385	800
40-160	65	40	80	160	182-228	433-473	385	800-1000
40-200	65	40	100	180	210-228	433-473	385	800-1000
40-250	65	40	100	225	230-285	433-545	500	800-1250
40-315	65	40	125	250	268-415	473-748	500	1000-1600
50-125	80	50	100	160	182-228	433-473	385	800-1000
50-160	80	50	100	180	210-228	433-473	385	800-1000
50-200	80	50	100	200	210-285	433-545	385	800-1250
50-250	80	50	125	225	230-320	433-658	500	800-1250
50-315	80	50	125	280	293-415	473-748	500	1000-1600
65-125	100	65	100	180	210-228	433-473	385	800-1000
65-160	100	65	100	200	210-285	433-545	500	800-1250

Combi Chem	ISO 7005 PN 16		zb	zh	sb	fd	zc	L
	aa	ab						
65-200	100	65	100	225	230-285	433-545	500	800-1250
65-250	100	65	125	250	268-320	473-658	500	1000-1250
65-315	100	65	125	280	310-415	545-748	530	1250-1600
80-160	125	80	125	225	230-285	433-545	500	800-1250
80-200	125	80	125	250	248-415	473-748	500	1000-1600
80-250	125	80	125	280	310-415	545-748	500	1250-1600
80-315	125	80	125	315	335-415	545-748	530	1250-1600
80-400	125	80	125	355	375	658	530	1250
100-200	125	100	125	280	268-415	473-748	500	1000-1600
100-250	125	100	140	280	310-415	545-748	530	1250-1600
100-315	125	100	140	315	335-415	545-748	530	1250-1600
100-400	125	100	140	355	375-385	658	530	1250-1600
125-250	150	125	140	355	335	545	530	1250
125-315	150	125	140	355	375-385	658	530	1250-1600
125-400	150	125	140	400	410-450	658-748	530	1250-1600

sv: depending on motor-frame size. ISO 7005 PN16 ≈ DIN 2533



Johnson Pump B.V.

