



JOHNSON PUMP
AN SPX BRAND

CombiChem Centrifugal pumps

according to ISO 5199 and ISO 2858 / EN 22858 (DIN 24256)



Packaging - Processing
Bid on Equipment
1-847-683-7720
www.bid-on-equipment.com

SPX[®]

CombiChem – No limits to reliability!

CombiChem is Johnson Pump's solution for liquid transport in the chemical industry. It is one of the most outstanding pump types of the Johnson Pump Combi-system. The Combi-system is a modular programme of single stage centrifugal pumps with a high degree of interchangeability of parts between the different pump constructions.

CombiChem represents a range of horizontal centrifugal pumps, designed to ISO 2858 / EN 22858 (DIN 24256), suitable for handling low viscosity, clean or slightly contaminated liquids.

The design of CombiChem complies entirely to ISO 5199. The CombiChem offers a great variety of possible shaft sealings, bearing constructions and also a wide range of different materials, such as stainless steel, bronze, nodular cast iron or cast iron.

A leakfree version of the CombiChem is the **CombiMag**, a magnetic coupled centrifugal pump, especially developed for the chemical industry.



CombiChem



Features

- Suitable for a wide range of duties
- Available in several materials
- Only 4 bearing brackets for the whole range
- Mechanical seals according to EN 12756 (DIN 24960)
- Single and double cartridge seals
- Back Pull Out principle

From know-how to finding solutions

■ Chemical Industry

The CombiChem is, as the name says, perfectly suited for operation in chemical industries. The pump has been designed entirely according to ISO 5199. The ISO 5199 standard defines important technical details of centrifugal pumps according to ISO 2858/EN 22858 (DIN 24256), used in chemical industries.



■ General Industry

CombiChem's availability in several materials, the ample choice of shaft sealing options and the rigid bearing construction makes it a very reliable pump for general industrial purposes. Complying to ISO 2858, ISO 5199 and EN 22858 (DIN 24256): CombiChem offers you the best solution.



Features and *benefits*

Suction capabilities

- smooth suction entry in pump casing
- smooth surface
- optimum NPSH
- anti rotation vane
- minimal flow distortion giving better suction capabilities

Impeller

- closed impeller with casing wear ring
- half-open impeller with wear plate

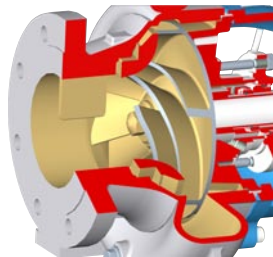

Pump casing

- flanges according to ISO 7005 PN 16 or ISO 7005 PN 20 (ANSI B16.5 150 lbs)
- max. working pressure 16 bar
- wide range of applications
- large drain opening
- complete and fast draining of the casing

Impeller locking

- stainless steel impeller cap nut with flat gasket
- reliable locking

Material options

- available in cast iron, nodular cast iron, bronze and stainless steel and other materials, such as duplex, upon request
- suitable for a wide range of applications

Impeller back vanes

- flat cover for hydraulic balancing
- back vanes for hydraulic balancing
- extended bearing life
- keeps solids away from shaft sealing area
- circulation flow over mechanical seal

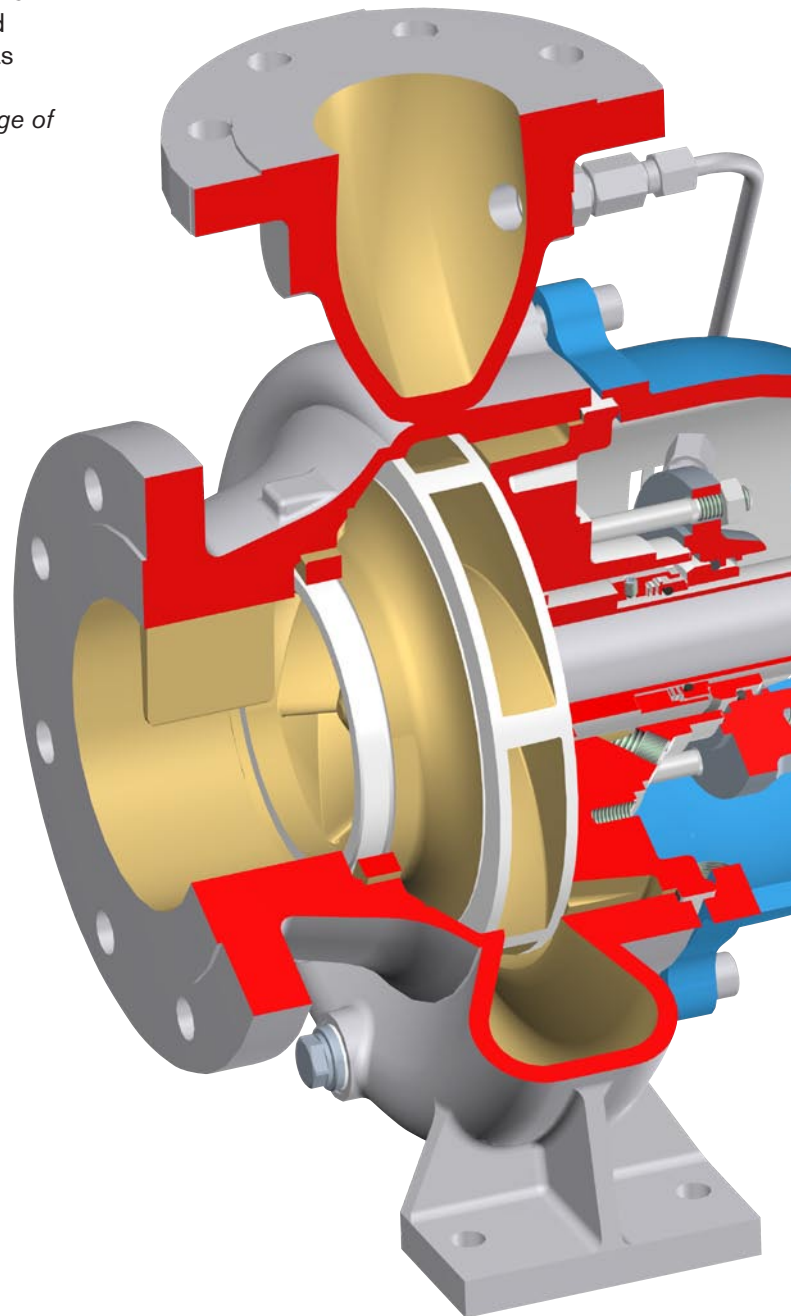

Foot

- machined foot
- exact positioning on baseplate and in pipework

Shaft

- stainless steel or steel alloy
- shaft deflection local to the shaft seal stays within 0,05 mm
- *prolonged seal life*
- *rigid, reliable shaft*
- shaft sleeve (extended impeller key ensures co-rotation of the shaft)
- *'dry' shaft: no contact between shaft and pumped liquid*

Shaft sealing

- 7 possible mechanical EN-seal, plus cartridge seal options
- sealing rings and elastomers in several possible combinations
- sealing cover with quench and flush connections
- 3 possible gland packing options e.g. with cooling cover
- *suitable for many applications*
- *suitable for many liquids*
- *also suitable for high temperatures*

Oil lubrication

- breather / filling plug on top
- oil bath
- oil sight glass
- constant level oiler
- large drain plug

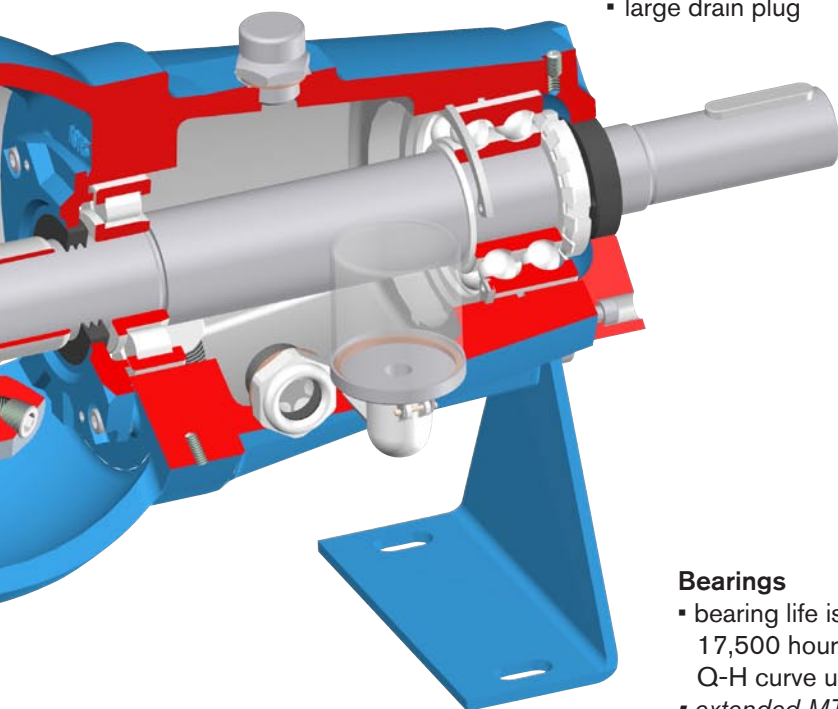

Pump cover

- flat gasket, fully chambered
- *no gasket blow-out*
- machined fits
- *perfect alignment of all components*
- integrated stuffing box/ mechanical seal chamber
- *fewer parts*

Bearings

- bearing life is at least 17,500 hours for the entire Q-H curve up to $1.25 Q_{BEP}$
- *extended MTBF*
- oil bath lubricated or grease lubrication
- bearing lock-up by means of shaft nut with lock washer
- *very reliable bearing lock-up*
- rigid cast iron bearing bracket construction
- *minimum bearing movement*
- machined fits
- *exact alignment*
- adjustable bearings
- *clearances for half-open impeller and wear plate can be adjusted*

Forces and moments

- the permissible forces and moments comply with the curves represented in ISO 5199

Pump performance

- optimised volute design
- *high efficiency*
- smooth surfaces
- *minimal internal losses*
- closed impeller, half-open impeller with wear plate
- *wide variety of applications*

Easy and low cost maintenance

- Back Pull Out principle
- *reduced maintenance downtimes, quick and easy impeller replacement*
- all gland packing options with shaft sleeve
- *no shaft damage from packing*
- mechanical seals according to EN 12756 (DIN 24960)
- *reduced maintenance costs*
- changeable wear ring
- *reduced maintenance costs*

Shaft sealings

CombiChem has a great variety of possible shaft sealing options: mechanical seals as well as stuffing box packing. All configurations are equipped with shaft sleeve, so the pump shaft never comes into contact with the pumped liquid. The following shaft sealing configurations are available:



Mechanical seal options:

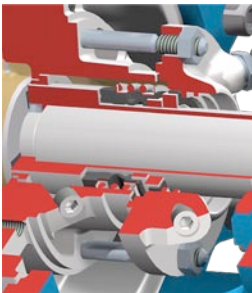

M2 MG12 / M7N
 single mechanical seal
 unbalanced

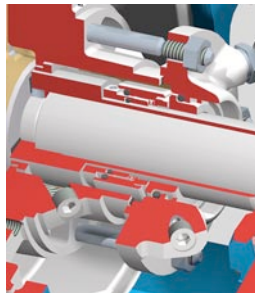

M3 HJ92N / HJ977GN
 single mechanical seal
 balanced

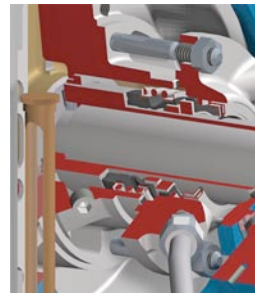

MQ2 MG12 / M7N
 single mechanical seal,
 dry-running protection
 or pressure-less quench,
 unbalanced

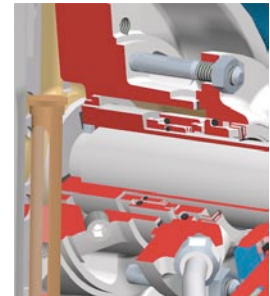

MQ3 HJ92N / HJ977GN
 single mechanical seal,
 dry-running protection or pressure-
 less quench, balanced

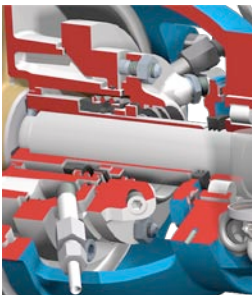

MW2 MG12 / M7N
 single mechanical seal,
 cooling/heating jacket,
 unbalanced

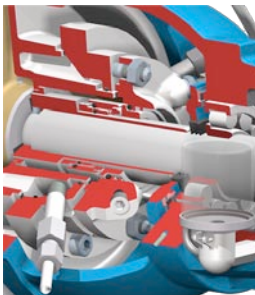

MW3 HJ92N / HJ977GN
 single mechanical seal,
 cooling/heating jacket,
 balanced

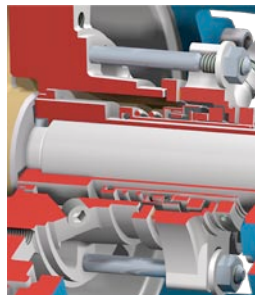

Cartridge seals
 single, single with quench
 and double cartridge seals

Gland packing options:

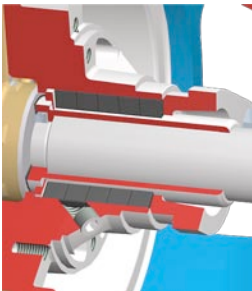

S2
 stuffing box with shaft
 sleeve

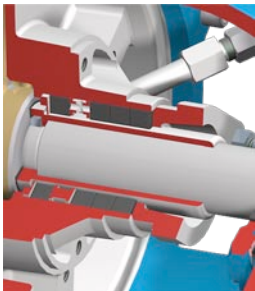

S3
 stuffing box with shaft
 sleeve and lantern ring

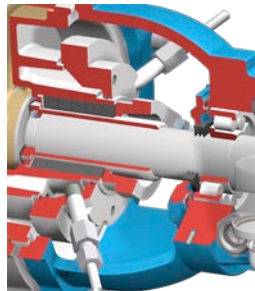

S4
 stuffing box with shaft
 sleeve, and cooling cover

Technical data

Max. capacity	800 m ³ /h
Max. head	160 m
Max. working pressure	1600 kPa (16 bar)
Temperature range	-50°C up to 200°C
Max. speed	3600 rpm

Hydraulic performance data

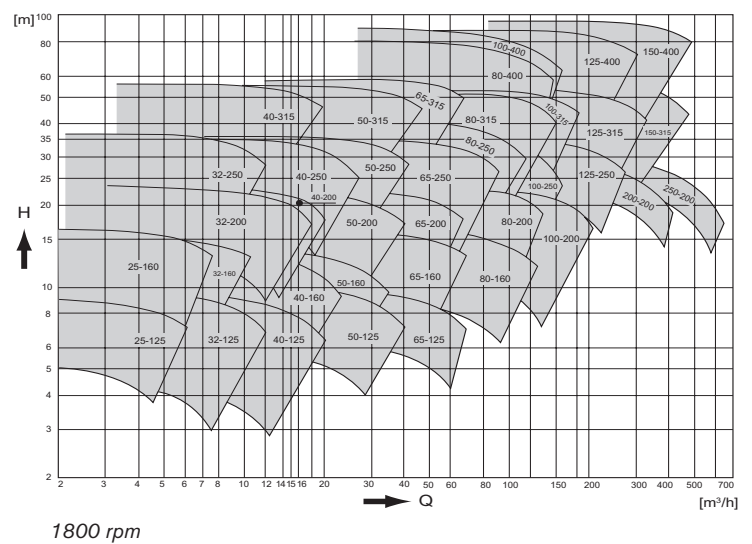
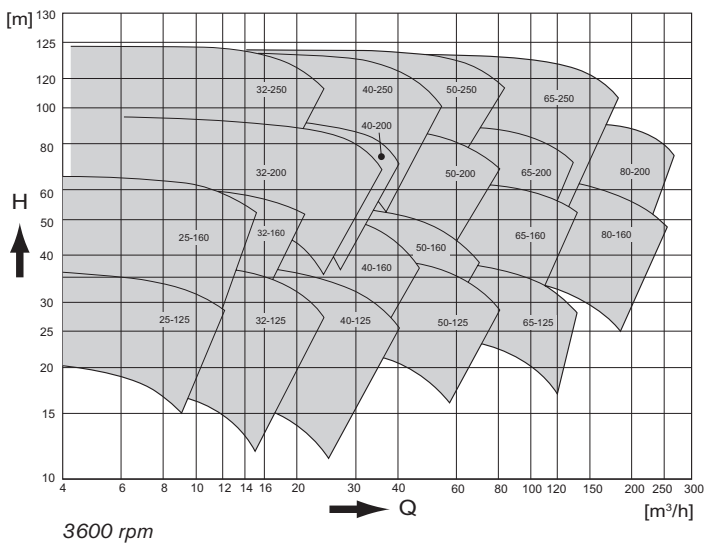
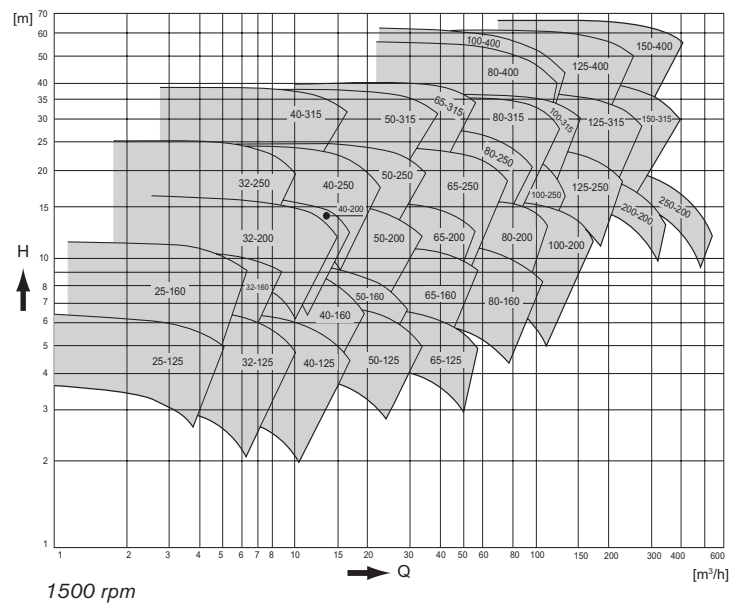
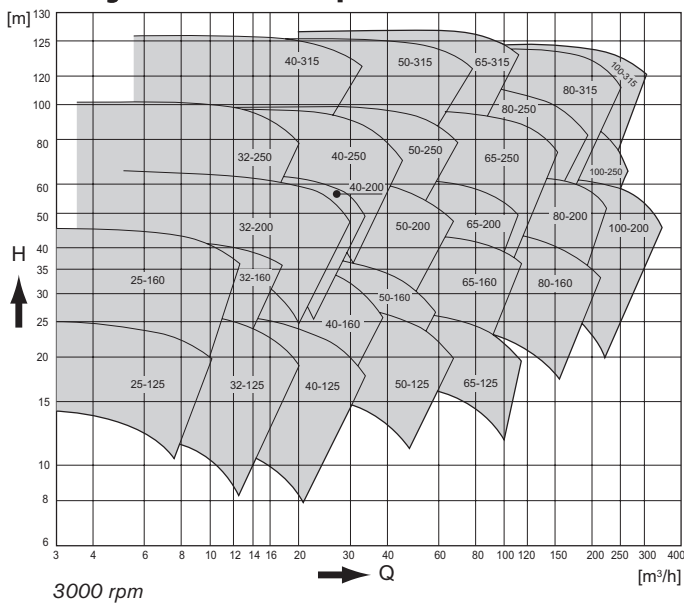

Bearing

CombiChem has two bearing arrangements:

1. two deep-groove ball bearings (grease lubricated "sealed for life")
2. a double-row angular contact ball bearing in combination with a roller bearing

Both versions can be provided grease lubricated as well as oil lubricated. Adjustable bearings for half-open impeller.

Grease lubrication

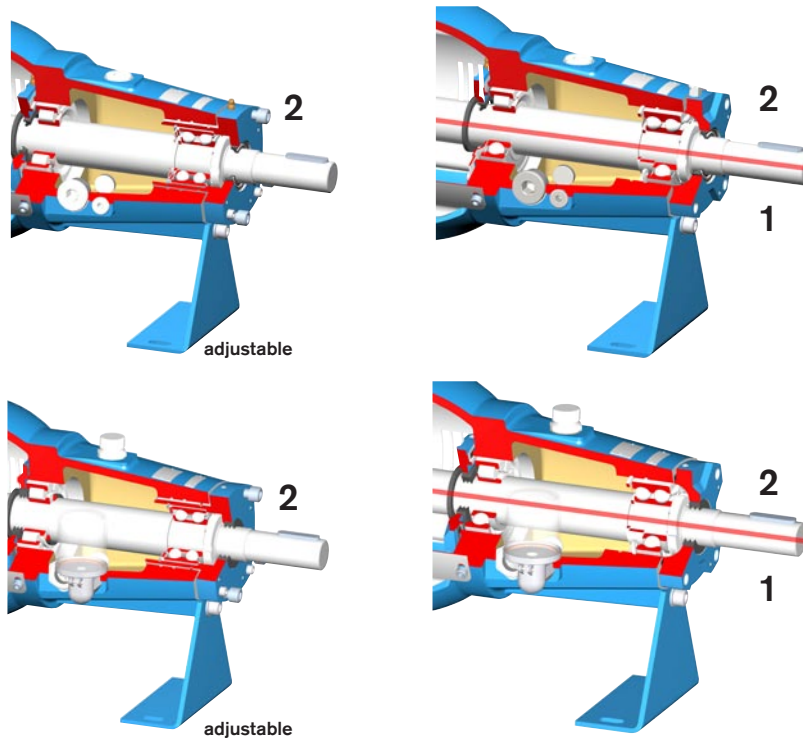

Oil lubrication

SPX[®]
WHERE IDEAS MEET INDUSTRY

Your local contact:



SPX Process Equipment NL B.V.
Dr A.F. Philipsweg 51, P.O. Box 9
NL-9400 AA Assen, NETHERLANDS
Phone: +31 (0)592 37 67 67. Fax: +31 (0)592 37 67 60
E-Mail: jp-industry.nl@processequipment.spx.com

For more information about our worldwide locations, approvals, certifications, and local representatives, please visit www.johnson-pump.com and www.spxpe.com.

SPX Corporation reserves the right to incorporate our latest design and material changes without notice or obligation. Design features, materials of construction and dimensional data, as described in this bulletin, are provided for your information only and should not be relied upon unless confirmed in writing.