



JOHNSON PUMP
AN SPX BRAND

CombiBloc

Close-coupled centrifugal pumps



CombiBloc

CombiBloc is the premier solution for pumping clean thin liquids in a very cost-effective way. The pump is part of Johnson Pump's Combi-system, a modular programme of single stage centrifugal pumps with a high degree of interchangeability of parts between the different pump constructions.



CombiBloc represents a range of horizontal centrifugal pumps close-coupled to electric motors. The pump is suitable for handling low-viscosity, clean or slightly contaminated and aggressive liquids.

Characteristic of the CombiBloc is the compact configuration of the pump and the electric motor assembly. The use of a stub shaft allows standard IEC electric motors to be used.

Thanks to the small number of components and the use of a mechanical seal, the CombiBloc requires little maintenance. This is further supported by Back Pull Out of the rotating assembly.

The CombiBloc has applications in crop farming and market gardening, on board ships and in handling various chemicals.

Technical data

Max. capacity	850 m ³ /h
Max. head	105 m
Max. working pressure	10 bar
Max. temperature	120 °C
Max. speed	3600 rpm



Test bed SPX Process Equipment NL in Assen

From know-how to finding solutions



General industry

The CombiBloc can be applied as a general duty pump in many industrial applications. Because of its economic features and ease of construction this pump is also ideally suited for space saving OEM skid mounting.



Shipbuilding

CombiBloc pumps can handle both clean and slightly contaminated fresh water and sea water. Their compact, space saving build makes them ideal pumps for engine rooms and general duty.



Utility

Applications of the CombiBloc within utility buildings are as general duty pumps, circulation pumps in heating and air-conditioning systems and pumps in water purification plants.



Horticulture

In horticulture the CombiBloc is used as a transport pump for hot water heating systems.

Features and *benefits*

Pump casing

- flanges according to ISO 7005
- max. working pressure 10 bar
- drain opening
- *wide range of applications*
- *complete and fast draining of the casing*

Pump cover

- flat gasket, fully chambered
- machined fits
- *no gasket blow-out*
- *perfectly aligned*

Suction capabilities

- smooth suction entry in pump casing
- smooth surface
- anti rotation vane
- *optimum suction capabilities*
- *minimal flow distortion giving better suction capabilities*

Impeller locking

- impeller nut with spring washer
- *reliable locking*

Hydraulic balancing

- flat cover for hydraulic balancing
- back vanes for hydraulic balancing
- *extended bearing life time*

Foot

- machined foot
- *exact positioning on base and in pipework*

Materials

- pump casing: cast iron - bronze - stainless steel
- impeller: cast iron - bronze - stainless steel
- stub shaft: stainless steel

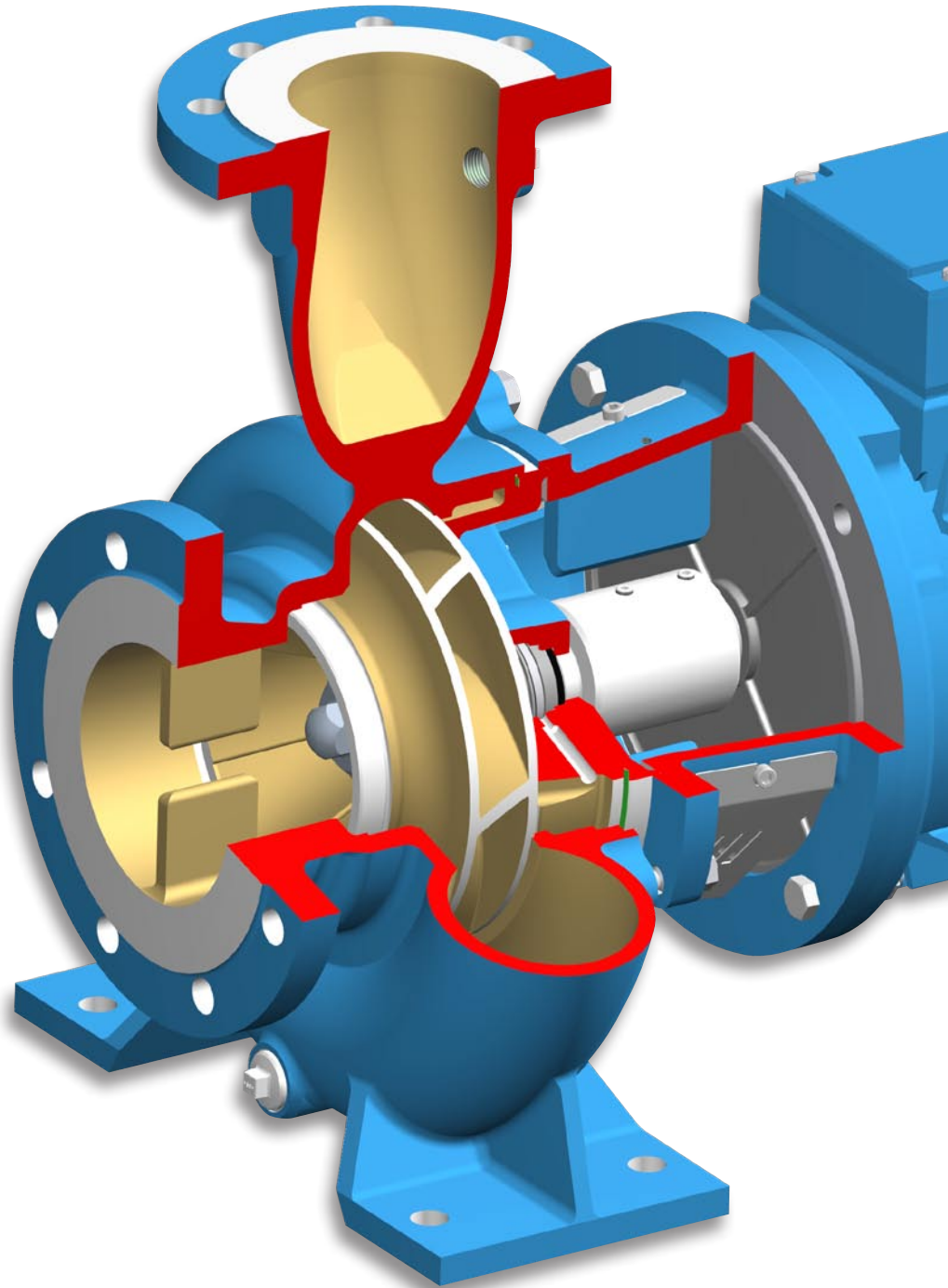

Coupling guard

- consisting of 2 identical parts with snap fit
- aluminium
- *quick and easy mounting*
- *for increased safety*
- *non sparking*

Electric motor

- standard IEC size flange motor
- fixed bearings
- larger pump sizes mounted with foot-flange motor
- *independence of motor make*
- *economic*
- *reliable*
- *readily available*

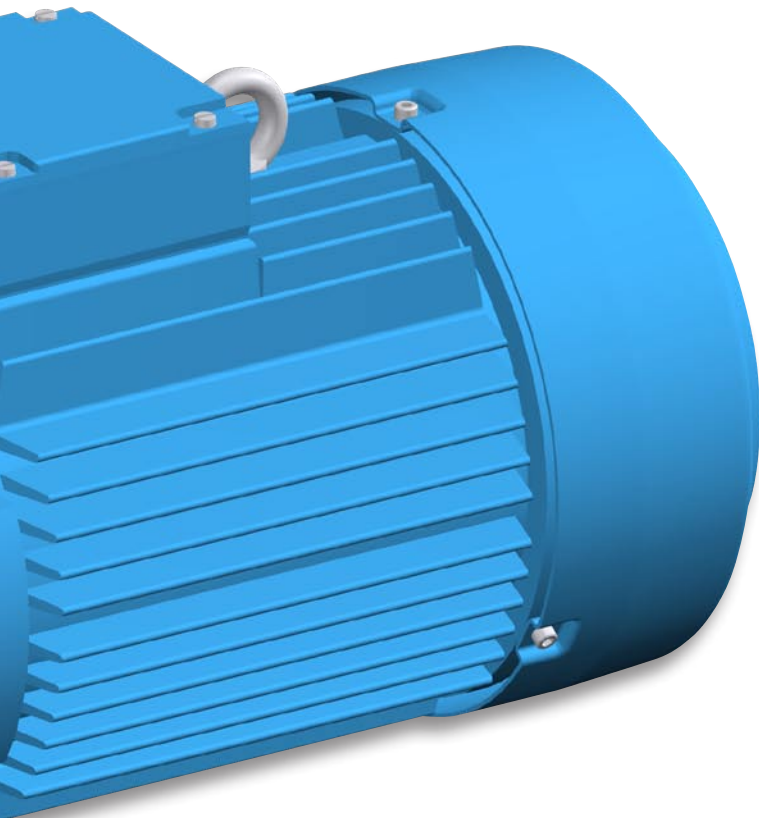

Seal chamber

- seal chamber integrated in pump cover
- large and tapered shape
- internal seal flushing bore to seal chamber
- *perfect alignment resulting in increased seal life*
- *better drainage of seal chamber*
- *ample seal flushing*
- *no external flushing piping needed*

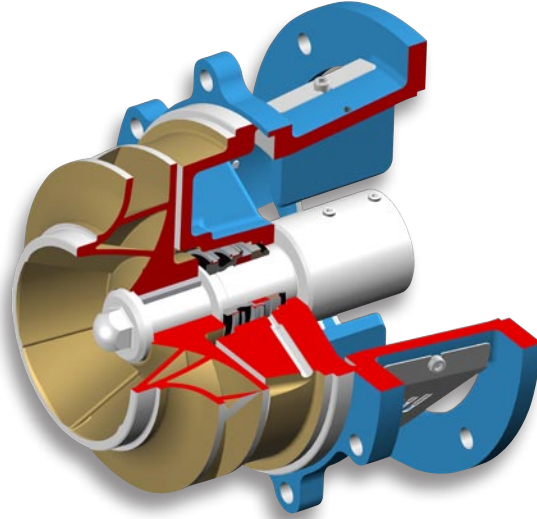

Shaft sealing

- mechanical bellows seal according to EN 12756 (DIN 24960 L_{1k})
- several material combinations
- *no O-ring lock up*
- *interchangeable with other EN (DIN) seal makes*
- *suitable for many liquids*

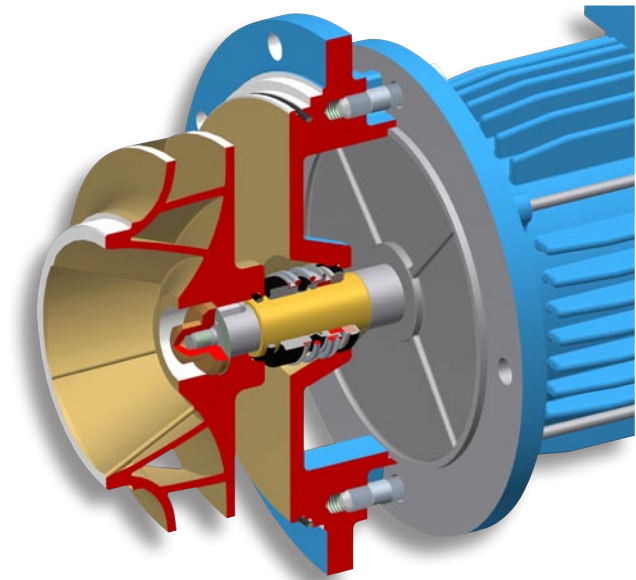

Easy and low cost maintenance

- pump cover and lantern piece mounted to pump casing as one unit, no separate bolting
- quick and easy impeller replacement
- only 3 mechanical seal sizes
- changeable wear ring (only bearing bracket 2 and 3)
- *easy to disassemble pump cover*
- *economic maintenance*
- *extended pump life time*

Lantern piece

- rigid cast iron construction
- machined fits
- large openings
- *exact alignment*
- *easy access for inspection and service*

Stub shaft

- stainless steel AISI 316
- fits to IEC electric motors
- axial fixation with set screws
- 3 shaft diameters
- *no shaft sleeve needed*
- *easy impeller replacement*
- *adjustable axial impeller position*
- *low maintenance cost*

Hydraulic performance data

These curves are based upon *nominal* electric motor speeds. The actual pump performance curves may vary from these curves, depending on the actual electric motor speed.

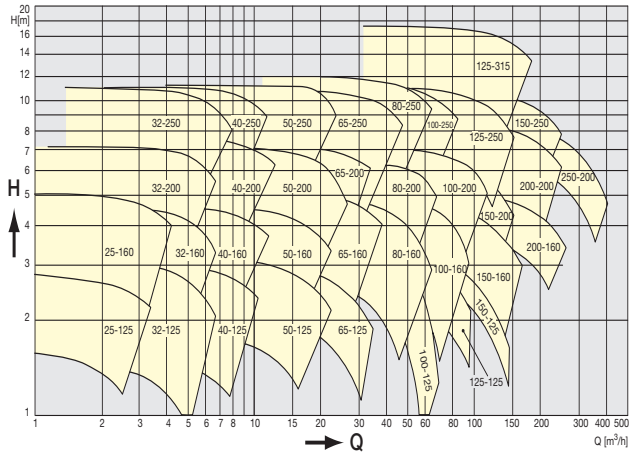

$n_{nom} = 1000 \text{ rpm}$ (6 pole electric motor - 50 Hz)

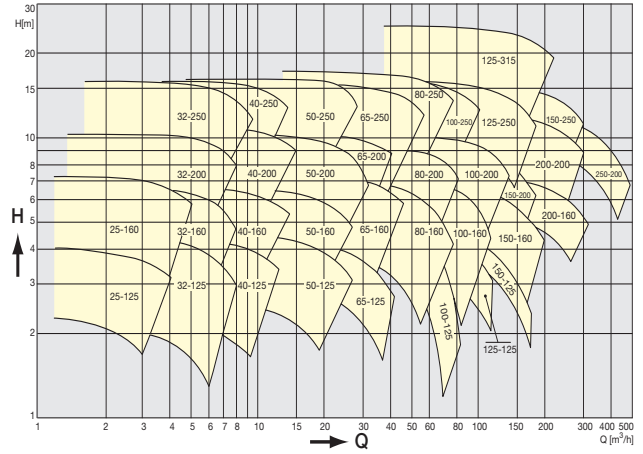

$n_{nom} = 1200 \text{ rpm}$ (6 pole electric motor - 60 Hz)

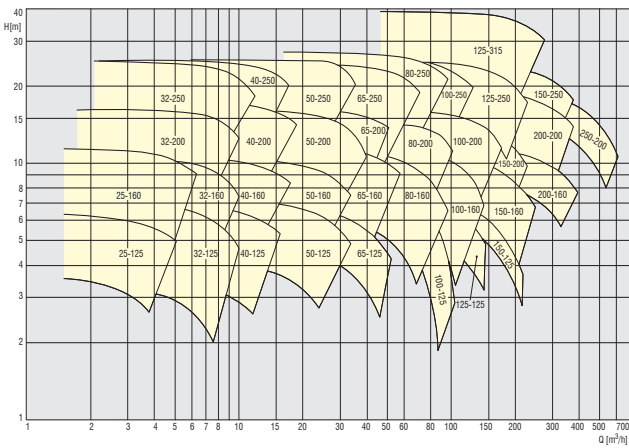

$n_{nom} = 1500 \text{ rpm}$ (4 pole electric motor - 50 Hz)

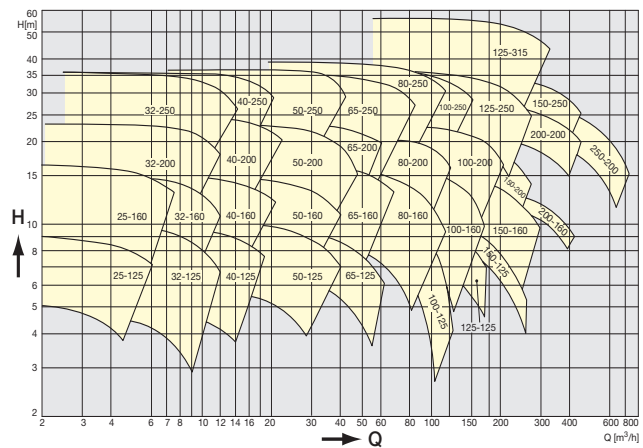

$n_{nom} = 1800 \text{ rpm}$ (4 pole electric motor - 60 Hz)

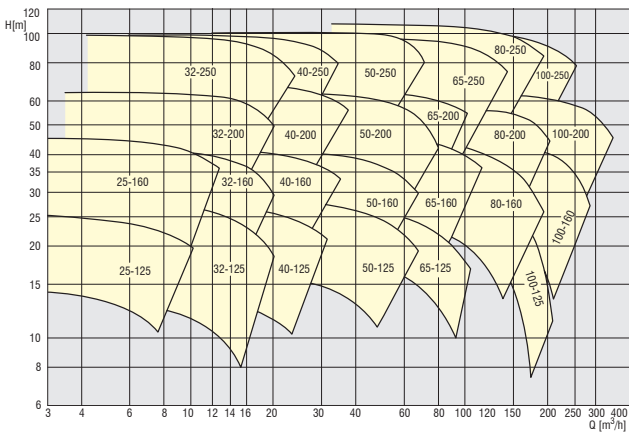

$n_{nom} = 3000 \text{ rpm}$ (2 pole electric motor - 50 Hz)

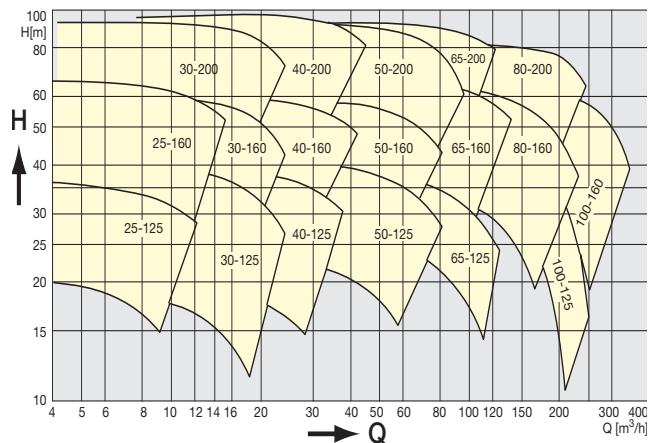

$n_{nom} = 3600 \text{ rpm}$ (2 pole electric motor - 60 Hz)

Dimensions

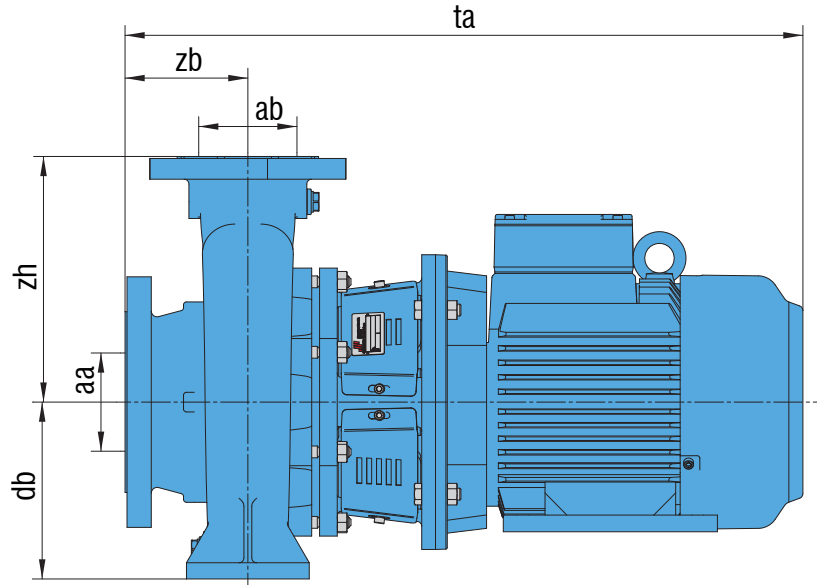

ta: based on DIN 42677, actual size depending on motor make
 ISO 7005 PN 16 \cong EN 1092-2 (EN 1092-1 stainless steel)
 * = ISO 7005 PN 6 \cong EN 1092-2 (EN 1092-1 stainless steel)
 ** = ISO 7005 PN 10 \cong EN 1092-2
 *** = stainless steel
 - = not available in stainless steel

CombiBloc	ISO 7005 PN 16				db	zb	zh	ta (max)
	aa	aa***	ab	ab***				
25-125	32*	32*	25*	25*	100	62	115	537
25-160	25	25	25	25	132	64.5/94.5***	142	607/637***
32-125	50	50	32	32	112	80	140	628
32-160	50	50	32	32	132	80	160	706
32-200	50	50	32	32	160	80	180	834
32-250	50	50	32	32	180	100	225	932
40-125	65	65	40	40	112	80	140	706
40-160	65	65	40	40	132	80	160	834
40-200	65	65	40	40	160	100	180	854
40-250	65	65	40	40	180	100	225	932
50-125	65	80	50	50	132	100	160	726
50-160	65	80	50	50	160	100	180	854
50-200	65	80	50	50	160	100	200	1060
50-250	65	80	50	50	180	100/125***	225	1080/1105***
65-125	80	100	65	65	160	100	180	854
65-160	80	100	65	65	160	100	200	1060/1070***
65-200	80	100	65	65	180	100	225	1060/1070***
65-250	80	100	65	65	200	100/125***	250	1142/1167***

CombiBloc	ISO 7005 PN 16				db	zb	zh	ta (max)
	aa	aa***	ab	ab***				
80-160	100	125	80	80	180	125	225	1085/1095***
80-200	100	125	80	80	180	125	250	1536
80-250	100	125	80	80	200/225***	125	280	1555
100-125	100	-	100	-	180/-	125	250	879
100-160	125	-	100	-	200/-	125	315	1100
100-200	125	125	100	100	200	125	280	1536
100-250	125	125	100	100	225	140	280	1585/1570***
125-125	125	-	125	-	225/-	140	300	894
125-250	150	150	125	125	250	140	355	1134
125-315	150	-	125	-	280/-	140	355	1136
150-125	150	-	150	-	280/-	160	400	786
150-160	150	-	150	-	250/-	160	315	1411
150-200	150	-	150	-	250/-	160	315	929
150-250	200	-	150	-	280/-	160	400	1050
200-160	200**	-	200**	-	280/-	200	400	969
200-200	200**	-	200**	-	280/-	200	400	1194
250-200	250	-	250	-	315/-	200	450	1202