

COPES-VULCAN



PRODUCT SPECIFICATION SHEET

SUBJECT: MA-IIIU Mechanical Atomizing Desuperheater

REVISION No.: 3

DATE April 4, 2002

PAGE No. 1 OF 8

1.0 INTRODUCTION

The MA-IIIU Mechanical Atomizing Desuperheaters reduce steam or gas temperatures by introducing cooling liquids directly into the hot fluid. The MA-IIIU is a probe style direct contact heat exchanger and is mounted by a universal flanged connection. The liquid passes through the main tube of the desuperheater to the spray nozzles and discharges into the header.

The MA-IIIU is generally used for applications which feature steady and transient loads. The primary use is for interstage attemperation of high pressure and temperature superheated steam and is specially designed for intermittent use. It is well suited for applications where limited differential pressure is available for injection purposes. The MA-IIIU is also designed for higher capacities than the MA-I and SAMN.

2.0 DESIGN AND INSTALLATION

The standard MA-IIIU unit is flange mounted. The Injection tube is machined from a single forged bar. A uniquely designed cap is welded to the tube and to a specially machined 3" raised face blind flange. This design is better suited for thermal expansion and accommodates flanged header mounting, (universal bolted connection).

There are no special supports or adapters required for installation. The fitting material used for the header connection should be ASME SA-182 GR. F22/ASTM A182 GR. F22, which will match application requirements for high temperatures, minimize variations of field welds, and result in section I compliant materials.

A series of injection nozzles are fitted to the end of the injection tube and it is inserted through the header connection. The minimum bore diameter for a 3" connection is 2.90" for installation clearance.

The standard water connection is a 2" socket or butt weld preparation. The butt weld connecting pipe schedule must match customer requirements to ensure proper end preparation.

A separate cooling valve is required. The controllability of the water is directly related to the nozzle performance. The nozzles operate between 30 and 500 psi differential pressure with full capacity of all nozzles being at 230 psi.

The MA-IIIU Desuperheater is designed in accordance with the following standards:

ASME B31.1 - 2001
ASME B16.5a - 1998

COPES-VULCAN

 **SPX VALVES & CONTROLS™**

PRODUCT SPECIFICATION SHEET

SUBJECT: MA-IIIU Mechanical Atomizing Desuperheater

REVISION No.: 3

DATE April 4, 2002

PAGE No. 2 OF 8

3.0 MATERIALS OF CONSTRUCTION

Injection tube (probe)	ASME SA-182 GR. F91/ASTM A182 GR. F91
Nozzle Head	ASME SA-182 GR. F91/ASTM A182 GR. F91
Plunger Stop	ASME SA-182 GR. F91/ASTM A182 GR. F91
Nozzle Plunger	422 SST ASTM A565 GR. 616 UNS S42200 COND HT PLASMA NITRIDED (ref CVI Procedure 1.3.190)
Spring Retainer	422 SST ASTM A565 GR. 616 UNS S42200 COND HT (ref CVI Procedure 1.3.188)
Disc Springs	INCONEL 718 (Heat treated and aged)
Groove Pin (ANSI Type A)	INCONEL 718 (Heat treated and aged)
Thermal Sleeve	ASME SA-335 GR. P91/ASTM A335 GR. P91
Mounting Flange	ASME SA-182 GR. F22/ASTM A182 GR. F22
Welding Cap	ASME SA-182 GR. F91/ASTM A182 GR. F91
Socket weld coupling	ASME SA-182 GR. F91/ASTM A182 GR. F91

4.0 LINE SIZES

The MA-IIIU can be furnished for installations in line sizes from 8" through 30".
The minimum inside diameter of pipe or thermal liner (if used) is as follows:

2 Nozzles -----	6.81"
3 Nozzles -----	8.50"
4 Nozzles -----	11.00"
5 Nozzles -----	14.00"

5.0 PRESSURE CLASSES

ANSI Pressure class 900, 1500, 2500

6.0 INLET CONNECTION

The end is machined for 2" NPS SCH 40, 80, or 160 butt weld. A socket weld connection is also offered.

7.0 TEMPERATURE LIMITATIONS

Maximum 1100° F inlet steam. For steam temperatures exceeding 950° F a Thermal Sleeve will be used in the nozzle tube and minimum water temperature will be limited to 270° F.

COPES-VULCAN



PRODUCT SPECIFICATION SHEET

SUBJECT: MA-IIIU Mechanical Atomizing Desuperheater

REVISION No.: 3

DATE April 4, 2002

PAGE No. 3 OF 8

8.0 VELOCITY LIMITATIONS

Maximum steam velocity = 30,000 ft/min

Minimum steam velocity = 1800 ft/min*

* Dependant upon the amount of residual superheat and temperature differential between vapor and water.

9.0 MINIMUM SUPERHEAT

This product can maintain temperatures to within 15° F above saturation.

10.0 TEMPERATURE CONTROL TOLERANCES

The controllable process temperature is within +10° F of setpoint

11.0 NOZZLE PRESSURE DROP

The Maximum water pressure over line pressure is 500 psi. The first nozzle (A) will begin to open at 30 psi and all nozzles will be fully open at 230 psi. A limit of 500 psi will prevent the failure of nozzle components at high temperatures.

12.0 RANGEABILITY

The rangeability is the ratio between the maximum and minimum controllable Cv through the unit, which will vary depending on the number of nozzles used in the unit. A two nozzle, the smallest unit, will be 13:1 and the largest will be a five nozzle unit, 33:1.

13.0 TEMPERATURE BULB LOCATION

The location of the temperature sensing point is dependant upon the thermodynamic conditions and will usually vary between 16 and 30 feet.

14.0 ORIENTATIONS

Any, (nozzles must face downstream)

15.0 THERMAL LINER

A thermal liner is usually recommended.

COPES-VULCAN



PRODUCT SPECIFICATION SHEET

SUBJECT: MA-IIIU Mechanical Atomizing Desuperheater

REVISION No.: 3

DATE April 4, 2002

PAGE No. 4 OF 8

16.0 CAPACITY AND TURNDOWN

Capacity is based on the number of nozzles required for the application C_v . Each nozzle has a capacity of 3.3 C_v . (Refer to Chart 1).

17.0 MINIMUM CONTROLLABLE C_v

The minimum controllable C_v is 0.5 with nozzle A.

18.0 THERMAL SLEEVE

A thermal sleeve will be welded into the tube for applications exceeding 950°F.

19.0 OUTLINE DIMENSIONS

(Refer to figures 1-2).

COPEs-VULCAN

SPX VALVES & CONTROLS™

PRODUCT SPECIFICATION SHEET

SUBJECT: MA-IIIU Mechanical Atomizing Desuperheater

REVISION No.: 3

DATE April 4, 2002

PAGE No. 6 OF 8

FIGURE 1

MA-IIIU

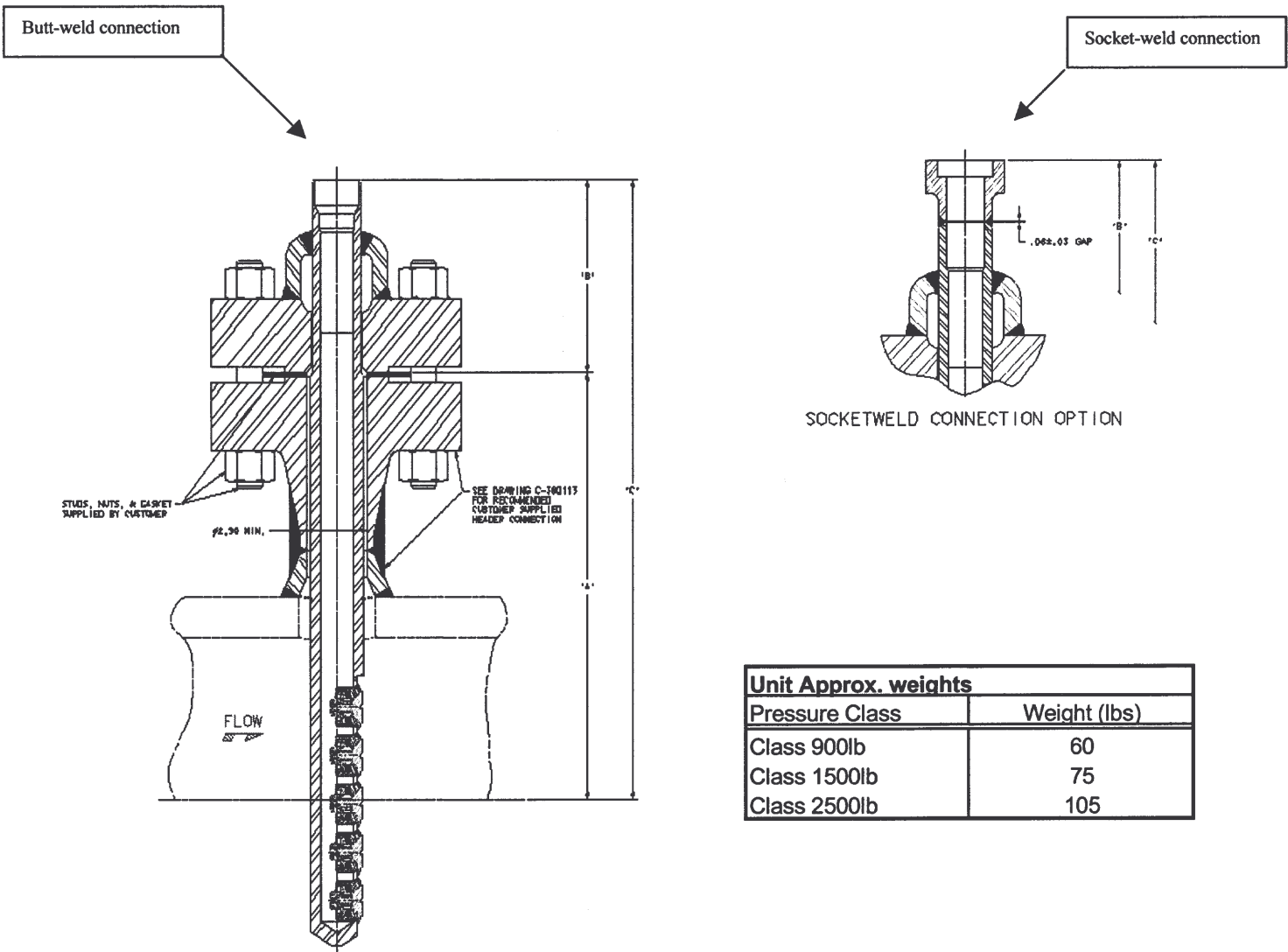

COPES-VULCAN



PRODUCT SPECIFICATION SHEET

SUBJECT: MA-IIIU Mechanical Atomizing Desuperheater

REVISION No.: 3

DATE April 4, 2002

PAGE No. 7 OF 8

FIGURE 2A

MA-IIIU

DIMENSIONS (BUTTWELD CONNECTIONS)							
HEADER SIZE	'A'	PRESSURE CLASS					
		900		1500		2500	
		'B'	'C'	'B'	'C'	'B'	'C'
16"	16.75	7.56	24.31	7.56	24.31	7.56	24.31
18"	17.75		25.31		25.31		25.31
20"	18.75		26.31		26.31		26.31
22"	19.75		27.31		27.31		27.31
24"	20.75		28.31		28.31		28.31
30"	23.75		31.31		31.31		31.31

DIMENSIONS (SOCKETWELD CONNECTION)							
HEADER SIZE	'A'	PRESSURE CLASS					
		900		1500		2500	
		'B'	'C'	'B'	'C'	'B'	'C'
16"	16.75	9.06	25.81	9.06	25.81	9.06	25.81
18"	17.75		26.81		26.81		26.81
20"	18.75		27.81		27.81		27.81
22"	19.75		28.81		28.81		28.81
24"	20.75		29.81		29.81		29.81
30"	23.75		32.81		32.81		32.81

