



# ProCam Sanitary Diaphragm Metering Pumps

Diaphragm pumps for sterile products. ProCam metering pumps are now available with CIP and SIP capability. The new ProCam Sanitary range uses food-grade components with ultra smooth surfaces and modified flow geometry which permits complete in-place cleaning of the membrane pump heads and the valves.

- **Capacity for each pumphead: 0.15 - 158 GPH**
- **Maximum operating pressure: up to 300 psi**
- Metering pumps with PTFE double diaphragm (FDA approved) and diaphragm monitoring service by pressure gauge or pressure switch.
- Front cover, valves and connections in material SS316L with surface roughness Ra 0.4 up to 0.8.
- Double diaphragm and gaskets made of PTFE (FDA approved).
- Clamp-connections 1/2" and 1".

## Applications

- Suitable for CIP (Cleaning-in-Place) up to 300° F.
- Suitable for SIP (Sterilizing-in-Place) by saturated steam at 250° F.
- Particularly suitable for hygienic applications in the pharmaceutical industry and biotechnology, in cosmetic industries and personal care as well as for food and beverages.

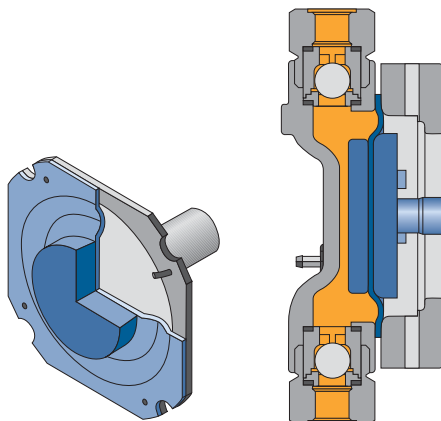

Hygienic design of diaphragm pumphead with PTFE double diaphragm (FDA).





Electropolished pumphead and connections with surface roughness Ra <0.4 for easy cleaning.



Optimized ball valve with surface roughness Ra 0.4.

PROCAM CAPACITY CHART						
Type	Nominal Max. Capacities (GPH) @ Stroke Speeds				Max. Pressure* Psig.	Connections NPT
Gear Ratio Stroke Speed	28:1 60	19:1* 86	28:1 120	19:1* 172		
*39:2 for DS or DP 200 + 500						
<b>316 Stainless Steel Pumphead</b>						
DS 15	1.6	2.4	3.2	4.7	300	3/8"
DS 50	5.5	7.9	11.1	15.8	150	3/8"
DS 100	11.1	15.8	22.2	31.6	60	1/2"
DS 200	22.2	31.7	44.4	63.4	150	1/2"
DS 500	55.5	79.3	111	158.5	60	1"



PROCESS EQUIPMENT

Your local contact:



SPX Process Equipment, Bran+Luebbe Operation  
 611 Sugar Creek Road, Delavan, WI 53115  
 Phone: (800) 252-5200 or (262) 728-1900, Fax: (262) 728-4904  
 E-mail: bl@spx.com

**Packaging - Processing**  
**Bid on Equipment**  
 1-847-683-7720  
[www.bid-on-equipment.com](http://www.bid-on-equipment.com)

For more information about our worldwide locations, approvals, certifications, and local representatives, please visit [www.spxpe.com](http://www.spxpe.com).

SPX Corporation reserves the right to incorporate our latest design and material changes without notice or obligation. Design features, materials of construction and dimensional data, as described in this bulletin, are provided for your information only and should not be relied upon unless confirmed in writing.