

Motor-driven mixers for the most exacting liquid mixing requirements

PENTAX mixers are used where two mutually insoluble liquids must be continuously mixed into a stable emulsion, or where solids in suspension must be dispersed as finely as possible in a viscous liquid.

PENTAX

Multi-Frequency Fluid Mixers

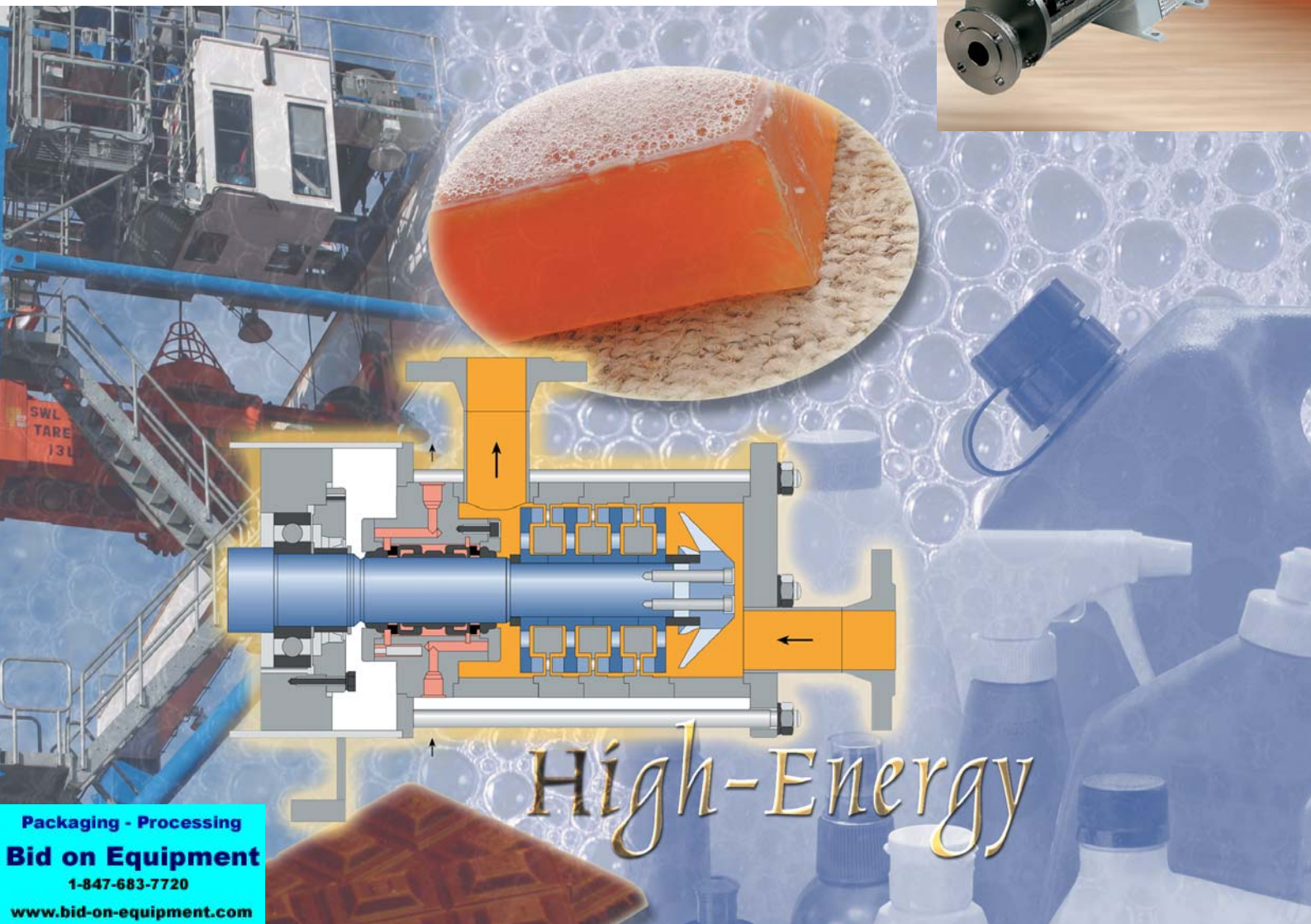



Applications

■ Chemicals and plastics

Dispersing hardeners, accelerators and colorants into resins.
Continuous cross-linking of PVA solutions.
Production of anionic and cationic bitumen emulsions.
Continuous molten resin saponification.
Wax and paraffin emulsion preparation.
Dispersing propellant in foams.

■ Food

Continuous production of mayonnaise.
Fine dispersion of additives in cocoa and chocolate.
Soya milk drink production.
Dispersion of citric acid in vegetable oil.
Homogenization of nut-nougat sandwich spread.
Preparation of beaten egg-white/sugar foam mixtures.

■ Cosmetics and detergents

Continuous manufacture of creams and emulsions.
Alkaline neutralization of fatty and sulphonic acids.

Dilution of molten alkane sulphonate.
Elimination of viscosity anomalies in alkyl ether sulphate dilutions.
Continuous shampoo and dish-washing liquid production.

■ Fibres and textiles

Dyeing and delustering for semi- and fully synthetic spinning solutions.
Homogenization for viscose solutions.
Production of lubricant emulsions.
Continuous starch gelatinization.

Design and construction

The multi-frequency liquid mixer comprises a series of opposed rotors and stators on a common axis. The rotors are fitted with milled teeth for low viscosity applications and with round studs for use with viscous fluids.

Inside the PENTAX mixer, constantly changing areas of rapid flow and resistance subject the

liquid to high frequency acceleration and deceleration. The resulting high energy shear forces result in effective dispersion and emulsification.

A pre-mixing chamber is located at the entrance to the mixer. When one or more components are fed in by non-synchronous piston or diaphragm pumps, this

chamber accommodates the discharge volume of several pump strokes and thereby equalizes any differences in concentration before the liquids enter the main mixing area.

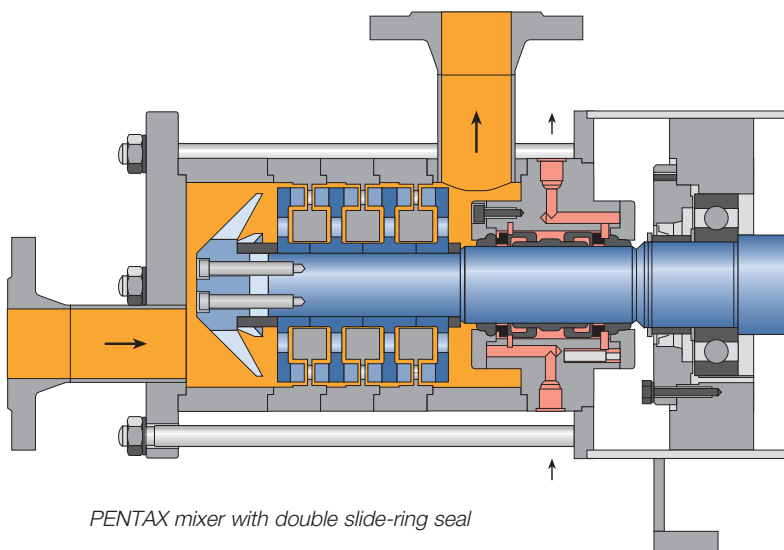

PENTAX mixer with double slide-ring seal

Advantages

- Extremely fine droplet size and material distribution
- Low space requirement
- High shearing action and phase boundary area
- Rapid reaction rate for neutralization and other reactions
- Effective material exchange for reactions involving gases

Specifications

Type	Connection DN	Through-put ^{1.)} l/h	Speed range min ⁻¹	Drive power kW	Rotor diameter d _a mm	Power coefficient	
						Re > 10 ⁴ NE	Re < 200 Ne . Re
KMF 8	25	40 – 800	500/4500	2 – 4.0	72	4.2	6000
KMF 15	40	150 – 3000	500/4000	2 – 9.5	94	3.0	3000
KMF 30	50	400 – 6000	350/2800	4 – 18.5	149	2.2	2100
KMF 70	80	900 – 12000	250/1450	5 – 22	236	1.5	1800
KMF 120	100	1500 – 18000	200/ 950	15 – 30	254	1.0	1500
KMF 250	100	2500 – 30000	150/ 750	15 – 30	317	0.7	1200
KMF 300	150	4000 – 50000	100/ 450	22 – 45	515	0.5	1000

^{1.)} For special applications higher throughputs may be acceptable.

The table above indicates the relationship between throughput, drive power and rotation speed. Low viscosity applications require high throughput and rotation speed with a low power rating; high viscosity applications require the opposite.

As many products exhibit non-Newtonian flow characteristics, it is not normally possible to determine the effective viscosity within the mixer; in these cases test runs in our pilot plant are required.

PENTAX mixers can be supplied with fixed gearing via a directly coupled motor, or with variable-speed drives.

Connections and dimensions

Type	Connection DN	Dimensions (mm)									approx. dimensions	
		A	B	C	D	E x E'	F x F'	G	H	K	L	
KMF 8	25	230	92	128	298	190x180	165x155	13	110	600	1015	
KMF 15	40	303	116	166	383	200x240	170x210	14	142	630	1235	
KMF 30	50	334	170	255	477	260x265	210x215	19	215	900	1600	
KMF 70	80	389	172	303	488	470x380	420x330	19	245	–	1700	
KMF 120	100	445	165	310	657	500x400	440x350	24	260	–	2100	
KMF 250	100	470	210	385	593	410x450	350x400	24	315	–	2400	
KMF 300	150	400	333	437	707	750x610	684x560	24	333	–	2500	

