



**Model UT450-04  
Digital Indicating Speed Controller  
Operating Manual**

**Read and understand this manual  
prior to installing, operating or servicing this equipment**

# Table of Contents

Section 1.0 Controller Information .....	5
Section 2.0 Installation .....	5
2.1 Location .....	5
2.2 Mounting Procedure .....	5
2.3 Terminal Wiring .....	7
2.4 Speed Control Wiring .....	8
Section 3.0 Front Panel.....	9
Section 4.0 Key Operations .....	10
4.1 Operation Display.....	10
4.2 Setting Setpoint (SP).....	11
4.3 Switching between AUTO and MAN.....	11
4.4 Switching between RUN and STOP .....	12
4.6 Manipulating Control Output during Manual Operation .....	14
Section 5.0 Controller Parameters .....	14
5.1 Getting to Controller Parameters .....	14
5.2 Operating Parameter Flow Chart.....	15
5.3 Setup Parameter Flow Chart.....	16
5.3.1Speed Controller Operating Parameters .....	17
5.3.2Speed Controller Setup Parameters .....	17
Section 6.0 Maintenance.....	19
6.1 Troubleshooting Flow .....	19
6.2 Errors at Power On.....	20
6.3 Possible Errors During Operation.....	21
6.4 Remedies if Power Failure Occurs During Operations .....	22
6.5 Troubleshooting when the Controller Fails to Operate Properly .....	23
6.5.1The Controller Does Not Show the Correct Process Variable (PV).....	23
6.5.2The Controller Does Not Provide Any Control Output or the Control Output Does Not Change at All .....	23
6.5.3The Control Output Does Not Change Soon After the Target Setpoint (SP) Has Been Changed .....	23
Section 7.0 Parts Reference .....	24
7.1 Replacement Parts .....	24
7.2 Bran+Luebbe Parts .....	24
Section 8.0 Wiring terminal changes for converting UT35 to UT450 Installation .....	24
Section 9.0 Quick Set Up for Speed Controller.....	25
9.1 Process for setting the parameters on the Yokogawa UT450 Speed Controller.....	25
9.2 Speed Controller Operating Parameters .....	26
9.3 Speed Controller Set Up Parameters .....	27
9.4 Controller Wiring.....	29

## Table of Figures

Figure 1 - Mounting Positional Information .....	5
Figure 2 - External dimensions and panel cut out information.....	6
Figure 3 - Mounting bracket installation .....	6
Figure 4 - Speed Control application wiring .....	8
Figure 5 - Front panel of controller and function description .....	9
Figure 6 - Operations displays .....	10
Figure 7 - Setting Set Point on controller .....	11
Figure 8 - Auto/Manual Switching .....	11
Figure 9 - Run/Stop Setting.....	12
Figure 10 - Remote/Local Setting .....	13
Figure 11 - Manual Output Control .....	14
Figure 12 - Setting Controller Parameters .....	14
Figure 13 - Operating Parameter Flow .....	15
Figure 14 - Set Up Parameter Flow .....	16
Figure 15 - Trouble Shooting Guide.....	19
Figure 16 - Power Up Errors .....	20
Figure 17 - Operational Errors .....	21
Figure 18 - Power Failure Error Remedies .....	22
Figure 19 - Quick Set Up Controller Face .....	25
Figure 20 - Speed Control application wiring.....	29

## Section 1.0 Controller Information

The Yokogawa Model UT450-04 (Bran+Luebbe stock number **008881B**) is a standard digital controller from Yokogawa used for analog control. The unit will take 4-20 mA or DC voltage for Process Variable and Remote Setpoint inputs. External control for Remote/Local, Stop/Run and Auto/Manual is available.

This manual is intended to provide the information to properly set up and operate this controller when installed to meet speed control requirements with Variable Frequency Drives (VSD) for Bran+Luebbe metering pump applications. Any other use of this controller is not covered in this document. For general information on this controller, see the Yokogawa instruction manuals, either hard copy or CD (YOKOGAWA Green Series User's Manual Reference) that is provided with the controller.

Some of the information contained in this document is directly drawn from Yokogawa documents.

The controller parameters identified in Section 5 may need to be set to different values depending on the application and configuration used for the unit.

## Section 2.0 Installation

### 2.1 Location

Locate the controller where:

- 1) no one may accidentally touch the terminals
- 2) mechanical vibrations are minimal
- 3) corrosive gas is minimal
- 4) temperature can be maintained at about 23° C (73° F)
- 5) no direct radiant heat is present
- 6) no magnetic disturbances are caused
- 7) no exposure to water or other liquid (NEMA 4 Cover optional)
- 8) no flammable materials are present

Never place the controller directly on flammable items or equipment.

If installing the controller close to flammable items or equipment, provide shielding panels all around the controller, at least 150 mm (6 inches) away from each side. The panels should be made of either 1.43mm (16 gauge) thick metal plated steel panels or 1.6mm (14 gauge) thick uncoated steel plates.

### 2.2 Mounting Procedure

Install the controller on a vertical face, or such that the top of the controller will be no more than 30° below the horizontal with the front panel facing upward. Do not install it facing downward. The position of right and left sides should be horizontal

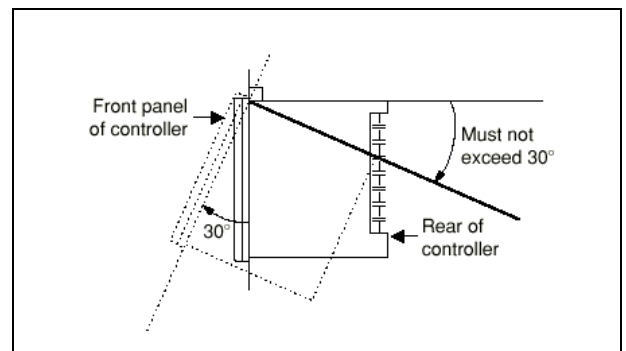

Figure 1 - Mounting Positional Information

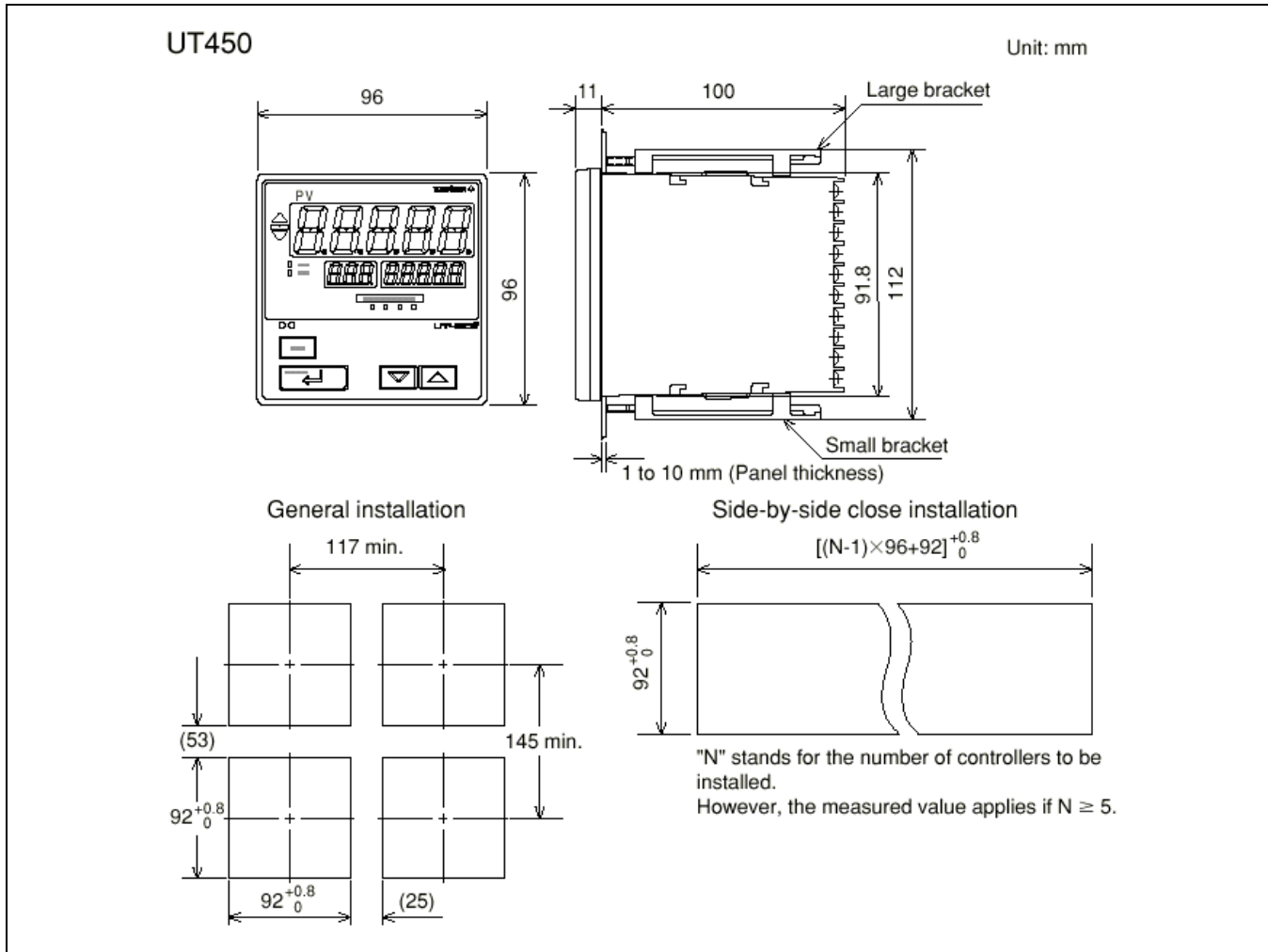

Figure 2 - External dimensions and panel cut out information

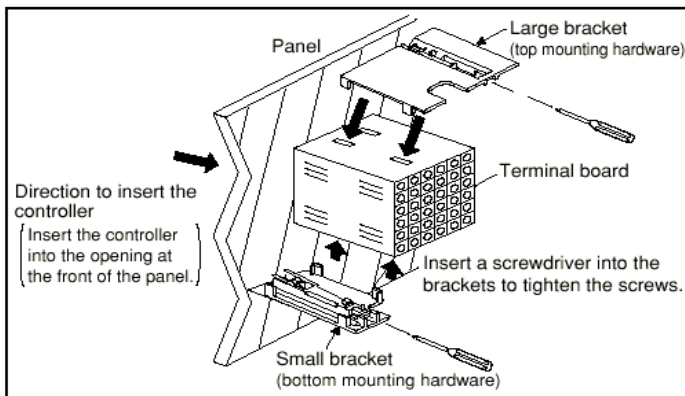

Figure 3 - Mounting bracket installation

1. Insert the controller into a panel cut out from the front of the panel.
2. Set the brackets in place on the top and bottom of the controller, and then tighten the screws of the brackets.  
Do not over-tighten.

### 2.3 Terminal Wiring

A fuse and power switch is not provided. Mount separately from the controller, if needed. Suggest a 250V time-lag fuse rated at 1A.

The alarm contacts on the unit are rated for 240V AC, 1A (Resistive load) or for 30 V DC, 1A (Resistive load). If this load is to be exceeded, install an interposing relay to handle the alarm load.

Provide power to the controller from a single-phase instrument power source of proper voltage. If there is noise on the power line, consider isolation transformer or a line filter for power protection. (Recommended line filters would be Control Concepts Islatrol Elite). A class 3 grounding must be provided (grounding resistance of 100 ohms or less).

Input and output signal wires should be kept away from power circuits, and VFD circuits. Use shielded wire for the actuator feedback lines and for remote set point lines.

Use crimping terminal lugs with insulating sleeves compatible with the wire gauge and terminal size for all connections to the controller and actuator.

2.4 Speed Control Wiring

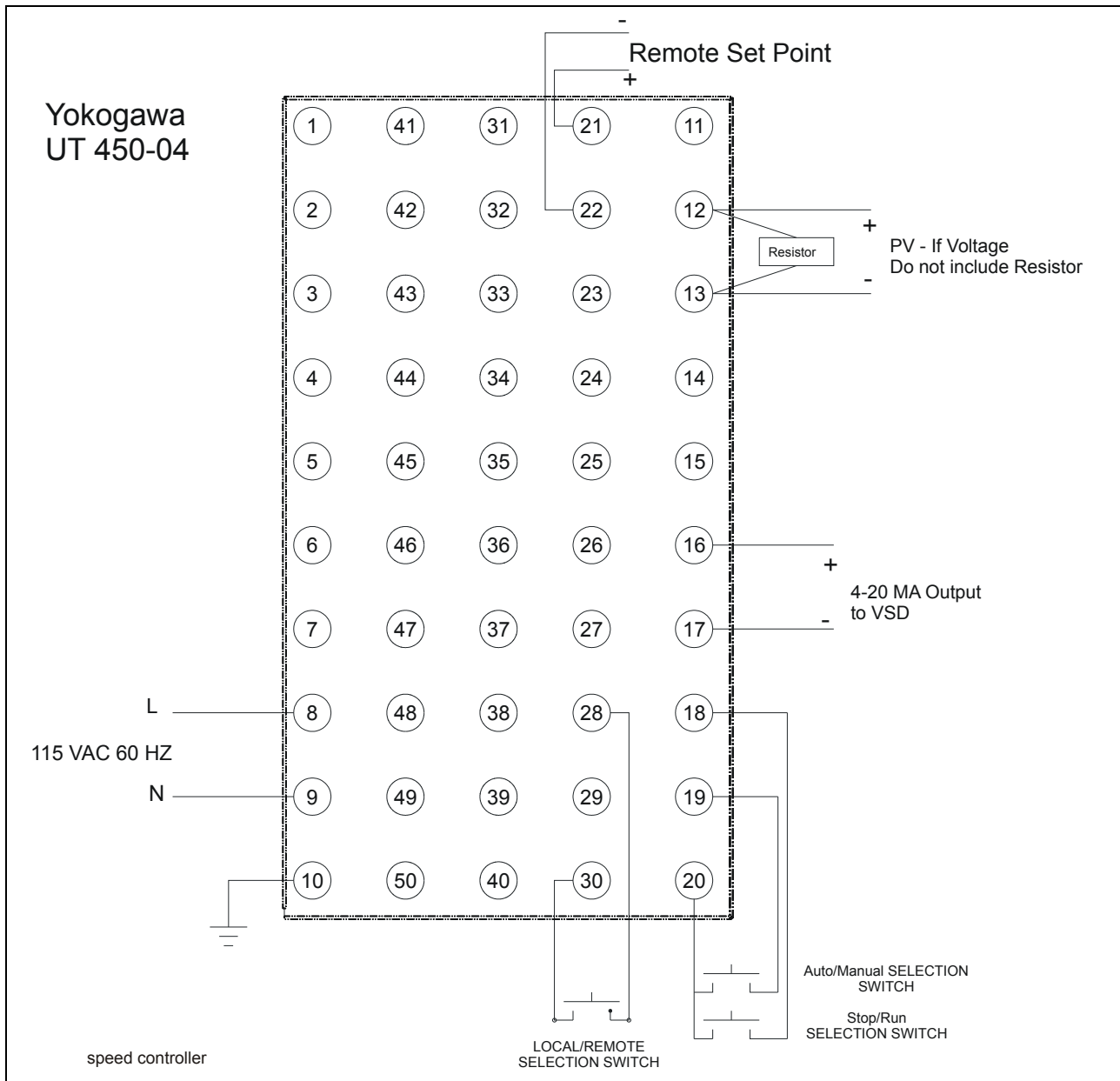
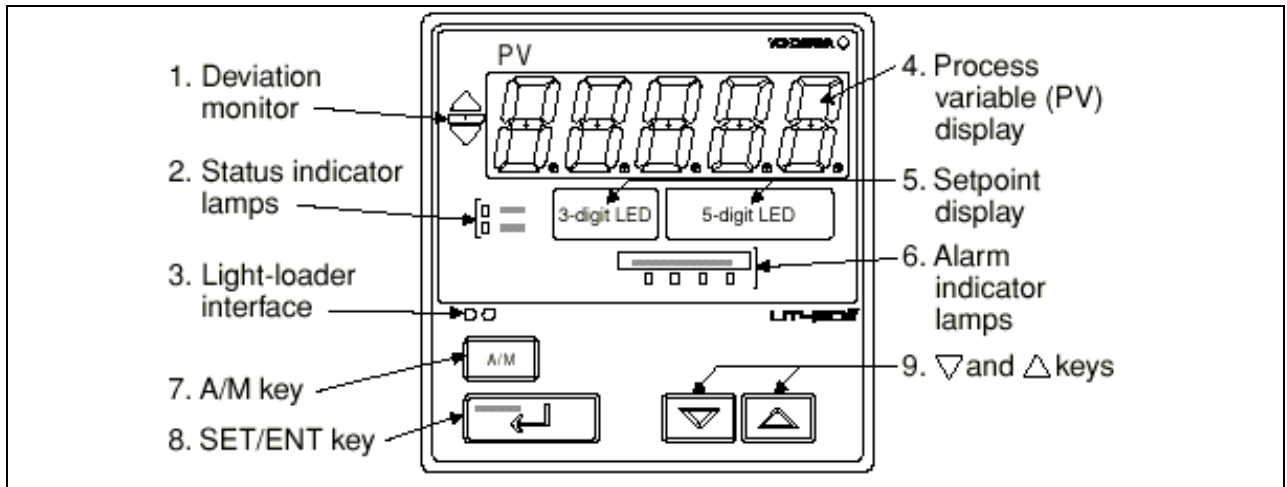

**Figure 4 - Speed Control application wiring**

If Local/Remote, Auto/Manual or Stop/Run features are not needed, it is not necessary to wire a switch for that function.

The unit is set up for a 1-5 VDC process variable and remote setpoint (if used)

Section 3.0 Front Panel



Name of Part	Function
1. Deviation monitor (for UT450 only)	When lit, indicates the status of a deviation (PV - SP). △ : Is lit (in orange) if a deviation exceeds the deviation display range. □ : Is lit (in green) when a deviation is within the deviation display range. ▽ : Is lit (in orange) if a deviation falls below the deviation display range. The deviation monitor goes off if any display other than the operating display or SELECT display is shown.
2. Status indicator lamps	Is lit (in green) to indicate the status of operation or control. REM: Is lit when in remote mode. MAN: Is lit when in manual mode. The lamp blinks when the controller is being auto-tuned.
3. Light-loader interface	Interface jack for an adapter cable used when setting and storing parameters from a PC. This requires an optional parameter setting tool.
4. Process variable (PV) display	Displays PV. Displays a menu symbol when you set a parameter. Displays an error code (in red) if an error occurs.
5. Setpoint display	Displays a parameter symbol in 3-digit LED. Displays the setpoint of a parameter in 5-digit LED.
6. Alarm indicator lamps	UT450: If any of alarms 1 to 4 occurs, the respective alarm indicator lamp (AL1 to AL4) is lit (in orange). UT420: If any of alarms 1 to 3 occurs, the respective alarm indicator lamp (AL1 to AL3) is lit (in orange).
7. A/M key	Used to switch between the AUTO and MAN modes. Each time you press the key, it switches to the AUTO or MAN mode alternately.
8. SET/ENT key	Used to switch or register a parameter. Pressing the key for more than 3 seconds allows you to switch between the operating display and the main menu for operating parameter setting display alternately.
9. ▽ and △ keys	Used to change numerical values. On setting displays for various parameters, you can change target setpoints, parameters, and output values (in manual operation). Pressing the ▽ key decreases a numerical value, while pressing the △ key causes it to increase. You can hold down a key to gradually increase the speed of change. To change from the parameter setting (operating or setup) display to the menu or from the setup parameter setting display menu to operating parameter setting display menu, press the ▽ and △ keys simultaneously.

Figure 5 - Front panel of controller and function description

## Section 4.0 Key Operations

### 4.1 Operation Display

Operating Display for the speed Controller

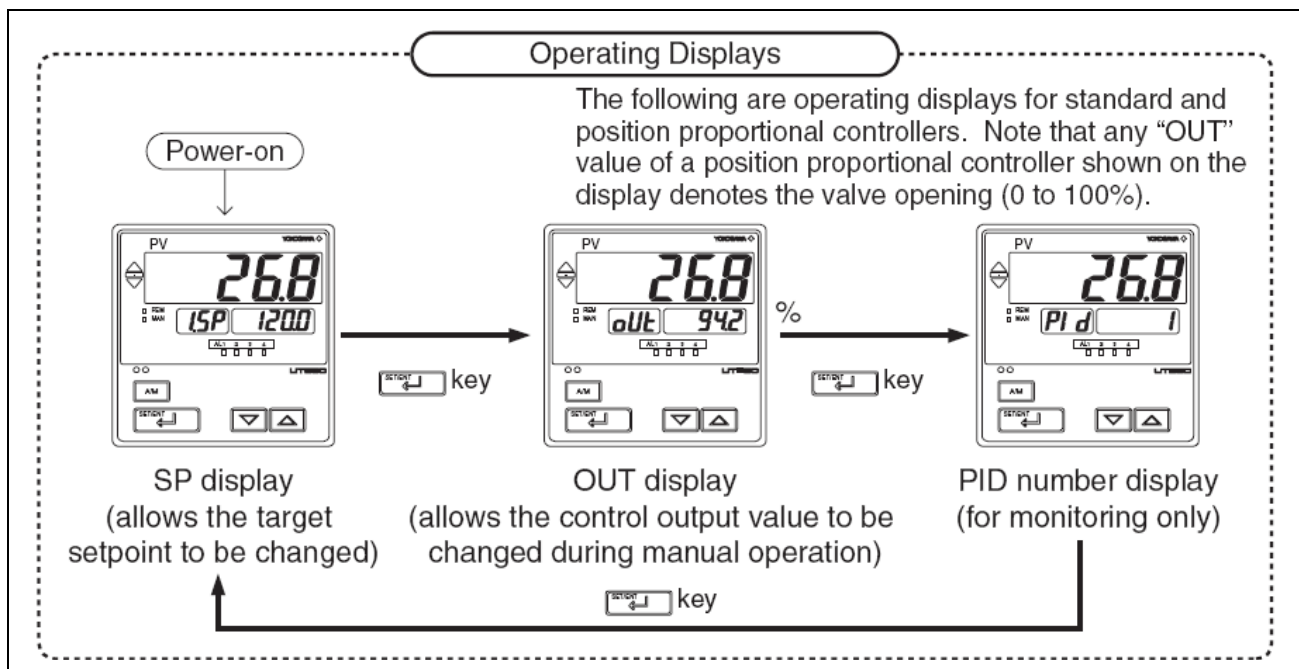

- SP Display
  - The PV input value appears on the PV display.
  - The target setpoint value (1.SP) appears on the Setpoint display.
- OUT Display
  - The PV input value appears on the PV display.
  - The control output value (OUT) appears on the Setpoint display.
  - When in position proportional control, the Setpoint display shows the valve opening (0% to 100%).
- PID Number Display
  - The PV input value appears on the PV display.
  - The PID number (PID) being used appears on the Setpoint display.



**Figure 6 - Operations displays**

4.2 Setting Setpoint (SP)

The following operating procedure describes an example of setting 150.0 to a target setpoint. In automatic operation, the controller starts control using set target setpoints.

1. Bring the operating display into view (display appears at power on).
2. Press the  or  key to display the required setpoint.
3. Press the  key once to register the value.

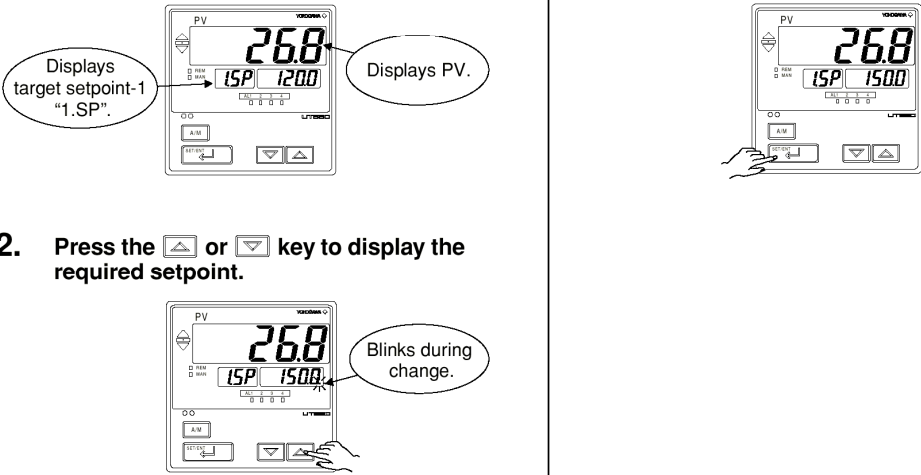



Figure 7 - Setting Set Point on controller

4.3 Switching between AUTO and MAN

 **NOTE**

If AUTO and MAN have been switched using contact input, when the contact input is ON, switching between AUTO and MAN cannot be achieved by keystroke.

1. Bring the operating display into view (display appears at power on).
2. Each time you press the  key on the front panel of the instrument, AUTO and MAN is switched alternately.

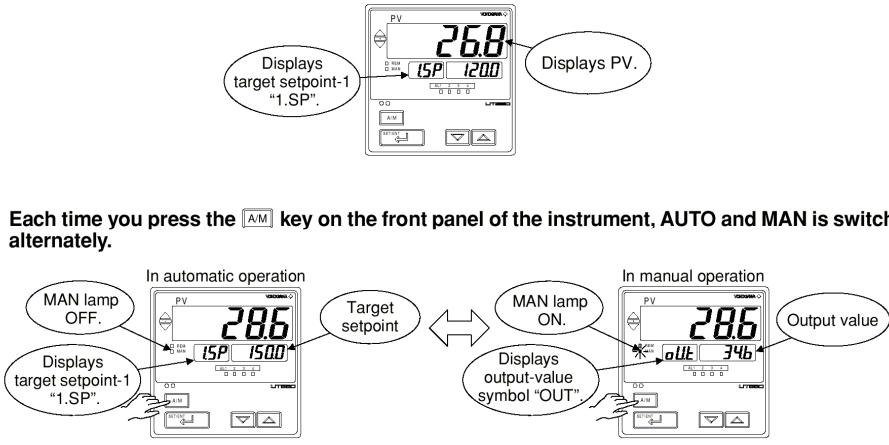

Figure 8 - Auto/Manual Switching

4.4 Switching between RUN and STOP

The following operation describes the procedure of switching from the run status to stop status.

 **NOTE**

Factory-shipped setting does not allow switching between run and stop by keystroke. To perform switching by keystroke, configure setup parameter “DIS = 0.”

When the controller is stopped, input and outputs are as follows:

PV input	Displays PV.
Control output	Preset output value (factory-shipped setting: 0%)
Alarm output	ON in the event of an alarm

1. Bring the operating display into view (display appears at power on).

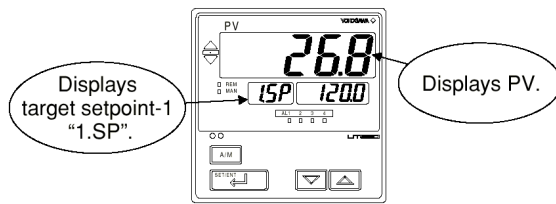

2. Press the  key for more than 3 seconds to call the menu “OP.PA”.

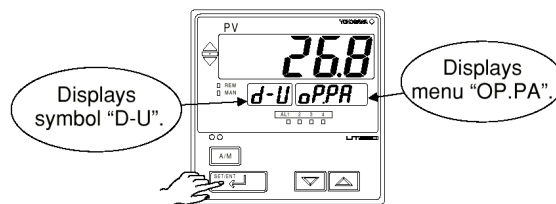

3. Press the  key several times to display the parameter “S/R”.

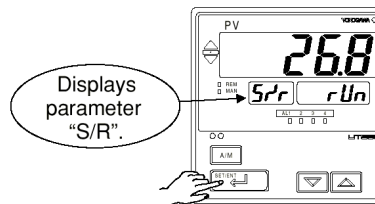

4. Press the  key to display “STOP”.

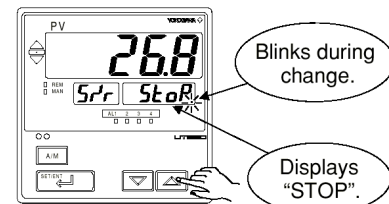

Figure 9 - Run/Stop Setting

4.5 Switching Between Remote (REM) and Local (LCL)

The following operating procedure describes an example of switching from Local (LCL) to remote (REM).

Switching between REM and LCL is possible for only controllers with remote input feature.

● **Local**

Performs control using target setpoints set in the controller.

● **Remote**

Performs control using external analog signals as target setpoints.

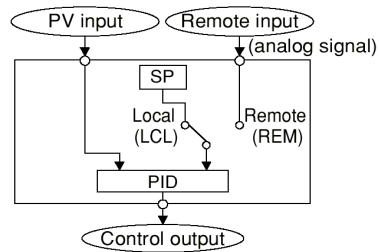

Note: The PID group number when the controller is in remote-mode operation is the same as the number set in the Target Setpoint Number (SPN) parameter.



**NOTE**

If remote status is achieved by external contact input (contact input is ON), switching between REM and LCL cannot be achieved by keystroke.

1. Bring the operating display into view (display appears at power on).

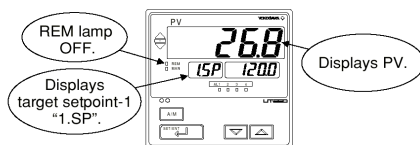

2. Press the **SETPOINT** key for more than 3 seconds to call up the menu "OP.PA".

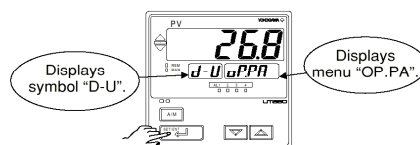

3. Press the **SETPOINT** key several times to display the parameter "R/L".

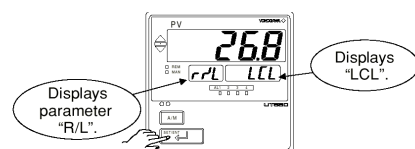

4. Press the **▲** key to display "REM".

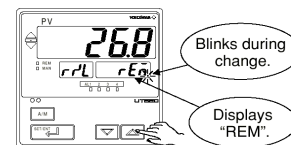

5. Press the **SETPOINT** key once to register the setpoint.

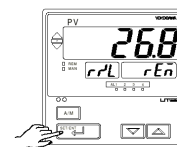

Automatically return to the display shown at power-on (figure below).

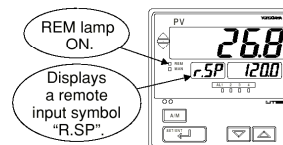

Figure 10 - Remote/Local Setting

4.6 Manipulating Control Output during Manual Operation



**NOTE**

Control output cannot be changed if the controller is stopped. In this case, the preset output value (operating parameter PO) will be output.

A control output value is linked with a display value changed using the or key. Note that the control output changes as displayed without requiring the key.

1. Bring manual operating display into view. For switching to manual operation, see “3.8 Switching between AUTO and MAN.”

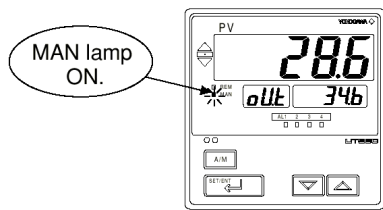

2. Press the or key to change a control output value. You don't need to press the key.

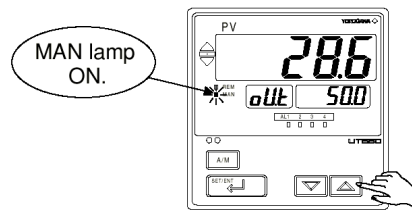

Figure 11 - Manual Output Control

Section 5.0 Controller Parameters

5.1 Getting to Controller Parameters

There are two sets of parameters that need to be set in this unit; Operating and Setup. To get to either set, start by completing steps 1 and 2 below. Use the up and down arrows to select between the Operating (oP.PR) or Setup (StUP) parameter sets.

1. Bring the operating display into view (display appears at power on).

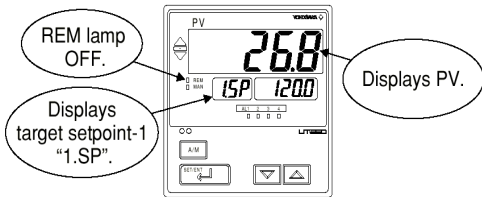

2. Press the key for more than 3 seconds to call up the menu “OP.PA”.

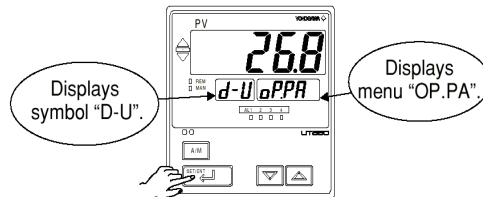

Figure 12 - Setting Controller Parameters

**5.2 Operating Parameter Flow Chart**

This is a general flow rate for the Operating Parameters; see the tables below to see the specific parameters needed for this particular controller.

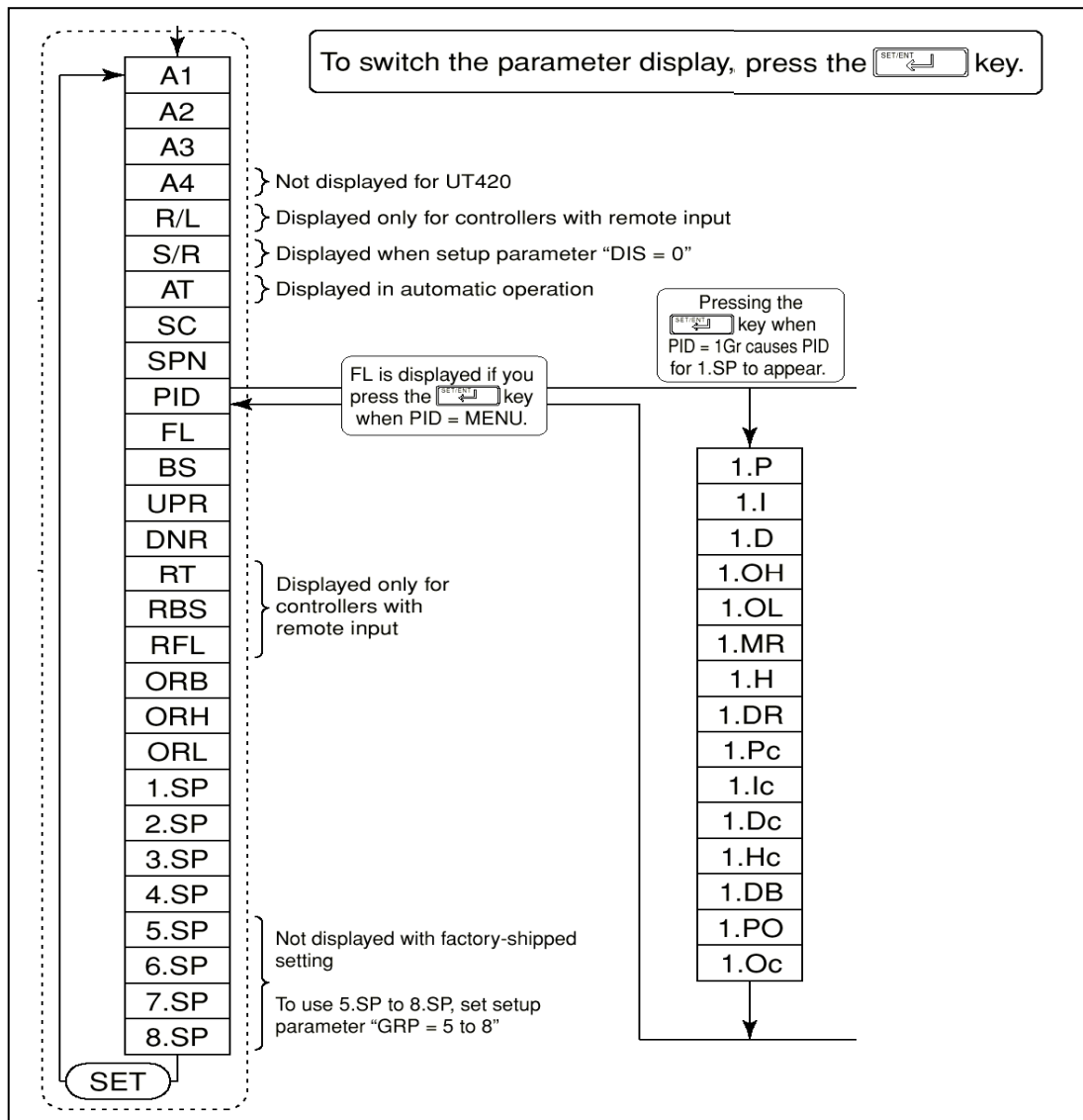

Figure 13 - Operating Parameter Flow

5.3 Setup Parameter Flow Chart

This is a general flow rate for the Setup Parameters; see the tables below to see the specific parameters needed for this particular controller.

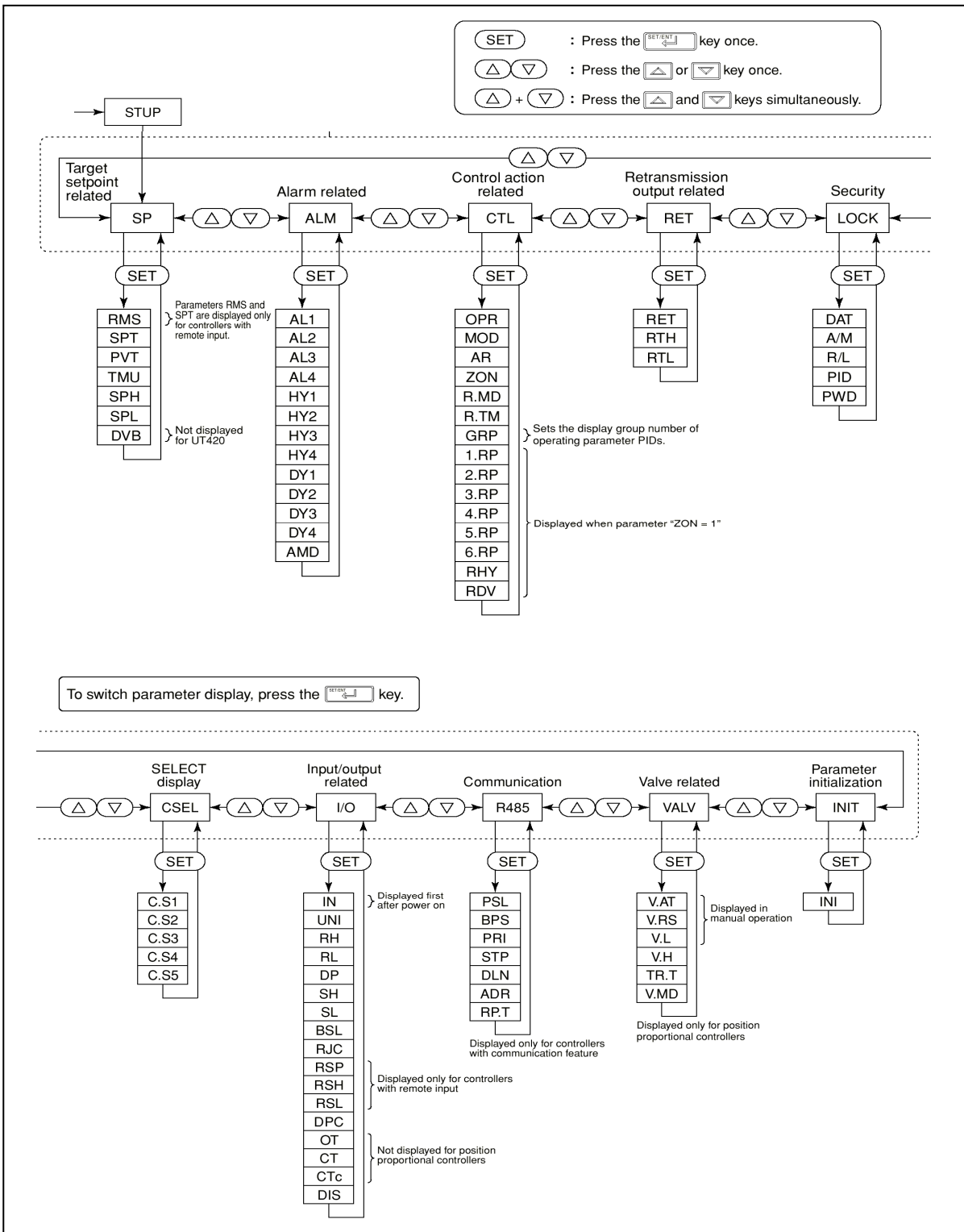

Figure 14 - Set Up Parameter Flow

**5.3.1 Speed Controller Operating Parameters**

Operating parameters and settings used in speed control

Display	Value	Desc.
<b>A1</b>	100.0	Alarm 1 Set Point - Project Specific
<b>A2</b>	0.0	Alarm 2 Set Point - Project Specific
<b>A3</b>	100.0	Alarm 3 Set Point - Project Specific
<b>A4</b>	0.0	Alarm 4 Set Point - Project Specific
<b>r/l</b>	LCL	Local/Remote
<b>SC</b>	oFF	"Super" Function
<b>SPn</b>	1	Target Setpoint number selection
<b>Pid</b>	1GR	PID Parameters, Will get mEnU initially, Press Up Button to get 1Gr, see below for PID set up
<b>FL</b>	oFF	PV Input Filter
<b>bS</b>	0.0	PV Input Bias
<b>UPr</b>	oFF	Setpoint ramp-up rate
<b>dnr</b>	oFF	Setpoint ramp-down rate
<b>rt</b>	1.000	Ratio Setting
<b>rbS</b>	0.0	Remote Input Bias
<b>rFL</b>	oFF	Remote Input Filter
<b>orb</b>	1.0	ON/OFF Rate Detection Band
<b>orH</b>	100.0	ON/OFF Rate High Limit
<b>orL</b>	0.0	ON/OFF Rate Low Limit
<b>1.SP</b>	Do not Change	Target setpoint 1

PID parameters used for 1.GR noted above. (May need to set values based on application)

	Display	Value	Desc.
<b>PID Parameters</b>	<b>1.P</b>	5.0	Proportional band
	<b>1.I</b>	240	Integral Time
	<b>1.d</b>	oFF	Derivative Time
	<b>1.oH</b>	100.0	Output High Limit
	<b>1.oL</b>	0.0	Output Low Limit
	<b>1.nr</b>	50.0	Manual Reset
	<b>1.dr</b>	RVS	Direct/Reverse Action Switch
	<b>1.Po</b>	0.0	Preset Output

**5.3.2 Speed Controller Setup Parameters**

	Display	Value	Desc.
<b>Set Point Related (SP)</b>	<b>SPt</b>	on	SP tracking selection
	<b>PVt</b>	off	PV tracking selection
	<b>TnU</b>	HoUr	Ramp-rate time unit
	<b>SPH</b>	100.0	Target Setpoint limiter upper limit
	<b>SPL</b>	0.0	Target Setpoint limiter lower limit
	<b>dvb</b>	1.0	Deviation display band

	Display	Value	Desc.
<b>Alarm Related (Alm)</b>	<i>AL1</i>	1	Alarm 1 Type - Project Specific
	<i>AL2</i>	2	Alarm 2 Type - Project Specific
	<i>AL3</i>	1	Alarm 3 Type - Project Specific
	<i>AL4</i>	2	Alarm 4 Type - Project Specific
	<i>HY1</i>	0.5	Alarm-1 Hysteresis - Project Specific
	<i>HY2</i>	0.5	Alarm-2 Hysteresis - Project Specific
	<i>HY3</i>	0.5	Alarm-3 Hysteresis - Project Specific
	<i>HY4</i>	0.5	Alarm-4 Hysteresis - Project Specific
	<i>dy1</i>	0.0	Alarm-1 Delay timer - Project Specific
	<i>dy2</i>	0.0	Alarm-2 Delay timer - Project Specific
	<i>dy3</i>	0.0	Alarm-3 Delay timer - Project Specific
	<i>dy4</i>	0.0	Alarm-4 Delay timer - Project Specific
	<i>And</i>	0	Alarm mode - Project Specific
<b>Control Action Related (Ctl)</b>	<i>oPr</i>	oFF	Output Velocity limiter
	<i>nod</i>	0	Output Velocity Limiter
	<i>Ar</i>	AUTO	Anti-Reset Windup (Excess Integration Prevent)
	<i>Eon</i>	0	Zone PID Selection
	<i>r.nd</i>	Cont	Reset mode
	<i>r.tn</i>	0	Restart timer
	<i>GRP</i>	1	PID group number
<b>Retransmission Output Related (rEt)</b>	<i>rEt</i>	1	Retransmission output type
	<i>rH</i>	100.0	Maximum value of retransmission output scale
	<i>rL</i>	0.0	Minimum value of retransmission output scale
<b>Security (LoCk)</b>	<i>dAt</i>	oFF	Front Panel Data setting Key Lock
	<i>A/n</i>	oFF	Front Panel A/M Key lock
	<i>A/L</i>	oFF	Lock of Remote/Local Selection Parameter
	<i>PId</i>	oFF	Lock of parameter PID Parameter display numbers
	<i>PuD</i>	0	Password setting
<b>SELECT display (CSEL)</b>	<i>C.S1</i>	oFF	Select Display-1 registration
	<i>C.S2</i>	oFF	Select Display-2 registration
	<i>C.S3</i>	oFF	Select Display-3 registration
	<i>C.S4</i>	oFF	Select Display-4 registration
	<i>C.S5</i>	oFF	Select Display-5 registration
<b>Input/Output related (I/o)</b>	<i>In</i>	41	PV Input Type 1-5 Volts (40 - 0.4 -2 Volts)
	<i>Unl</i>	%	PV Input Units (%)
	<i>rH</i>	5.000	Maximum Value of PV Input Range
	<i>rL</i>	1.000	Min. Value of PV Input Range
	<i>dP</i>	1	PV input Decimal Point
	<i>SH</i>	100.0	Max. Value of PV input scale
	<i>SL</i>	0.0	Min. Value of PV input Scale
	<i>bSL</i>	oFF	PV Input Burnout Action
	<i>rJC</i>	oFF	PV Input Reference Junction Compensation
	<i>rSP</i>	41	Remote Input type
	<i>rSH</i>	100.0	Maximum Value of remote input scale
	<i>rSL</i>	0.0	Minimum Value of remote input scale
	<i>ot</i>	2	Controller Output Type (Current Output)
	<i>Ct</i>	30	Control Output Cycle time
	<i>dI S</i>	1	DI function selection
<b>Parameter Initialization</b>	<i>I nl</i>	oFF	Parameter Initialization

Section 6.0 Maintenance

6.1 Troubleshooting Flow

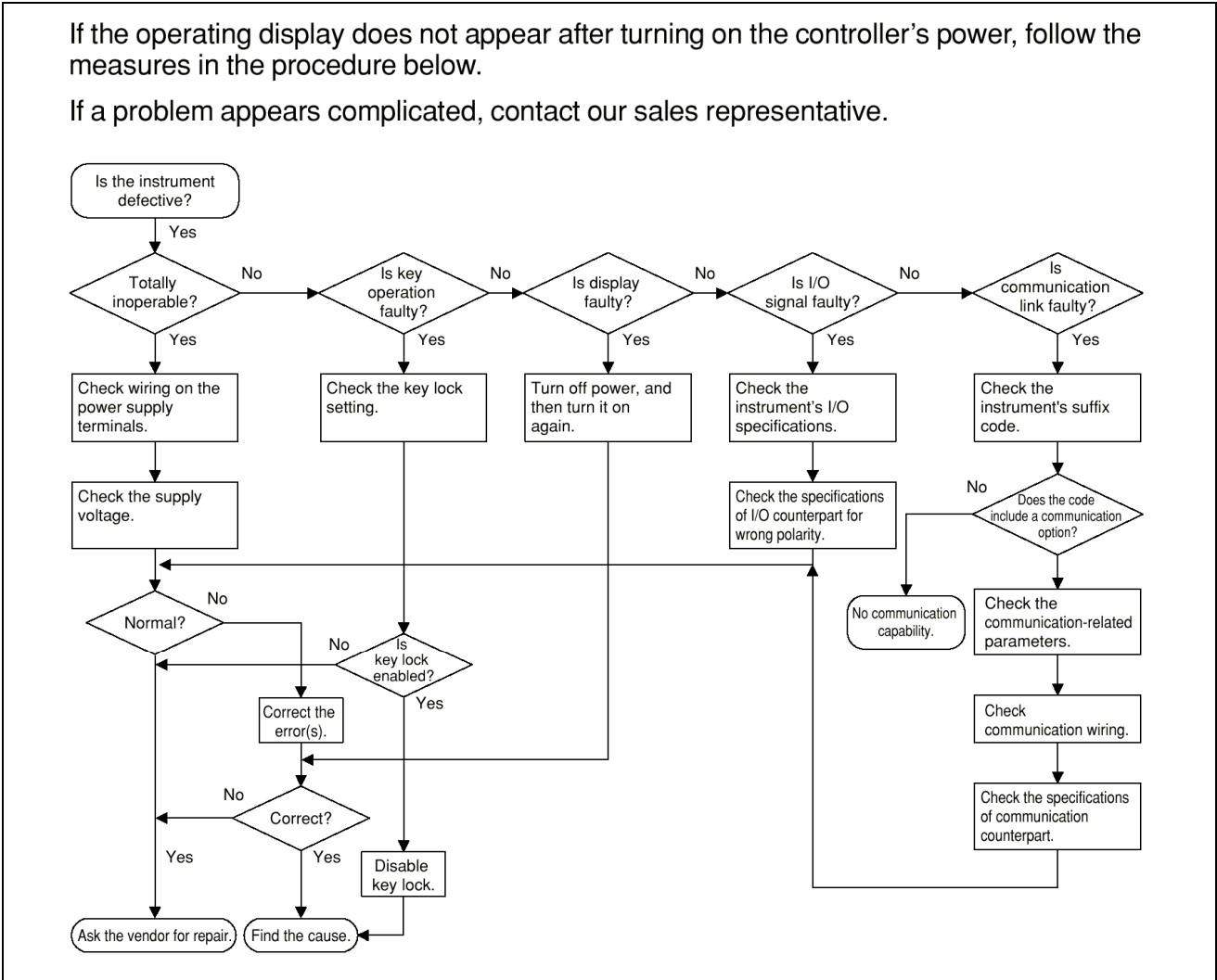



Figure 15 - Trouble Shooting Guide

6.2 Errors at Power On

The following table shows errors that may be detected by the fault diagnosis function when the power is turned on.

Error indication (on PV display unit)	Description of error	PV	Control output	Alarm output	Retransmission output	Communication	Remedy
<b>E000</b> (E000)	Faulty RAM	None	0% or less or OFF	OFF	0% or less	Stopped	Faulty Contact us for repair.
<b>E001</b> (E001)	Faulty ROM			Undefined	Undefined	Normal action	
<b>E002</b> (E002)	System data error	Undefined	Undefined	Undefined	Undefined		
PV decimal point blinks. 	Faulty calibration value	Normal action (out of accuracy)	Normal action (out of accuracy)	Normal action (out of accuracy)	Normal action (out of accuracy)	Normal action	Check and set the initialized parameters.
Error code (Note) (See description below.)	Parameter error	Normal action	0% or less or OFF	Normal action	Normal action	Normal action	

Note: An error code is displayed on the setpoint display unit.

An error code is displayed in the event of an error, according to its type.

An error code is a two-digit figure in which a combination of 6 bits of on and off is converted into a decimal number.

The following shows the relationship between each bit and parameter to be checked for abnormality.

Bit No.	6	5	4	3	2	1	0
Parameter to be checked	Operation mode/output	Operating parameters	Setup parameters	Range data	–	–	Calibration data

For example, if an error occurs with the operating parameter and calibration data, the error code will be as follows:

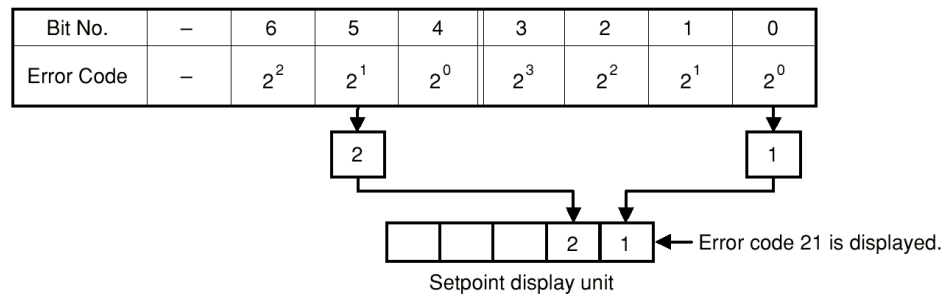

Figure 16 - Power Up Errors

6.3 Possible Errors During Operation

The following shows possible errors occurring during operations.

Error indication (on PV display unit)	Description of error	PV	Control output	Alarm output	Retransmission output	Communication	Remedy
Displays "RJC" and PV alternately	RJC error	Measured with RJC=0	Normal action				Faulty Contact us for repair.
Decimal point of item part in SP display unit blinks.	EEPROM error	Normal action					
<b>E300</b> (E300)	ADC error	105%	In AUTO: Preset value output In MAN: Normal action		Normal action		Check wires and sensor.
<b>boUt</b> (B.OUT)	PV burnout error	Dependent on the BSL parameter Up-scale: 105% Down-scale: -5%					
<b>oBEr</b> (OVER) or <b>-oBEr</b> (-OVER)	Excessive PV Out of -5 to 105%	-5% or 105%	Normal action	Normal action		Normal action	Check process.
<b>E200</b> (E200)	Auto-tuning failure (Time-out)	Normal action	Action with PID existing before auto-tuning				Check process. Press any key to erase error indication.
Setpoint display unit - - - - -	Feedback resistor breakdown		Normal action	Stopped	Stopped		
Left end of SP display unit blinks.	Faulty communication line	Normal action		Normal action			
Decimal point at right end lights. <input type="text"/> <input type="text"/> <input type="text"/> <input type="text"/> <input checked="" type="text"/>	Runaway (due to defective power or noise)	Undefined	0% or less or OFF	OFF	0% or less	Stopped	Faulty if power off/on does not reset start the unit. Contact us for repair.
All indications off	Power off	None					Check for abnormal power.

Figure 17 - Operational Errors

**6.4 Remedies if Power Failure Occurs During Operations**

The operation status and remedies after a power failure differ with the length of power failure duration:

- Instantaneous Power Failure of 20 ms or less  
A power failure is not detected. Normal operation continues.
- Power Failure of about 2 seconds or less

The following show effects caused in “settings” and “operation status.”

Alarm action	Continues. Alarm with standby function will enter standby status.
Setting parameter	Set contents of each parameter are retained.
Auto-tuning	Cancelled.
Control action	Action before power failure continues.

- Power failure of more than about 2 seconds

The following show effects caused in “settings” and “operation status.”

Alarm action	Continues. Alarm with standby function will enter standby status.								
Setting parameter	Set contents of each parameter are retained.								
Auto-tuning	Cancelled.								
Control action	Differs with setting of setup parameter “R.MD” (restart mode).								
	<table border="1"> <tr> <td>R.MD setting</td> <td>Control action after recovery from power failure</td> </tr> <tr> <td>CONT</td> <td>Action before power failure continues. (factory-shipped setting)</td> </tr> <tr> <td>MAN</td> <td>Outputs preset output value (PO) as control output and continues action set before power failure in MAN mode.</td> </tr> <tr> <td>Auto</td> <td>Outputs preset output value (PO) as control output and continues action set before power failure in AUTO mode.</td> </tr> </table>	R.MD setting	Control action after recovery from power failure	CONT	Action before power failure continues. (factory-shipped setting)	MAN	Outputs preset output value (PO) as control output and continues action set before power failure in MAN mode.	Auto	Outputs preset output value (PO) as control output and continues action set before power failure in AUTO mode.
	R.MD setting	Control action after recovery from power failure							
	CONT	Action before power failure continues. (factory-shipped setting)							
	MAN	Outputs preset output value (PO) as control output and continues action set before power failure in MAN mode.							
Auto	Outputs preset output value (PO) as control output and continues action set before power failure in AUTO mode.								
For heating/cooling control, preset output value is 50% of PID computation.									

**Figure 18 - Power Failure Error Remedies**

## 6.5 Troubleshooting when the Controller Fails to Operate Properly

If your control tasks are not successful, check the preset parameters and controller wiring before concluding the controller to be defective. The following show some examples of troubleshooting you should refer to in order to avoid the possibility of other problems.

### 6.5.1 The Controller Does Not Show the Correct Process Variable (PV)

- The UT420/UT450 controllers have a universal input. The type of PV input can be set/changed using the parameter "IN". At this point, the controller must be wired correctly according to the selected type of PV input.
- Check the wiring first if the controller fails to show the correct PV value. To do this, refer to "2. Initial Settings."
- With the parameters "RH", "RL", "DP", "SH" and "SL", it is possible to scale the input signal and change its number of decimal places. Also check that these parameters are configured correctly.

### 6.5.2 The Controller Does Not Provide Any Control Output or the Control Output Does Not Change at All

- The UT450/UT420 controllers have a universal output. The type of control output can be set/changed using the parameter "OT". At this point, the controller must be wired correctly according to the selected type of control output.
- Check the wiring first if the controller provides no control output. To do this, refer to "Figure 4 - Speed Control application wiring" on page 8.
- With the parameters "OH" and "OL", it is possible to set/change the high and low limits of control output. The control output may not change at all, however, because of restrictions on these parameters. Also check the restrictions on these parameters.
- The control output can only be changed when the controller is in the MAN mode. If the MAN lamp is off (i.e., the controller is in the AUTO mode), you cannot change the control output using key operation.

### 6.5.3 The Control Output Does Not Change Soon After the Target Setpoint (SP) Has Been Changed

- If this happens, check the setpoint of the parameter "MOD". In cases where fixed-point control is selected as the PID control mode (MOD = 1), tracking based on the I-term works to prevent the control output from changing suddenly even if the target setpoint SP is varied.
- The control output therefore may appear to be working incorrectly at first; however it gradually adapts itself to the new target setpoint. Be especially careful when the controller is in the fixed-point control mode; the control output may fail to change and therefore result in a loss of control if you change the target setpoint SP too frequently.

**Section 7.0 Parts Reference****7.1 Replacement Parts**

The service life given in the table below assumes that the controller is used under normal operating conditions.

Part	Service Life
Aluminum electrolytic condenser	About 10 years (rated)
EEPROM	About 100,000 times of writings
Alarm output relays	About 100,000 more ON-OFF operations or with resistance load
Control output relays	About 100,000 more ON-OFF operations or with resistance load

If any of these parts, except control output relays, cause a controller failure due to deterioration, contact your dealer for replacement at your cost. Control output relays can be replaced by yourself.

The following parts have a limited service life:

**7.2 Bran+Luebbe Parts**

Component	Part Number
Controller - Yokogawa UT450-04	008881B

**Section 8.0 Wiring terminal changes for converting UT35 to UT450 Installation**

		UT 35 Connection	UT 450-04 Connection
Remote Setpoint (4-20 ma)	+	6	21
	-	5	22
Retransmit Speed Output (4-20 ma)	+	11	14
	-	12	15
Remote/Local Select		8	28
		9	30
Stop/Run Select		13	18
		9	20
Power (100-240V AC, 50/60 HZ)	L	31	8
	N	25	9
	G	36	10
Control Output (4-20 ma)	+	22	16
	-	23	17

## Section 9.0 Quick Set Up for Speed Controller

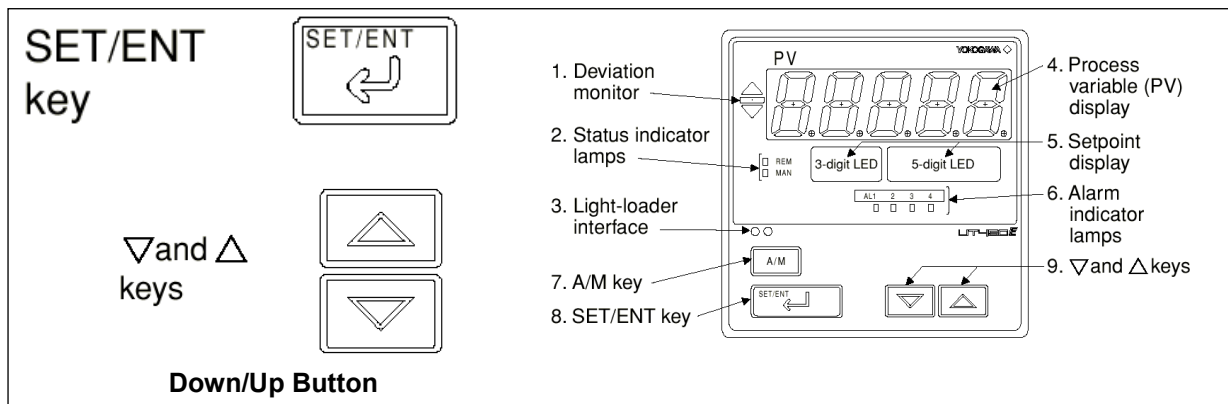

Figure 19 – Controller Face Quick Set Up

## 9.1 Process for setting the parameters on the Yokogawa UT450 Speed Controller

1. To enter the mode to set the controller parameters:
  - Press the Set/Ent key for about 3-5 seconds, the 3 digit LED display will show d-U and the 5 digit LED will show **oP.PA**.
2. To select between the Operating (oP.PA in 5 digit LED display) and Set Up (StUP in 5 digit LED display) Parameters use the Down/Up Button
3. To calibrate the controller to the actuator, the controller must be in manual before shifting to the Set Up Parameters mode. Go to the Valv parameter set and change the value of VAT to on and press the Set/Ent Key. The controller will move the actuator to 0 % then to 100% to calibrate the controller to the feedback potentiometer. Do not make any additional changes until the display returns to oFF.
4. When a parameter has been changed, a red dot will flash. To enter the parameter, press the Set/Enter Key. The red dot will either stop flashing or disappear.
5. To set the Operate Parameters:
  - Have **oP.PA** in 5 digit LED display
  - Press the Set/Enter Key to step down the menu for the Operate Parameters. If a change to a parameter is to be made, use the Down/Up Key to get the correct parameter then press the Set/Enter Key to enter the value.
6. To set the PID parameters in the operate parameter stack
  - When the PId appears in the 3 digit LED display (**mEnU** will appear in the 5 digit LED display), press the UP Button, this will display 1Gr in the 5 digit LED display. If the Down Button is pressed, the display will return to the Operate Parameters Stack (mEnU).
  - Press the Set/Enter Key to step through the PID parameters, changing any parameters by using the Down/Up Key then entering the value using the Set/Enter Key.
  - The other PID controls are note used so the xGr parameter settings are not covered here.
  - When mEnU reappears in the 5 digit LED display, all the PId parameters have been viewed. Press the Set/Enter Key to continue setting the Operate Parameters or reenter the PID parameters by pressing the UP Button.

The controller will continue to cycle through the Operate Parameters. To exit, press the Set/Enter Key and hold for about 5 seconds. 1.SP will appear in the 3-Digit LED display indicating the controller is back in the operate mode.

7. To set the Setup Parameters

- Have **StUP** in 5 digit LED display
- Use the Down/Up Key to move between parameter sets (SP, ALm, CtL, rEt, LoCK, CSEL, I/o, r485, VALV , and InIt) within the Setup Parameter stack. d-U will display in the 3-Digit LED display until one of the parameter stacks is entered.
- When at the desired set, press the Set/Enter Key to move through the selection.
- To change a parameter, use the Down/Up Key then when the desired parameter is entered, press the Set/Enter Key to save the value.
- When the d-U appears in the 3 digit LED display, the group of parameters has been completed.
- Use the Down/Up Key to move between parameter sets within the Setup Parameter stack.

9.2 Speed Controller Operating Parameters

Operating parameters and settings used in speed control

Display	Value	Desc.
<b>A1</b>	100.0	Alarm 1 Set Point - Project Specific
<b>A2</b>	0.0	Alarm 2 Set Point - Project Specific
<b>A3</b>	100.0	Alarm 3 Set Point - Project Specific
<b>A4</b>	0.0	Alarm 4 Set Point - Project Specific
<b>r/l</b>	LCL	Local/Remote
<b>SC</b>	oFF	"Super" Function
<b>SPn</b>	1	Target Setpoint number selection
<b>PId</b>	1GR	PID Parameters, Will get mEnU initially, Press Up Button to get 1Gr, see below for PID set up
<b>FL</b>	oFF	PV Input Filter
<b>bS</b>	0.0	PV Input Bias
<b>UPr</b>	oFF	Setpoint ramp-up rate
<b>dnr</b>	oFF	Setpoint ramp-down rate
<b>rt</b>	1.000	Ratio Setting
<b>rbS</b>	0.0	Remote Input Bias
<b>rFL</b>	oFF	Remote Input Filter
<b>orb</b>	1.0	ON/OFF Rate Detection Band
<b>orH</b>	100.0	ON/OFF Rate High Limit
<b>orL</b>	0.0	ON/OFF Rate Low Limit
<b>1.SP</b>	Do not Change	Target setpoint 1

PID parameters used for 1.GR noted above. (May need to set values based on application)

	Display	Value	Desc.
PID Parameters	<b>1.P</b>	5.0	Proportional band
	<b>1.I</b>	240	Integral Time
	<b>1.d</b>	oFF	Derivative Time
	<b>1.oH</b>	100.0	Output High Limit
	<b>1.oL</b>	0.0	Output Low Limit
	<b>1.nr</b>	50.0	Manual Reset
	<b>1.dr</b>	RVS	Direct/Reverse Action Switch
	<b>1.Po</b>	0.0	Preset Output

## 9.3 Speed Controller Set Up Parameters

	Display	Value	Desc.
<b>Set Point Related (SP)</b>	<i>SPt</i>	on	SP tracking selection
	<i>PVt</i>	off	PV tracking selection
	<i>TnU</i>	HoUr	Ramp-rate time unit
	<i>SPH</i>	100.0	Target Setpoint limiter upper limit
	<i>SPL</i>	0.0	Target Setpoint limiter lower limit
	<i>dvb</i>	1.0	Deviation display band
<b>Alarm Related (Alm)</b>	<i>AL1</i>	1	Alarm 1 Type - Project Specific
	<i>AL2</i>	2	Alarm 2 Type - Project Specific
	<i>AL3</i>	1	Alarm 3 Type - Project Specific
	<i>AL4</i>	2	Alarm 4 Type - Project Specific
	<i>HY1</i>	0.5	Alarm-1 Hysteresis - Project Specific
	<i>HY2</i>	0.5	Alarm-2 Hysteresis - Project Specific
	<i>HY3</i>	0.5	Alarm-3 Hysteresis - Project Specific
	<i>HY4</i>	0.5	Alarm-4 Hysteresis - Project Specific
	<i>dy1</i>	0.0	Alarm-1 Delay timer - Project Specific
	<i>dy2</i>	0.0	Alarm-2 Delay timer - Project Specific
	<i>dy3</i>	0.0	Alarm-3 Delay timer - Project Specific
	<i>dy4</i>	0.0	Alarm-4 Delay timer - Project Specific
	<i>And</i>	0	Alarm mode - Project Specific
<b>Control Action Related (Ctl)</b>	<i>oPr</i>	oFF	Output Velocity limiter
	<i>nod</i>	0	Output Velocity Limiter
	<i>Ar</i>	AUTO	Anti-Reset Windup (Excess Integration Prevent)
	<i>Eon</i>	0	Zone PID Selection
	<i>r.nd</i>	Cont	Reset mode
	<i>r.tn</i>	0	Restart timer
	<i>GRP</i>	1	PID group number
<b>Retransmission Output Related (rEt)</b>	<i>rEt</i>	1	Retransmission output type
	<i>rtH</i>	100.0	Maximum value of retransmission output scale
	<i>rtL</i>	0.0	Minimum value of retransmission output scale
<b>Security (LoCk)</b>	<i>dAt</i>	oFF	Front Panel Data setting Key Lock
	<i>A/n</i>	oFF	Front Panel A/M Key lock
	<i>A/L</i>	oFF	Lock of Remote/Local Selection Parameter
	<i>PId</i>	oFF	Lock of parameter PID Parameter display numbers
	<i>PuD</i>	0	Password setting
<b>SELECT display (CSEL)</b>	<i>C.S1</i>	oFF	Select Display-1 registration
	<i>C.S2</i>	oFF	Select Display-2 registration
	<i>C.S3</i>	oFF	Select Display-3 registration
	<i>C.S4</i>	oFF	Select Display-4 registration
	<i>C.S5</i>	oFF	Select Display-5 registration

	Display	Value	Desc.
<b>Input/Output related (I/O)</b>	<i>In</i>	41	PV Input Type 1-5 Volts (40 - 0.4 -2 Volts)
	<i>Unl</i>	%	PV Input Units (%)
	<i>rH</i>	5.000	Maximum Value of PV Input Range
	<i>rL</i>	1.000	Min. Value of PV Input Range
	<i>dP</i>	1	PV input Decimal Point
	<i>SH</i>	100.0	Max. Value of PV input scale
	<i>SL</i>	0.0	Min. Value of PV input Scale
	<i>bSL</i>	oFF	PV Input Burnout Action
	<i>rJC</i>	oFF	PV Input Reference Junction Compensation
	<i>rSP</i>	41	Remote Input type
	<i>rSH</i>	100.0	Maximum Value of remote input scale
	<i>rSL</i>	0.0	Minimum Value of remote input scale
	<i>ot</i>	2	Controller Output Type (Current Output)
	<i>Ct</i>	30	Control Output Cycle time
	<i>dI S</i>	1	DI function selection
<b>Parameter Initialization</b>	<i>I nl</i>	oFF	Parameter Initialization

9.4 Controller Wiring

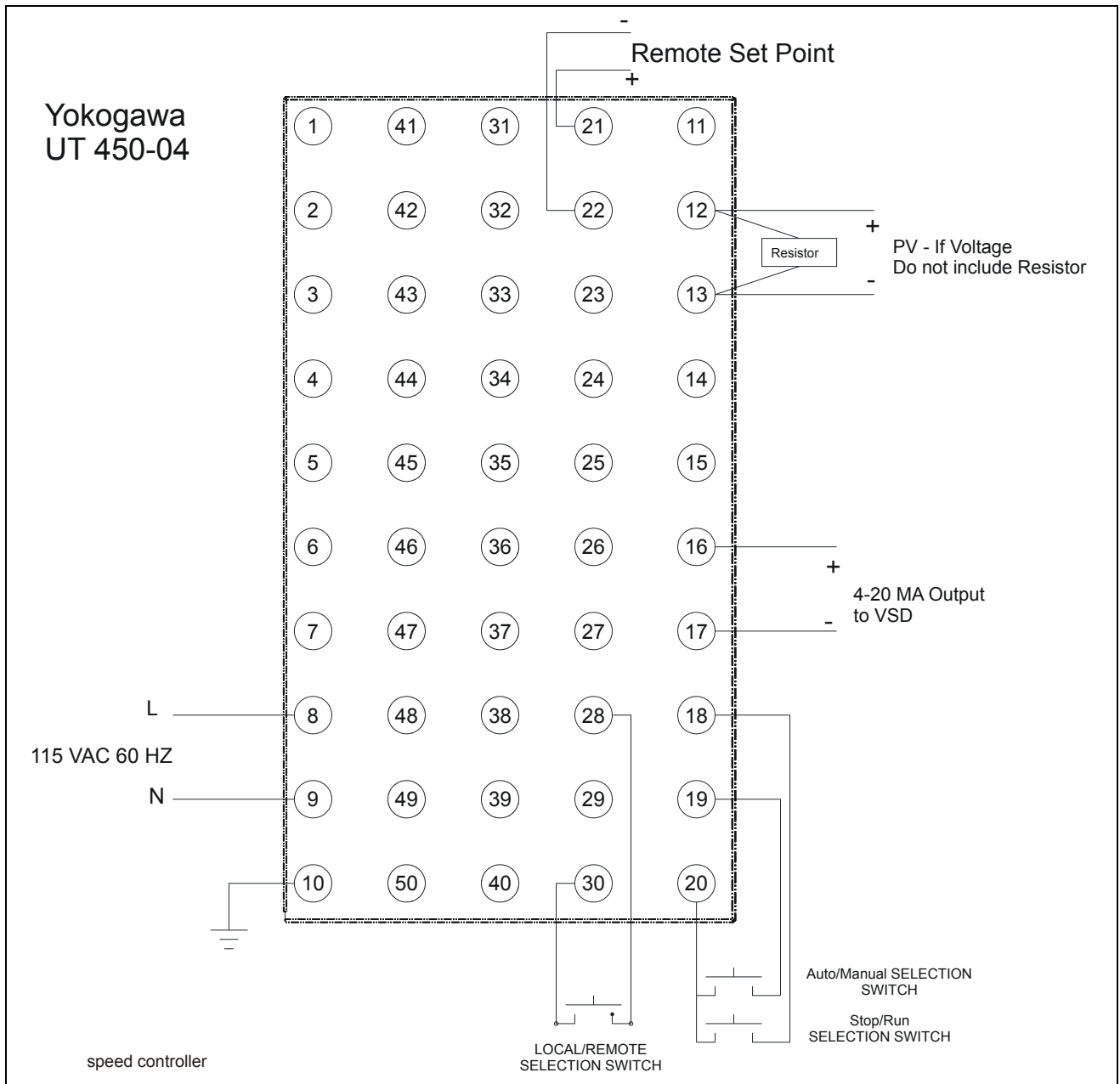

**Figure 20 - Speed Control application wiring.**

If Local/Remote, Auto/Manual or Stop/Run features are not needed - it is not necessary to wire a switch for that function.

The unit is set up for a 1-5 VDC process variable and remote setpoint (if used)