

AutoBlend Systems

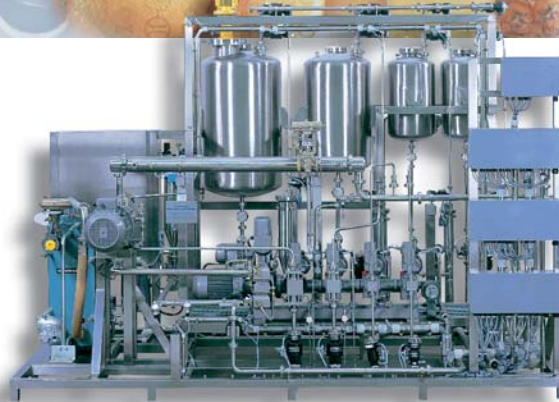

AutoBlend

The complete solution for higher productivity and product quality

Turn-key metering and blending systems for the production of high-value products using liquids, pastes and powders.

Our Focus: The Customer's Needs

Our dedicated systems engineers develop the best possible solutions for your needs, either from our extensive range of standard systems or individually designed and manufactured to your specification.

The wide range of proven key components manufactured by SPX Process Equipment means that installations are almost completely assembled from our own products - the accurate and reliable metering and process pumps, mixers

both in-line and tank mounted, homogenizers and computer-operated controllers. For Bran+Luebbe, a turn-key installation means just that. We take over everything, from design concept through project engineering, manufacture, installation, hardware and software for process control, to start up and operator training. You can rely on it.



Installation for the continuous manufacture of aerated confectionery products, including metering pumps and flow measuring system.

Reduce costs, increase quality

AutoBlend installations can dramatically improve productivity and reduce running costs. All Bran+Luebbe installations meet the highest standards of quality and reliability.

From conception to production, with the

- **Drinks**
 - Fruit Juice
 - Vitamin
 - Brandy
 - Vodka
 - Liqueurs
- **Food**
 - Margarine
 - Mayonnaise
 - Dressings
 - Sauces
 - Ketchup
 - Syrups
 - Confectionery
 - Chocolate
 - Yogurt
- **Cosmetics and Detergents**
 - Shampoo
 - Body Lotion
 - Household Cleaners
 - Fabric Softener
 - Liquid Soap and Detergent
 - Shoe Polish
 - Alkyl Ether Sulphate Solutions
 - Sulphonic Acid Neutralization
- **Chemicals**
 - Pulp and Paper
 - Textiles
 - Paints and Dyes
 - Chemical Solvents
 - Pharmaceuticals
 - Oil and Gas
- **Special Applications**
 - Water Treatment
 - Bitumen
 - Sewage Treatment



This 16-component installation produces 20 tons of liquid soap per hour. Computer-controlled automation includes recipe management, raw material usage and production reports. Flow monitoring ensures the highest possible accuracy.

Versatility and Flexibility

AutoBlend installations are used in all kinds of industries and processes - food, chemicals, cosmetics and pharmaceuticals, batch or continuous production, semi- or fully-automatic operation, single or multiple products. AutoBlend installations are made to measure.

Automation on Demand

Process control is at the heart of production management. Most AutoBlend installations employ fully automatic control, using Bran+Luebbe hardware and software tools adapted to the application.

In addition to straight forward control, other modules provide:

- Process Visualization
- Operating Protocol
- Recipe Management
- Data Storage
- Raw Material Management

The most basic type of system control monitors a single process. This can be extended to several processes, using a single computer with data-bus communication.

Even if the computer should fail, production need not be interrupted. All modules and functions can be controlled manually.



Production of lotion and detergent in parallel batch containers. Gravimetric control for primary components. Minor components are metered in from separate containers.

Batch or Continuous?

There is often no clear-cut answer to whether a particular process is better suited to batch or continuous production. Our experts can draw on Bran+Luebbe's wide experience of process automation to advise you. Some of the decision factors and advantages for each method are shown below.

Continuous Processes

For little variation in recipes:

- Just-in-time production
- Continuous product quality control
- Simplified procedure with step-by-step automation or fully automatic recipe management
- High flexibility
- Closed system - minimum risk of bacterial contamination
- High formula accuracy - savings in raw material
- Just-in-time production

- Optimized sterile-in-place (SIP) and clean-in-place (CIP) procedures
- High capacity with low space requirement

Batch Processes

For high variation in recipes:

- High flexibility
- Easy to control
- Simple procedure
- Highest precision
- Digital process monitoring and control
- CIP possible
- Integrated quality analysis



Continuous production of high-quality liqueur with multi-component metering and N-Form mixers.

AutoBlend Body Lotion Production

Type: Continuous production
Capacity: 300 GPH

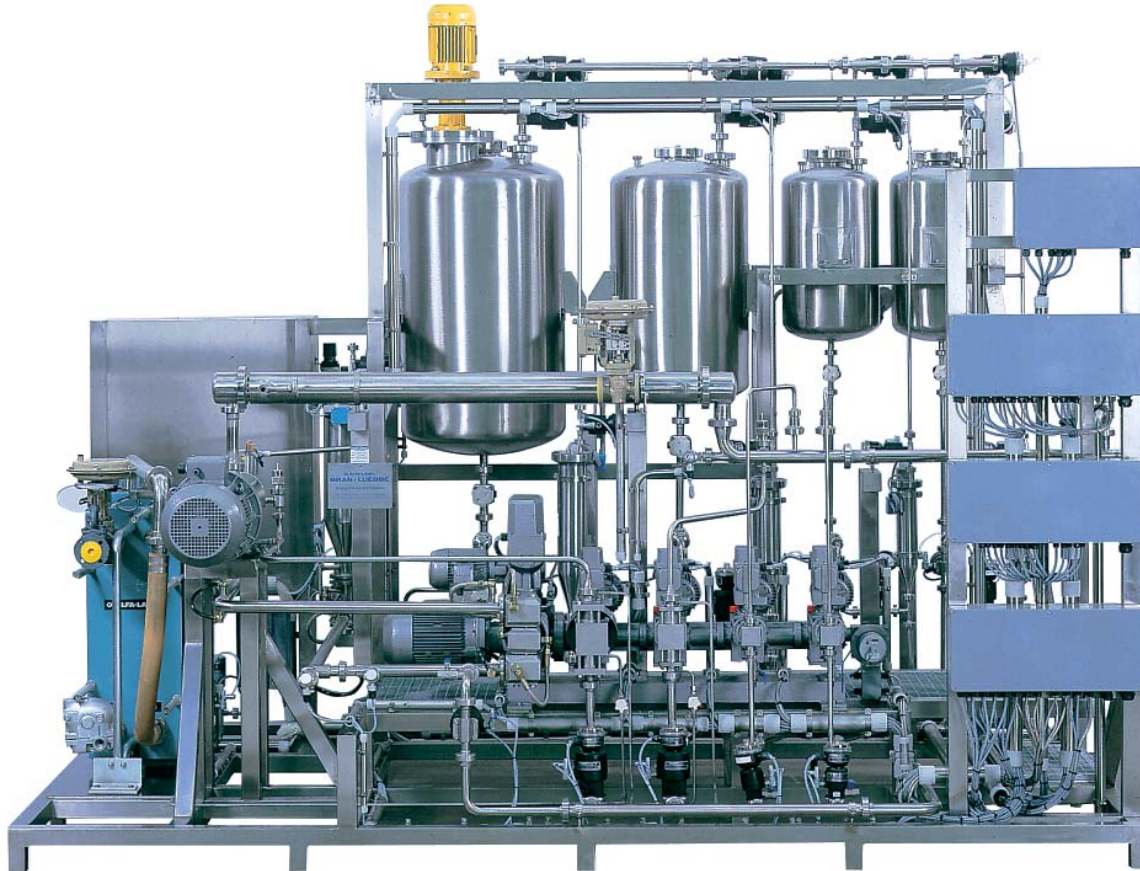

Metering and mixing system for body lotion

Continuous production of high quality body lotion with a Bran+Luebbe metering and mixing system. Emulsification with a Bran+Luebbe PENTAX mixer.

End-product cooling in a tube heat exchanger. Computer-controlled system with mass flow meters and flow stream monitoring. Aseptic design with CIP cleaning system.

Advantages

- Continuous production enables sterile operation and direct dispatch to the filling station
- No air introduction to finished product
- Constant product quality
- Flow-through cleaning and sterilization with automatic CIP-system

Packaging - Processing

Bid on Equipment

1-847-683-7720

www.bid-on-equipment.com

Components

- 1 Type H2 metering pump with electric delivery volume control plunger pump head
- 4 Type P metering pumps with electric delivery volume control, 4 plunger pump heads (1 pump head heated)
- 1 PENTEX dynamic mixer
- 3 pipe heat exchanger in sanitary design
- 1 on-line mass flowmeter
- 1 on-line pH-analyzer
- 1 on-line viscosity analyzer
- Automatic valves

Automation

- Fully automatic process control
- Recipe and product management with data report
- Automatic product monitoring with control loop
- Automatic shut-down if any ingredient runs out

Simplified Process Diagram

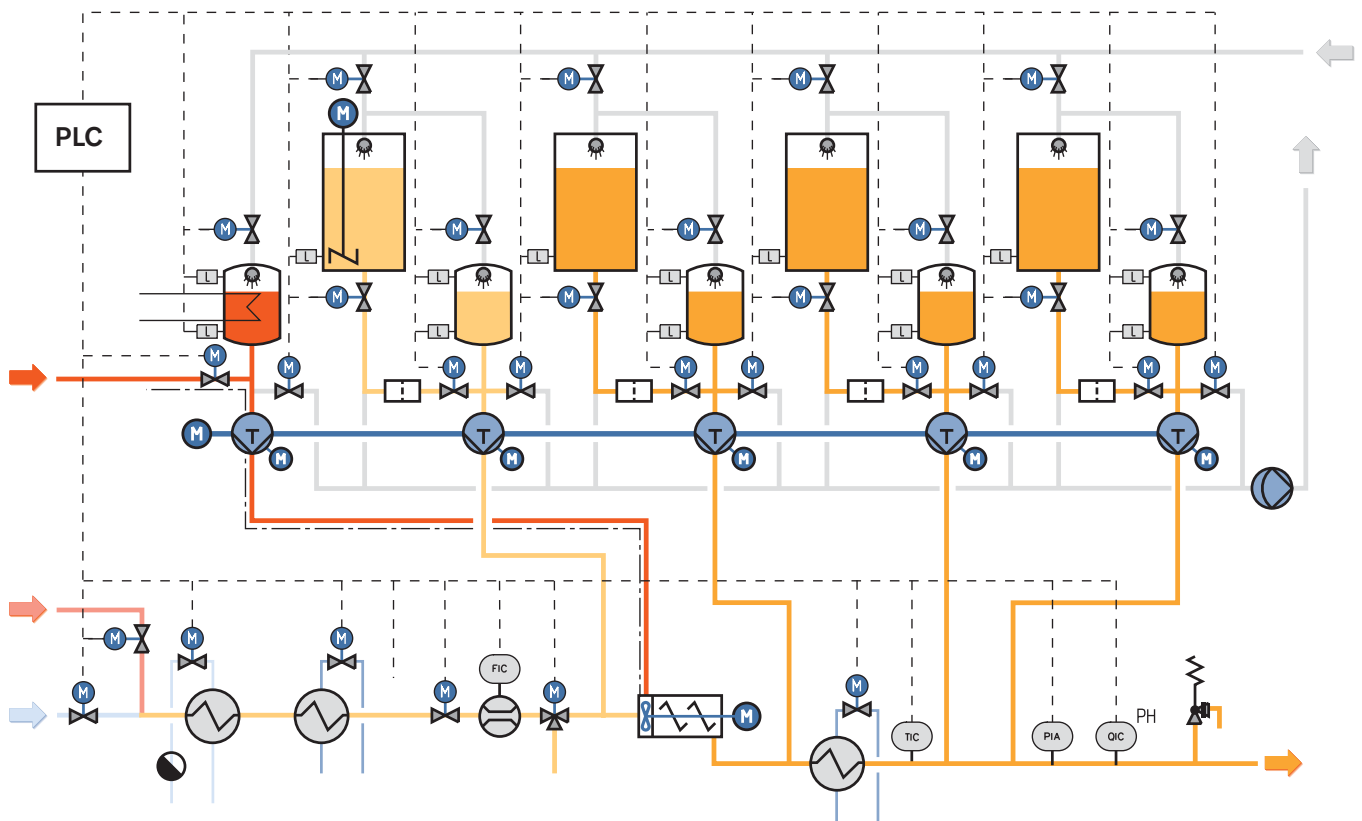

AutoBlend Shampoo Production

Type: Continuous production
Capacity: 4000 GPH

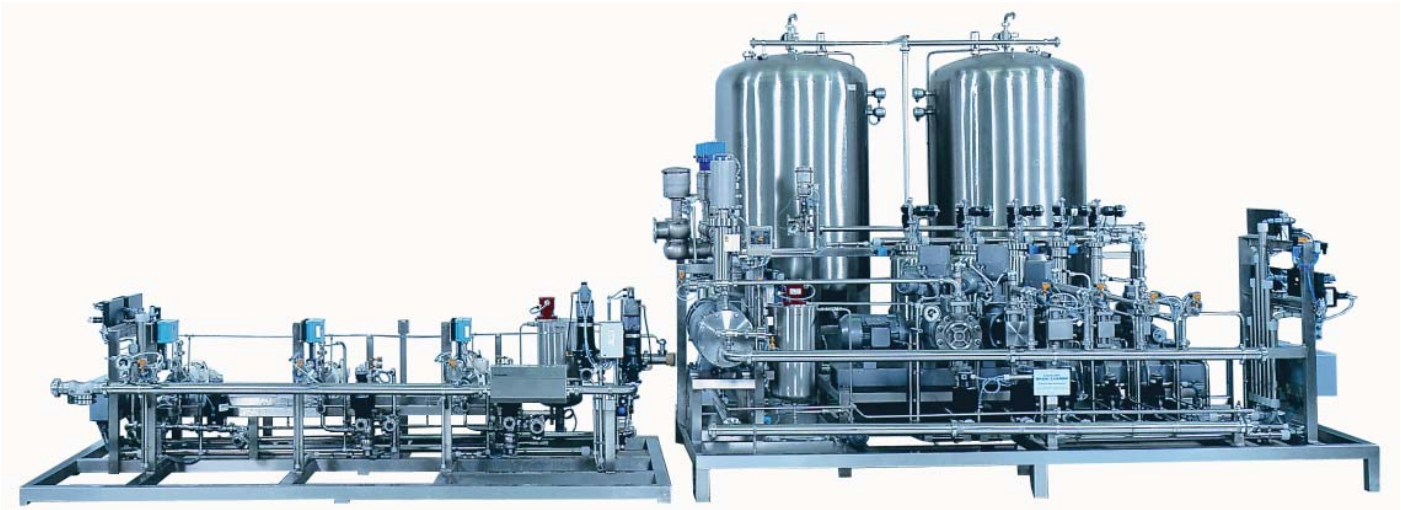

Metering and mixing system for shampoo

The AutoBlend shampoo installation was developed by Bran+Luebbe for the continuous production of cosmetics without preservatives.

The main components are delivered by rotary pumps with flow meters, the minor ingredients by metering pumps. The PENTAX mixer ensures a homogenous product.

The process runs fully automatically under a PLC, controller with recipe management, raw material management and process data reports. The installation satisfies the necessary hygienic requirements, and cleaning is automatic. The pH and viscosity of the finished product are measured on-line.

Advantages

- Continuous production enables sterile operation and direct dispatch to the filling station
- High capacity
- No air introduction to finished product
- Constant product quality
- Flow-through cleaning and sterilization with automatic CIP-system

Packaging - Processing

Bid on Equipment

1-847-683-7720

www.bid-on-equipment.com

Components

- 1 NOVADOS Type H4 metering pump
- 4 NOVADOS Type P metering pumps with electric delivery volume control
- 1 PENTEX dynamic mixer
- 1 on-line pH-analyzer
- 1 on-line viscosity analyzer
- 4 on-line mass flowmeters
- Rotary pumps, automatic valves etc.

Automation

- Fully automatic process control
- Automatic product monitoring with control loop
- Automatic shut-down if any ingredient runs out

Simplified Process Diagram

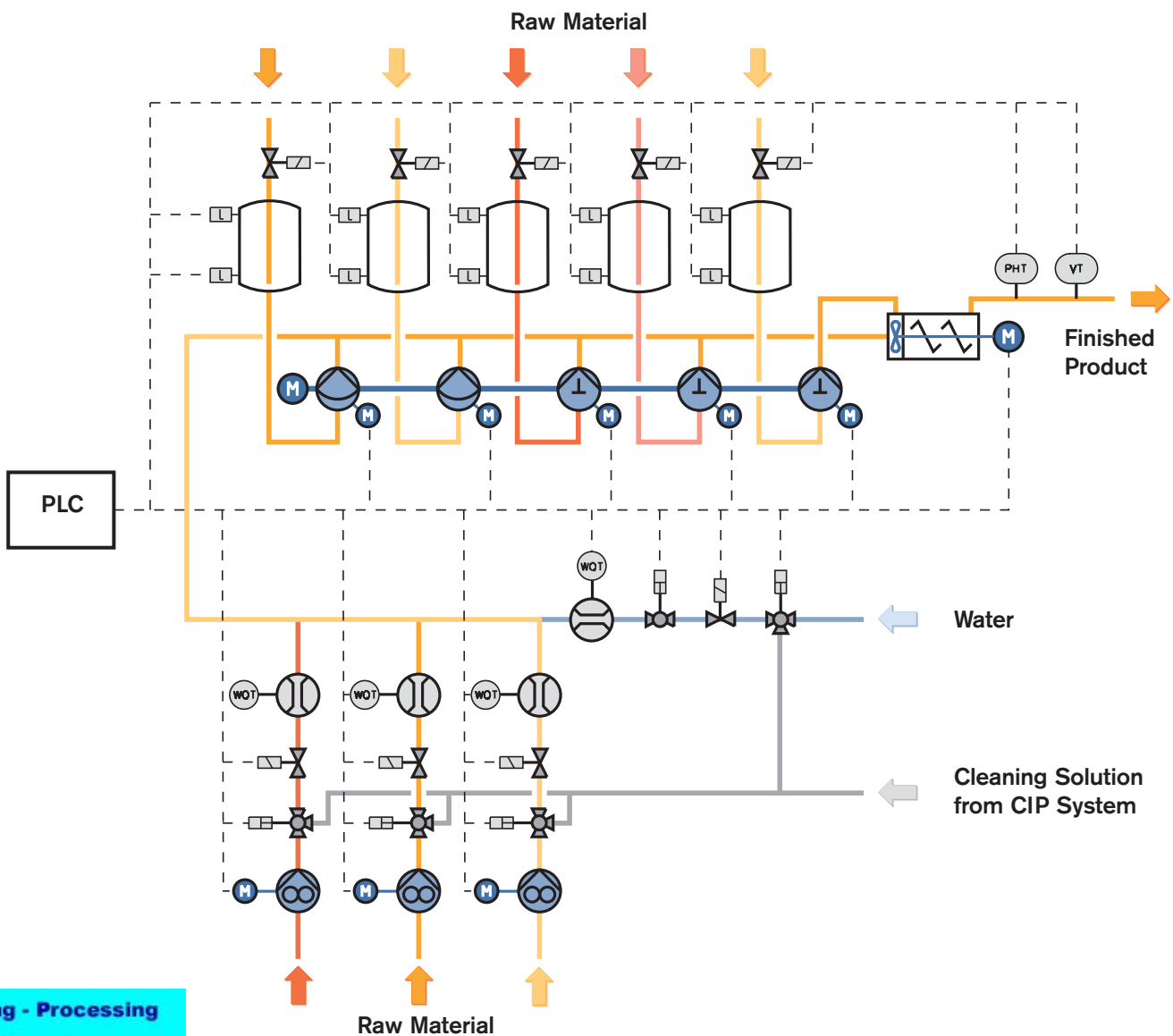

AutoBlend Dye System (Any Additive)

Type: Continuous production
Capacity: 32 GPH

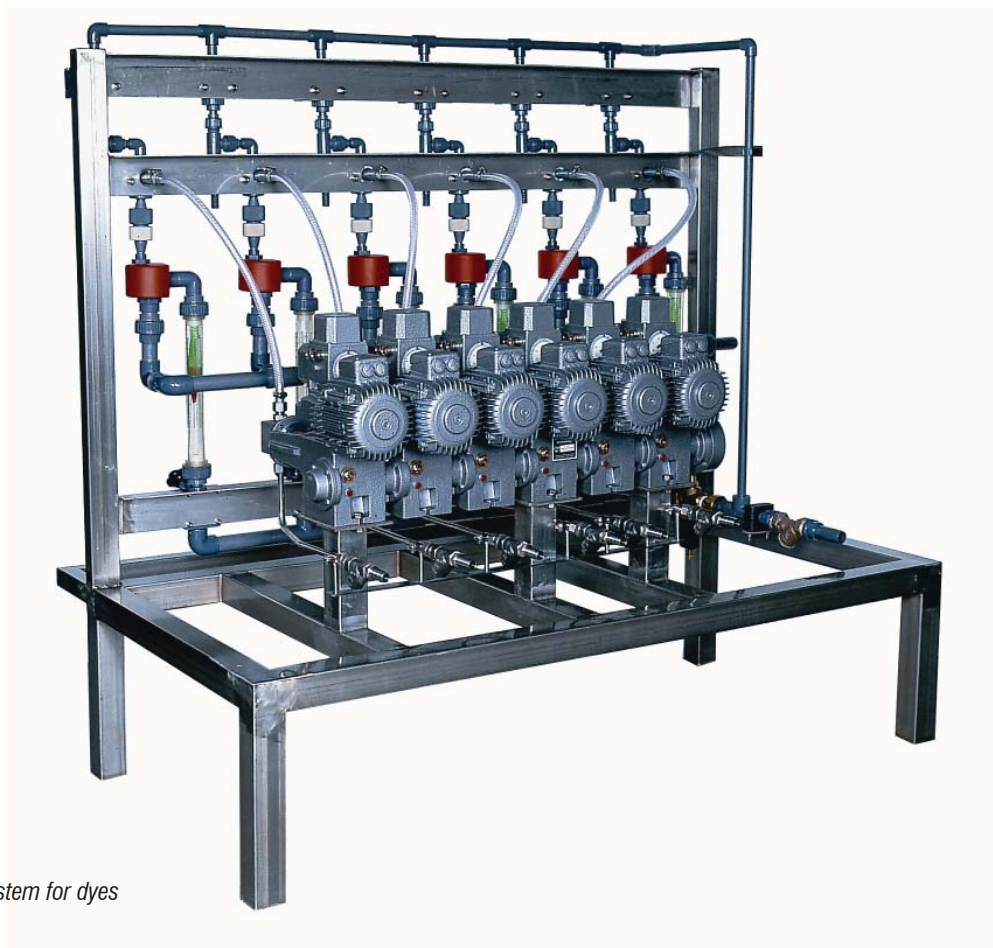

Metering and mixing system for dyes

This installation uses a metering pump with 6 pump heads. The proportion of each dye in the mixture is controlled by adjusting the pump stroke.

The motor speed is regulated proportionally to the speed of the paper production machine. The dye intensity can be adjusted by altering the ratio of the pump speed to the paper machine speed.

The dye mixture may be diluted with a high volume of water immediately after delivery, to simplify transport and mixing.

Automatic recipe adjustment can be provided by fitting electrically operated stroke length adjusters.

Advantages

- Continuous production enables direct dyeing
- Constant dye intensity
- Dyes can be metered directly out of their containers
- Cost is reduced compared to batch dyeing

Packaging - Processing

Bid on Equipment

1-847-683-7720

www.bid-on-equipment.com

Components

- 6 NOVADOS Type P metering pumps with electrical delivery, volume adjustment, 6 plunger pump heads
- 6 flow meters
- 6 valve mixers
- Variable speed drive motor

Automation

- Automatic shut-down if any ingredient runs out

Simplified Process Diagram

