



AN SPX BRAND

Complete Solutions for Liquid Filtration



Single Filter Multibasket 200mm (8")-250mm (10") Model OV

The Single Filter Multibasket extends the range of Single Filters, specially designed to be compact and easily maintained, with basket removal easier compared to other units with similar pipe size connections.

The filter is of cast construction and is supplied with four or five high quality stainless steel cylindrical baskets depending upon the size. For use in liquid handling installations where flow can be interrupted to allow the removal of baskets for cleaning.

Main Features

- High quality stainless steel baskets with large filtration areas resulting in low pressure drops.
- Compact design for space saving.
- Working pressures up to 13.8 bar.
- Quick release filter covers and knobs for easy basket removal.

Options

- Range of extras allowing filter to be customised.
- Available in cast iron, cast steel, bronze or stainless steel as standard.
- Differential pressure indicators are available.

Specification

MODEL	OV	OV/S	OV/GM	OV/SS
Body Material	Cast Iron BS EN1561/EN-JL 1030	Cast steel BS EN10213-2/1.0625	Gunmetal BS 1400-LG4C	BS 1504 316 C16
Cover Material	Cast Iron BS EN1561/EN-JL 1030	Cast steel BS EN10213-2/1.0625	Bronze BS1400-LG4C	BS 1504 316 C16
Maximum working pressure	13.8 bar at 50°C	13.8 bar at 50°C	13.8 bar at 50°C	13.8 bar at 50°C
Baskets	Stainless Steel — Basket & Mesh Lining BS1449 Grade 316 S31			
Drain plug	Brass	Stainless Steel	Gunmetal	Stainless Steel
Vent	Stainless Steel	Stainless Steel	Phosphor Bronze	Stainless Steel
Standard seals	Nitrile (-35°C to +120°C)	Nitrile (-35°C to +120°C)	Nitrile (-35°C to +120°C)	Viton (-20°C to +200°C)
Body colour	Blue	Silver	Self	Self

Please Note

- 1 These specifications refer to standard products only. Other materials for bodies (e.g. monel, hastalloy) and seals (e.g. EP, PTFE) are available on request.
- 2 Working pressure is stated at 50°C. To verify suitability of this equipment above this temperature or below 0°C, please contact our Technical Sales Team.
- 3 Whilst alternative seal materials e.g. EP, PTFE are available and can be used to offer a wide range of chemical compatibility and working temperatures up to 260°C, it is recommended that such applications are again discussed with our Technical Sales Team.

Equivalent Material Specifications

	Cast Iron	Cast Steel	Gunmetal	Stainless Steel	Bronze
European Standard	BS EN1561/EN-JL 1030	BS EN10213-2/1.0625	BS 1400 GRD LG4C	BS 1504 316 C16	BS 1400 GRD LG4C
American Standard	ASTM A48/76 Class 35	ASTM A216 Grade WCB	—	ASTM A351 CR8M	—

Size (sizes in mm)

	A	B	C	D	E1 E2	F	G	H	Weight (Cast Iron)
200 (8")	200	595	230	308	420 (E1)	658	610	381	260kg
250 (10")	250	595	276	272	600 (E2)	908	610	445	391kg

200mm (8") Filter — 4 Baskets

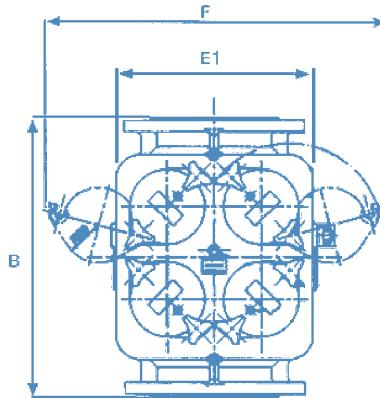
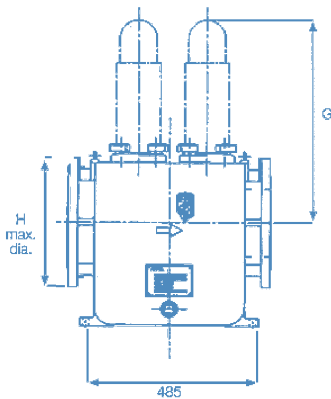

250mm (10") Filter — 5 Baskets

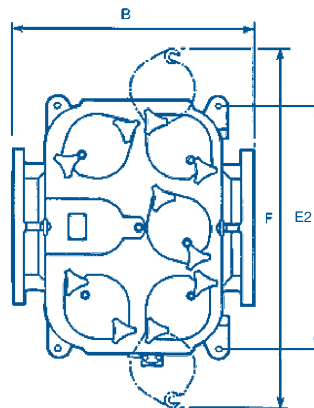
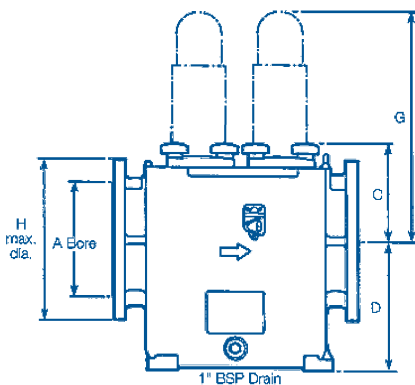

SPX[®]
FLOW CONTROL

SPX Flow Control
Hambridge Road
Newbury, Berkshire, RG14 5TR
Phone: +44 (0) 1635 263915 Fax: +44 (0) 1635 36006
E-mail: airpel@spx.com

Packaging - Processing
Bid on Equipment
1-847-683-7720
www.bid-on-equipment.com

For more information about our worldwide locations, approvals, certifications, and local representatives, please visit www.spxpe.com.

SPX reserves the right to incorporate our latest design and material changes without notice or obligation. Design features, materials of construction and dimensional data, as described in this bulletin, are provided for your information only and should not be relied upon unless confirmed in writing. Certified drawings are available upon request.