



Complete Solutions for Liquid Filtration

Self Cleaning Filter

High Pressure Range

Models 200HP, 300HP, 400HP, 600HP,
800HP, 1000HP, 1200HP

Sizes 40mm (1 1/2") - 300mm (12")

Manual & Automatic

The High Pressure range of self cleaning filters have been successfully applied in many difficult liquid handling installations throughout the world.

Main Features

- Continuous Filtration - No interruption to flow during cleaning process
- Minimal amount of liquid loss during cleaning process
- Suitable for practically all liquids including those of high viscosity
- Filtration levels down to 25 micron
- Integral cast construction
- Maximum working pressure 35 bar at 50°C
- Maximum working temperature 260°C (dependent on seal material)
- Available in cast iron, SG iron, cast steel, stainless steel or gun metal
- High quality 316 stainless steel wound wedge wire or perforated element

Options

- Range of automated control devices available
- Heating jackets

Please note

- 1 Working pressure is stated at 50°C. To verify suitability of this equipment above this temperature or below 0°C, please contact our Technical Sales Team.
- 2 Whilst alternative seal materials e.g. EP, PTFE are available and can be used to offer a wide range of chemical compatibility and working temperatures up to 260°C, it is recommended that such applications are again discussed with our Technical Sales Team.



Flanged Filters (sizes in mm)

Model	A Pipe Size	B	C	D	E	F	G	H	J	K	L	M	N	P	R	S	Weight Manual (kg)	Weight Auto (kg)
200	32(1 1/4") 50(2")	270	150	195	413	150	325	115	185	540	150	124	110	1"BSP	165	25	36kg	44kg
300	80(3")	360	210	230	560	180	430	140	185	575	180	124	142	2"BSP	210	22	60kg	68kg
400	100(4")	550	315	435	1115	340	665	235	285	880	332	—	142	2"BSP	254	30	164kg	On req.
600	150(6")	550	315	435	1550	340	1165	235	285	880	332	—	142	2"BSP	318	35	182kg	On req.

Models 800-1200 units are available as fabricated units comprising of multiple model 600 elements which are subject to process conditions. Please contact our Technical Sales Team for further information on these products.

* The Model 200, 32mm — 50mm size units, also available in screwed version. Larger sizes upon request.

Model 400, 600

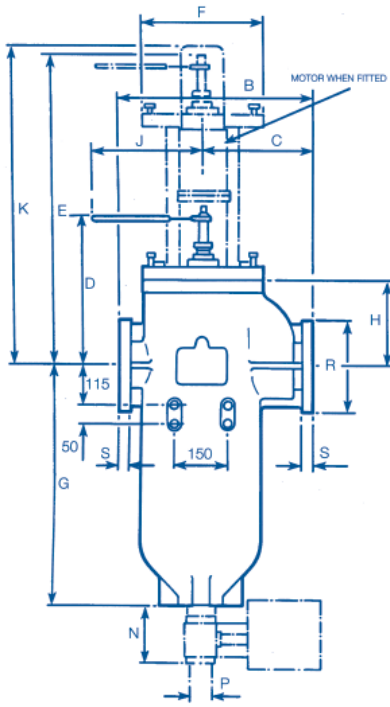

Model 200, 300

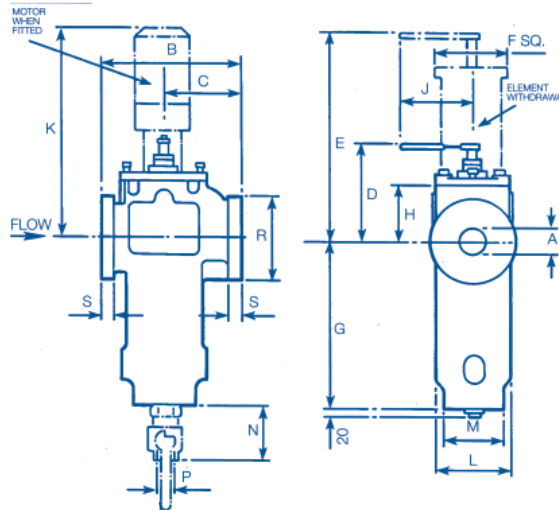

Connections Model 200 only

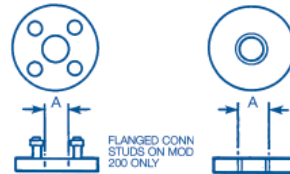

FLOW CONTROL

SPX Flow Control
 Hambridge Road
 Newbury, Berkshire, RG14 5TR
 Phone: +44 (0) 1635 263915 Fax: +44 (0) 1635 36006
 E-mail: airpel@spx.com

Packaging - Processing
Bid on Equipment
 1-847-683-7720
www.bid-on-equipment.com

For more information about our worldwide locations, approvals, certifications, and local representatives, please visit www.spxpe.com.

SPX reserves the right to incorporate our latest design and material changes without notice or obligation. Design features, materials of construction and dimensional data, as described in this bulletin, are provided for your information only and should not be relied upon unless confirmed in writing. Certified drawings are available upon request.