

**Packaging - Processing**  
**Bid on Equipment**

1-847-683-7720  
www.bid-on-equipment.com

**Spee-Dee**  
**Spee-Dee** Packaging Machinery, Inc.  
P.O. Box 656  
Sturtevant, WI 53177  
Cable: SPEE-DEE  
(414) 886-4402

### The "Weight BY Volume Cup"

Spee-Dee is for use with dry weights and will measure and weigh accurately, measure by volume, level the volume with accurate weight and discharge into a container.

### The Heavy Duty CH Series

In addition to free-flowing materials, the Spee-Dee quickly processes heavy, dense, and semi-free flowing products. The 3.5 cubic-foot stainless steel hopper, extra heavy duty locked Geneva indexing drive and the 6" diameter volume cups are standard in the CH Series. The CH-6 can run volumes of 68 to 802 cubic inches or 2-25 pounds (1-10 kilos) for average density products. Adjustable speed fillers operate at a rate of 15 to 30 or more fills per minute. Electric indexing "E" models fill at rates of up to 60 per minute.

### Durable & Reliable

The hopper is constructed of stainless steel, while all other parts are made of light-weight aluminum which can be teflon coated or anodized for corrosion and wear resistance. The heavy Geneva motion drive, gear reducer and variable speed drive motor are enclosed in stainless steel. Our simple design has fewer moving parts for low maintenance.

### Fast, Accurate & Efficient

The heavy duty locked Geneva drive assures quiet, "positive-stop" indexing at each of four cup positions. Cup travel time is minimized while cup time beneath feed hopper and over discharge spout is maximized. This, along with our volume cup leveling system assures you of accurate, quiet filling with uniformity and reliability. Micrometer adjustments fine tune volume to weight.

### Easy to Maintain and Clean

The patented bayonet lock on the main shaft assures easy maintenance. The bottom, plates and cups can be quickly lowered for cleaning and changing the cup without changing volume adjustment.

### Backed with Confidence

Spee-Dee has been manufacturing filling machines for over 40 years. Because of our simple and durable design, Spee-Dee performs — year-after-year. Spee-Dee sets the standard in the cup-filling machines industry.

# CH & CHE Model Fillers

**High-speed, Heavy Duty Filler**  
**Ideal for those "BIG" Filling Jobs**

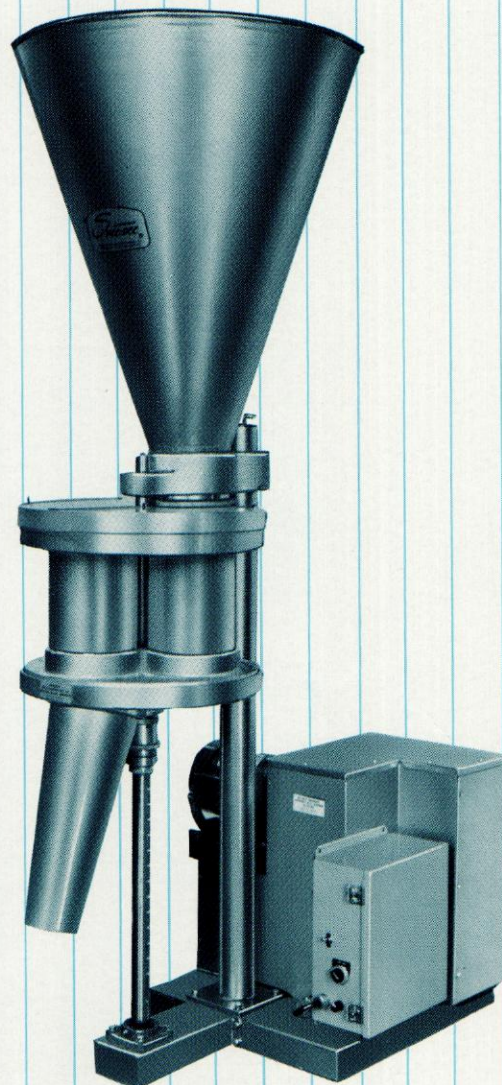

### CH & CHE Model Fillers

**Weight by Measure = Fill with correct Volume.**  
**The same process used by discerning chefs.**  
**Spee-Dee fillers weigh and measure accurately.**  
**The filler then packages with uniform volume.**

**You know that you are getting quality with a Spee-Dee machine. Its engineering design is both simple and durable. You will know about the durability when you experience little down time with Spee-Dee. You will see the engineering when you quickly and easily clean and maintain Spee-Dee.**

**With Spee-Dee you also buy confidence because these have been the industry's standard and leader for over forty years.**

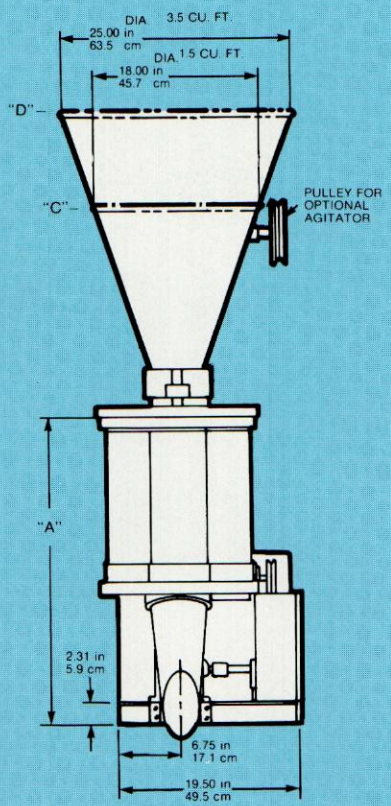
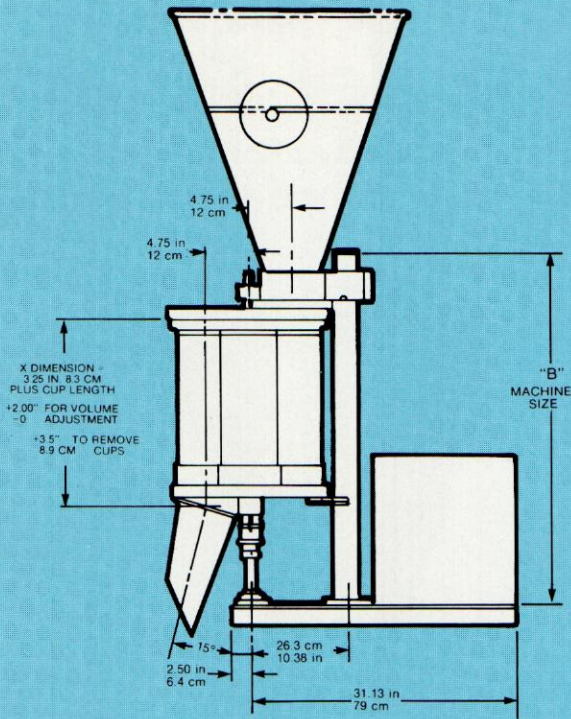

MACH. SIZE	MAX. CUP LGTH.	MAX. VOL.	"A" DIM.	"B" DIM.	"C" DIM.	"D" DIM.
30	8 in. 20.3 cm	283 cu. in. 4.63 liter	24.19 in. 61.4 cm	30 in. 76.2 cm	49 in. 124.4 cm	59 in. 149.8 cm
38	16 in. 40.67 cm	490 cu. in. 8.03 liter	32.19 in. 81.7 cm	38 in. 96.5 cm	57 in. 144.8 cm	67 in. 170.2 cm
44	22 in. 55.9 cm	646 cu. in. 10.6 liter	38.19 in. 97 cm	44 in. 111.7 cm	63 in. 160 cm	73 in. 185.4 cm
50	28 in. 71 cm	802 cu. in. 13.14 liter	44.19 in. 112.2 cm	50 in. 127 cm	69 in. 175.2 cm	79 in. 200.6 cm

**Applications:**

- popcorn/snack food
- rice/beans
- IQF vegetables
- bread crumbs/croutons
- flour
- sugar & confectionaries
- dry pet foods
- wild bird seeds
- wood chips
- potting soil/vermiculite
- fertilizer
- cat litter
- detergent
- dry chemicals
- road salt
- sand & gravel

**Accessories**

- Hopper Agitators
- Electric "On Demand" Indexing
- Foot Switch
- Stainless Steel Plates
- Aluminum Anodizing
- USDA Modifications
- Nylon Wear Rings
- Felt Wear Rings
- S.S. Wear Plate
- Spout Dust Hood
- Explosion Proof Electrical
- Spee-Dee Set Volume Control
- Top Plate Dust Cover
- Special Electrical Corrosion Resistance
- Bag Opener for Light Products
- AND MORE!

**Specifications:**

- Height: See Chart
- Depth: 38"
- Weight: 550#
- Electrical Requirements:
- 115 VAC 60 HZ 6 AMPS Standard.
- 230 VOLT 50 HZ and 3 PH Available.

**SPEE-DEE PACKAGING MACHINERY INC.**

P.O. Box 656  
 Sturtevant, WI 53177  
 414/886-4402 Cable: SPEE-DEE  
 Duns #04-629-5853  
 FAX #414-886-5502