

# SIMPLEX

FILLER COMPANY

## MODEL A-S PISTON FILLER

### MODEL A-S PISTON FILLER MECHANICAL & AIR

Compact and simple in design, the single piston table Model A-S is ideal for filling just about any liquid or viscous product, or any item that is wet and capable of being pumped. With two-speed operation of either 12 or 23 strokes per minute, the Model A-S fills 720 to 1350 containers per hour. Complete adjustment from 10 to 25 strokes per minute is available when the Model A-S is equipped with variable speed drive. Interchangeable cylinders are available with various diameters and are adjustable for filling fractional fluid ounces on up to 32 fluid ounces (1 litre) per stroke.

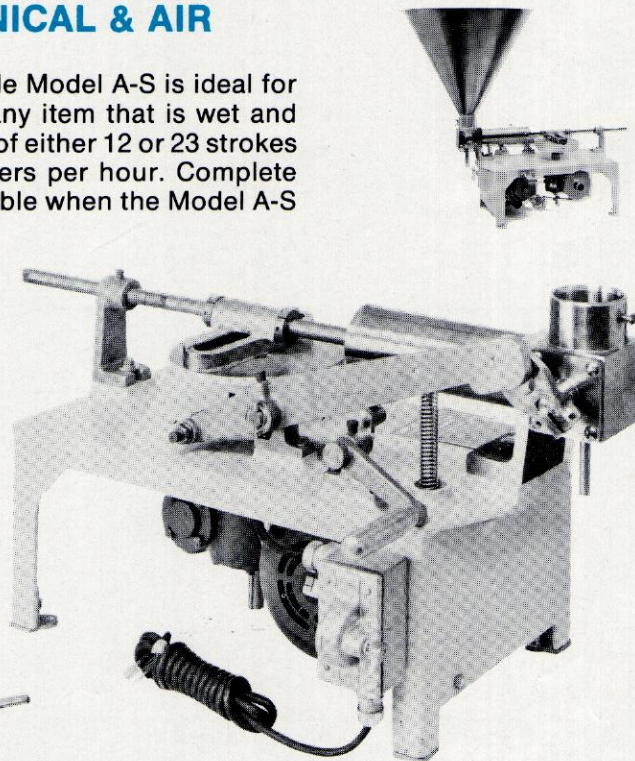
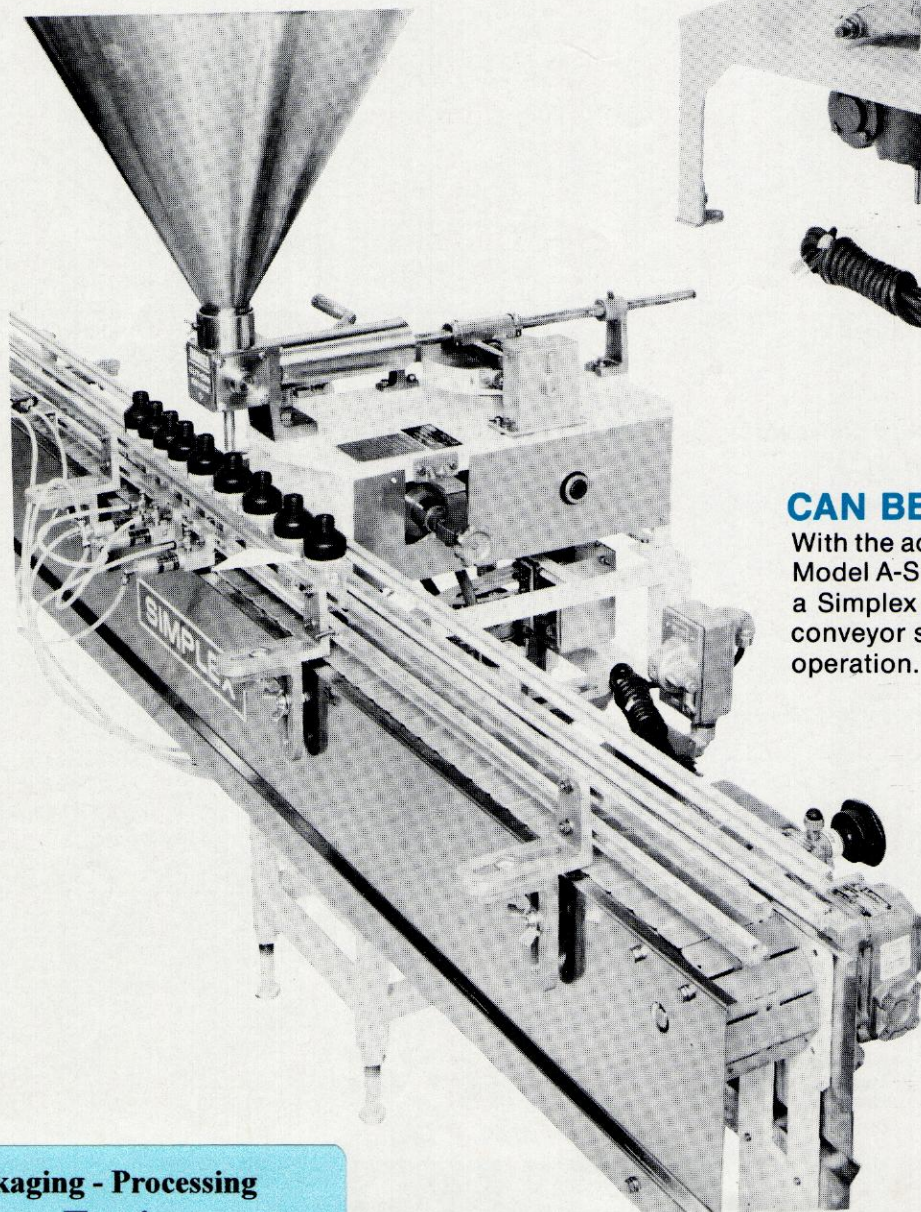

### CAN BE CONVEYORIZED

With the addition of a floor stand, the Model A-S works in conjunction with a Simplex conveyor or with existing conveyor systems for fully automatic operation.

Packaging - Processing  
**Bid on Equipment**

1-847-683-7720

[www.bid-on-equipment.com](http://www.bid-on-equipment.com)

## STANDARD EQUIPMENT (Basic Unit—Single Piston)

316 stainless steel contacts; waterproof switch; 1/3 HP motor (all standard motor voltages available); 6 ft. power cord; 2-speed operation; hand lever shut-off for locking machine in no-fill position; one straight spout

and one cylinder (See cylinder list). Single- or multi-cycle operation through the use of a foot switch is also available.

## ACCESSORIES

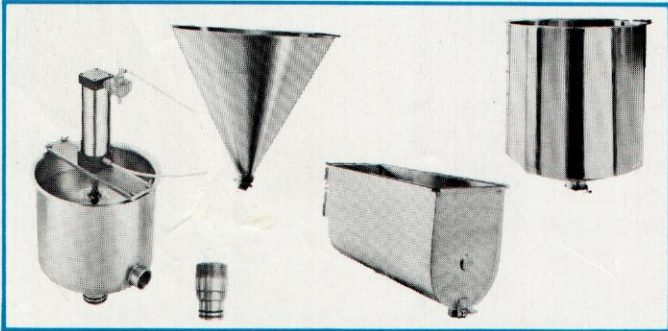

Various hoppers and adaptor for filling from bulk storage available.

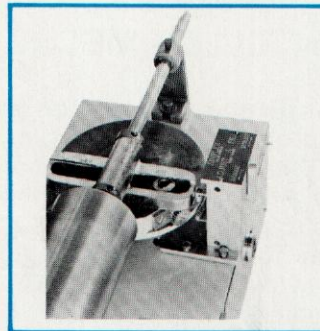

Adjusta-Fill. Allows for increasing or decreasing fill while machine is still in motion.

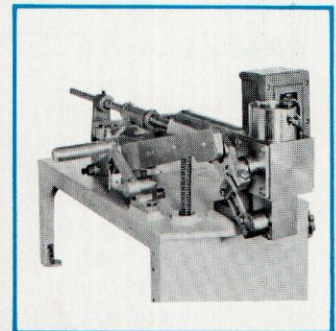

Sanitary swing cut-off valve.

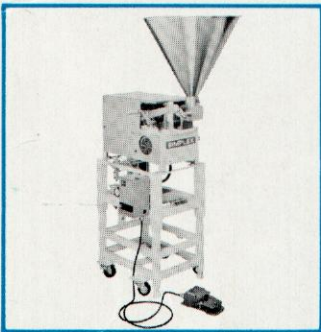

Tubular steel floor stand with 6-inch height adjustment.

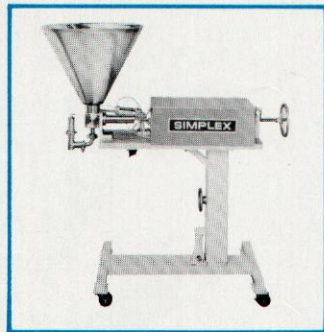

Air-operated version available.

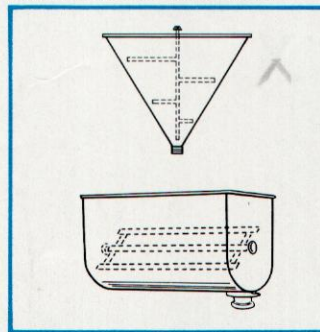

Various agitators available.

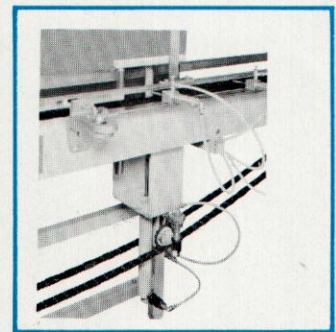

Rising Table. For perfect bottom-up fill.

- Air Indexers—for continuous motion conveyors.
- Vari-Speed Drive—10 to 25 strokes per minute.
- Conveyors as required.
- Interchangeable spouts.

- No container/no fill—to be used with conveyor systems.
- Explosion Proof—Class I, Group D available as required.
- Interchangeable Cylinders—stainless steel, complete with piston and sealing rings.

## SPECIFICATIONS (Basic Model A-S)

Dimensions:	17 1/2" H × 22 1/4" W × 32 1/4" L (44.5 H × 56.5 W × 82 L cm)
Weight:	Net: 200 lbs. (90 kilos) Crated: 275 lbs. (125 kilos)

Cylinder Diameter (Inches)	Maximum Quantities Filled
7/8 in./2.2 cm	1 2/3 Fl. oz./49 ml
1 1/8 in./2.9 cm	2 3/4 Fl. oz./81 ml
1 3/8 in./3.5 cm	4 1/8 Fl. oz./122 ml
1 7/8 in./4.8 cm	8 Fl. oz./236 ml
2 7/8 in./7.3 cm	16 Fl. oz./472 ml
3 7/8 in./9.8 cm	32 Fl. oz./944 ml
4 1/4 in./10.8 cm	45 Fl. oz./1328 ml

THE FINEST NAME IN PISTON AND PRESSURE FILLERS

**SIMPLEX**  
FILLER COMPANY

3450 ARDEN ROAD, HAYWARD, CALIFORNIA 94545  
TELEPHONE: (415) 785-8010

Packaging - Processing  
**Bid on Equipment**

1-847-683-7720

www.bid-on-equipment.com