

Rotary Ring Series Stretch Wrappers

OCTOPUS™

303 BP Automatic



- Wraps up to 45 loads per hour
- Patented "tail tuck" film tail containment
- Programmable roping device
- Proven design for the block and paver industry
- Installs over existing conveyor or can be provided with conveyor
- Allen-Bradley PLC control
- Octo-Thread carriage allows easy film threading
- Optional "Logo Wrap"

Octopus 303 BP

Automatic Rotary Ring Stretch Wrapper

Specifications

Standard configuration listed below. Please contact your sales representative for other available configurations.

Performance

Loads per hour	Up to 45
Maximum load size	48" W x 50" L x 80" H (69" dia.)
Minimum load size	36" W x 36" L x 28" H (film clamp justified)
Maximum load weight	Dependent on conveyor

Film Delivery System

Film capacity	20" roll width x 10" dia.
Film payout	Strain gauge
Pre-stretch level	250% (optional 75% to 300%)
Force control	Variable
Film threading	Octo-Thread design; W film threading pattern
Film tail treatment	"Tail tucker" with programmable roping

Controls

Controller	Allen-Bradley PLC
Operator interface	Touch screen
Load height sensor	Photo eye
Wrap settings	Re-wrap function, overwrap and overlap adjustments
Wrap counters	Independent top and bottom
Emergency stop	Mushroom head
Electrical disconnect	Lockable
Electrical enclosure	CSA approved

Power Requirements

Voltage	480 VAC, 3 phase, 30 amps
Pneumatic	80 psi, 3 CFM (clean, dry air)

Ring Lift and Rotation

Lift method	Reinforced belt
Lift motor	480 VAC - SEW Eurodrive
Lift control	Variable frequency drive
Rotation method	Belt drive
Rotation motor	480 VAC - SEW Eurodrive
Rotation control	Variable frequency drive

Structure

Machine weight	3,500 pounds
Construction	Aluminum frame and structural steel channel
Color	Structure: Light and dark bronze Ring frame: Yellow

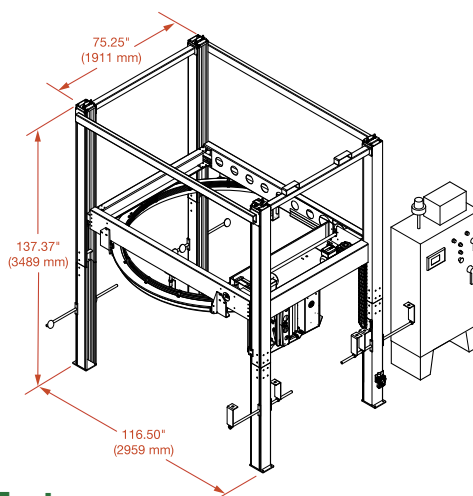

Additional Features

- 7' high mesh fence around system
- Entry gate with automatic shutdown
- Upper and lower ring shutdown switches
- Internal wrap zone location photo eyes
- Infeed and outfeed shutdown photo eyes
- Infeed and exit conveyor sequence interlocks:
 - Customer ready to send load
 - Customer ready to receive load
 - Machine ready to send load
 - Machine ready to receive load

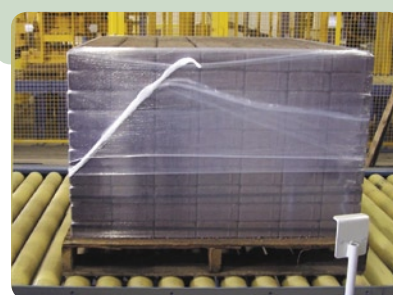

Tail tucker

The patented tail tucker device "tucks" the film tail under the last two full webs of stretch film, eliminating the "loose tails" commonly encountered in outdoor storage and open truck transportation.



Optional Logo Wrap

Logo wrap applies printed film with your company name and logo under the standard stretch film.



Signode Packaging Systems
 3610 West Lake Avenue
 Glenview, Illinois 60026
 1-800-323-2464
 www.signode.com