

SIGNODE **LBX-Magazine**™

The new standard for magazine bundling

***Precise
bundle control***

***Unmatched
simplicity***

***Maximum
productivity***

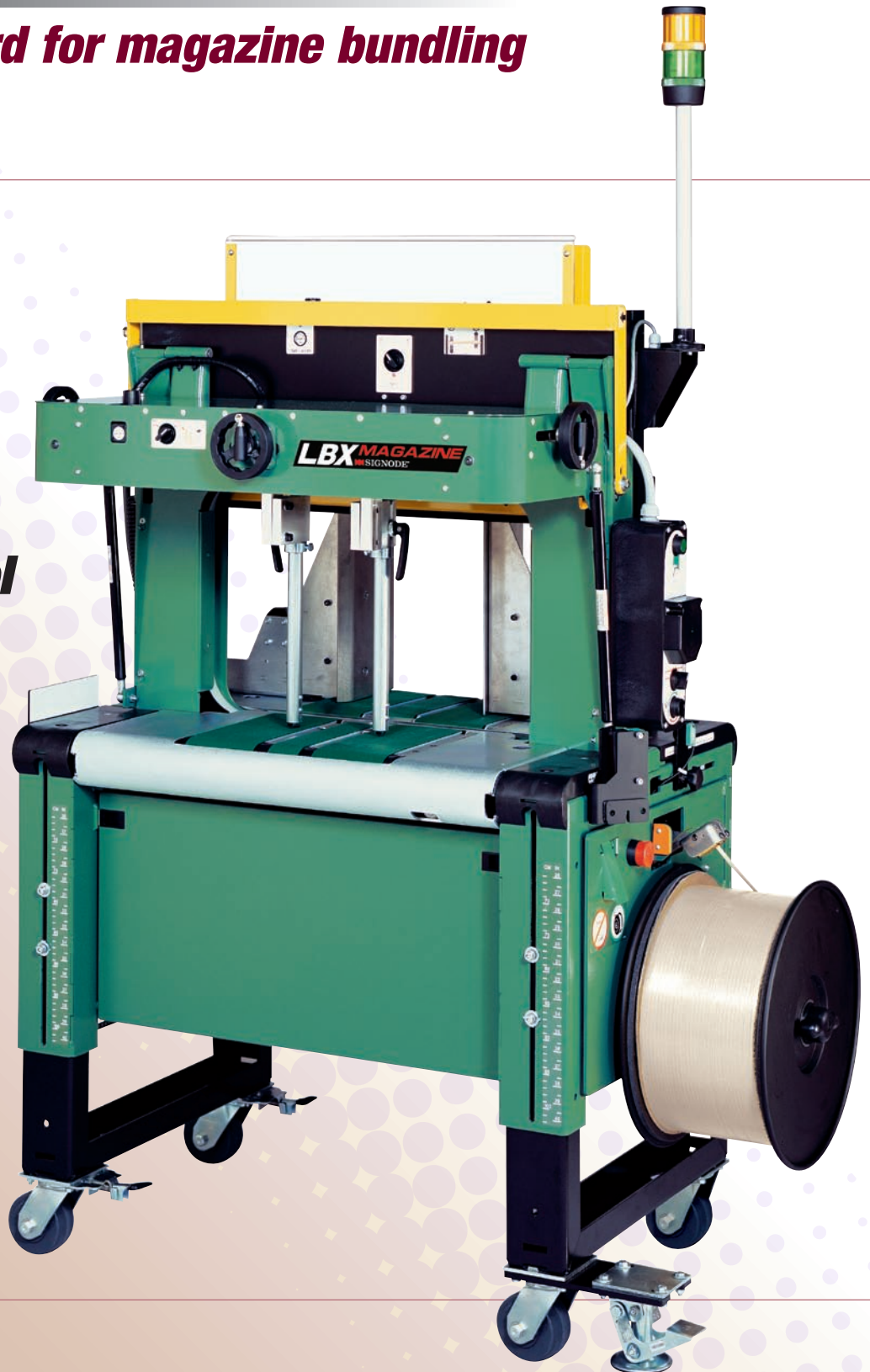

The new standard for magazine bundling



Ensures superior bundle control

Three-belt tabletop

A three-belt tabletop design provides precise bundle handling for a wide range of loads, from small, 5" wide zip sorted bundles to larger magazine formats.



Pop-up bundle diverter

A proprietary pop-up bundle diverter lifts small stacks into the bundle stops, preventing damage from "shingling" and eliminating the need for precise adjustment of the bundle stops.

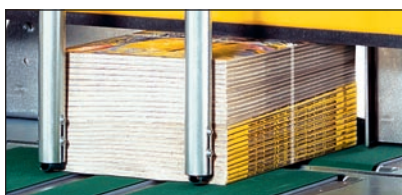

Ultra low strap tension

The LBX-Magazine is the only machine on the market that allows adjustable strap tension to as low as 2 lbs preventing indentations on book edges.

Maximizes productivity



Quick make-ready time

Can be adjusted for a new run in seconds without the use of tools. Unique, independent bundle adjustments can be set and fine-tuned during production runs.

Automatic cut-off and refeed option

Signode's patented automatic cut-off and refeed feature automatically ejects misfed strap, rethreads itself and continues strapping without operator intervention.

Strap feeds from either direction

Strap coil pays off from either direction, eliminating the downtime and material waste resulting from incorrect coil loading.

Simplifies maintenance and troubleshooting

Easy maintenance

Bundle handling device hinges out of the way, enabling quick, easy access to the tabletop and the strapping head without the use of tools. With no drive belts, clutches or pulleys in the strapping head, all routine maintenance can be performed by the operator.

Fully accessible strap path

Lifting a single handle provides full access to the strap path. No screws, parts, springs or wing nuts need to be removed.

LBX-Magazine Specifications

Bundle size:

Minimum: 5" W x 7" L (125 mm x 180 mm)

Maximum: 18" W x 18" L (455 mm x 455 mm)

Height: Up to 14-1/2" (370 mm)

Cycle rate: Up to 42 straps per minute. Actual production will vary depending on bundle size.

Chute size: 20" W x 15" H (510 mm x 380 mm)

Conveyor speed: 50-150 ft. per minute (15 m - 45 m)

Strapping: 5 mm or 6 mm polypropylene strapping

Compression: Up to 120 lbs at 90 psi

Conveyor height: Adjustable from 26" to 39" (660 mm to 990 mm)

Optional height kit: 40" to 54" (1015 mm to 1370 mm)

Electrical: 230 volt, 60Hz, FLA 4.7 amp; 460 volt, 60Hz, FLA 2.3 amp

Shipping weight: 950 lbs (430 kg)

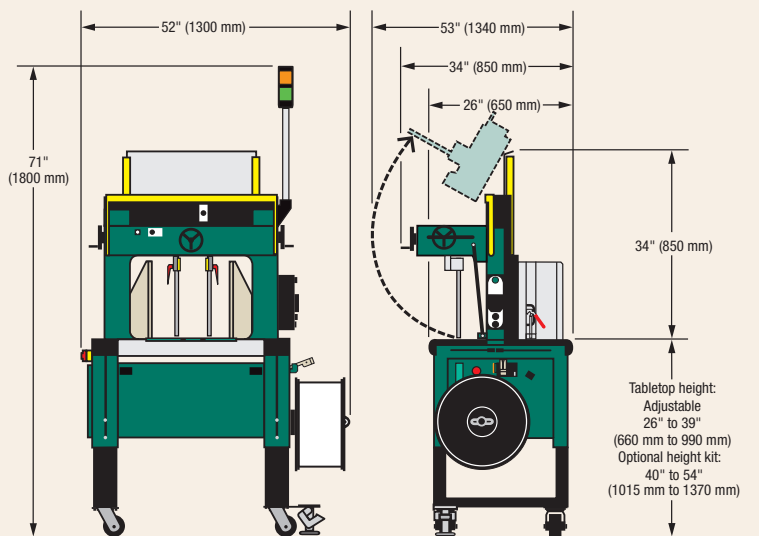

SIGNODE®

3610 West Lake Avenue
Glenview, Illinois 60026
1-800-323-2464
www.signode.com