

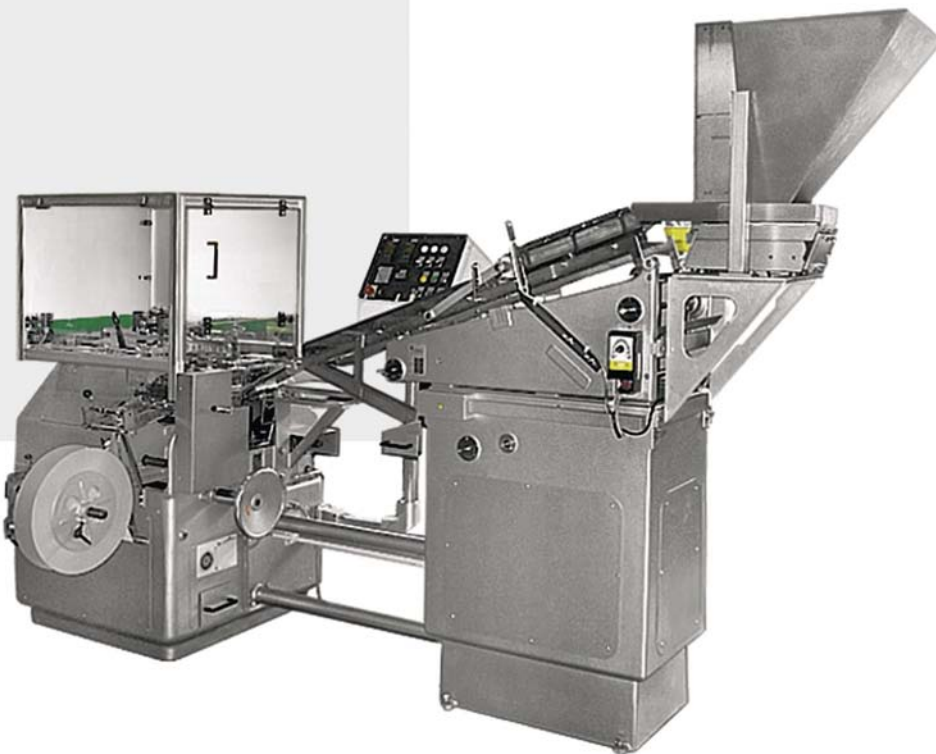

## Wrapping machines EZ 31 and EZ 2

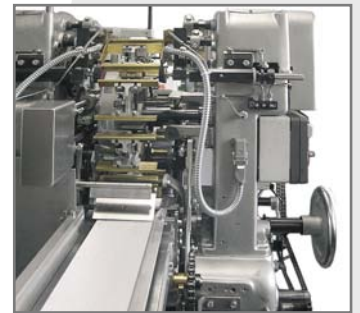

Wrapping machine

## EZ 31 Pack-Master

To pack square or rectangular products like for example chewing gum-chiclets, erasers and tablets

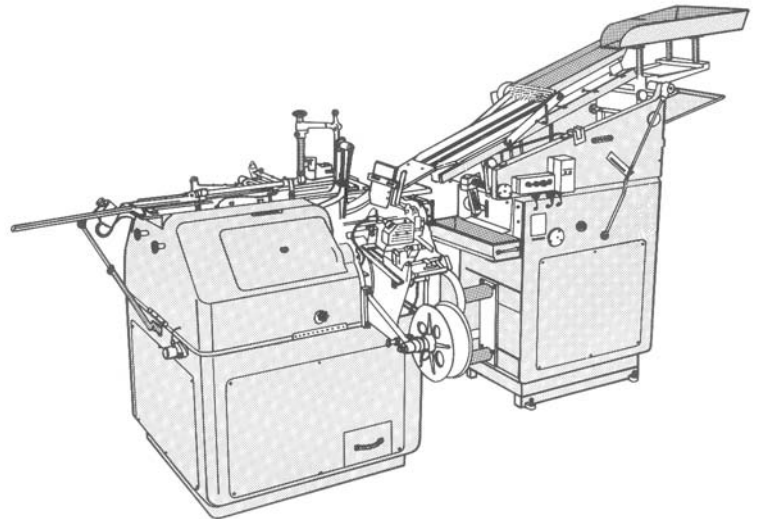

### Technical data

**Range:**

Length from 16 to 120 mm  
Width from 12 to 40 mm  
Height from 6 to 20 mm

**Machine dimensions:**

Machine/Alimentation  
Length 190 cm/190 cm  
Width 140 cm/100 cm  
Height 150 cm/160 cm

**Netto weight/Gross weight:**

1000 kg/1480 kg

**Voltage:**

Three-phase 220/400 V a.c.,  
50 cycles; Special voltage against  
extra charge.

**Consumption:**

1,5 KVA

**Appr. Output:**

60 to 100 packs /min.  
In special design up to  
150 packs/min.

**Packaging material:**

Lined aluminium, paper, wax  
paper, cellophane and the like  
is glued, heatsealed or only  
folded from the foil reel.

Additional wrapping with glued  
paper-banderoles taken from a  
stack is possible (as special design  
and also from the roll).

**Feeding:**

with longitudinal vibrating system  
round vibrator



## Wrapping machine

### EZ 2

To pack round products like for example tablets, sweets and charcoal briquets

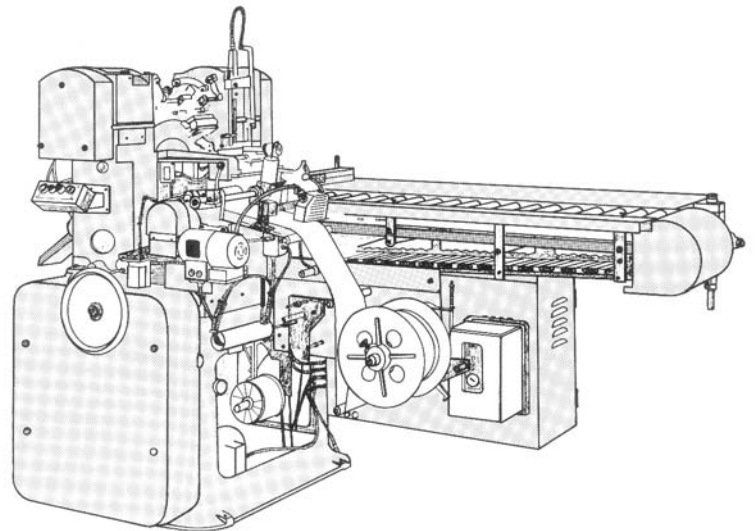

## Technical data

**Range:**

Diameter of 16 to 40 mm  
Length from 25 to 130 mm  
As a special execution up to a diameter of 50 mm

**Case dimension:**

180 x 130 x 130 cm

**Netto weight/Gross weight:**

700 kg/1000 kg

**Voltage:**

Three-phase 220/400 V a.c.,  
50 cycles; special voltage  
against extra charge

**Consumption:**

2.1 KVA

**Approximate output:**

60 to 100 packs /min.  
In special design up to  
120 packs/min.

**Packaging material:**

Lined aluminium, paper, wax  
paper, cellophane and the like  
is glued, heatsealed or only  
folded from the foil reel.  
Additional wrapping with glued  
paper-banderoles taken from a  
stack is possible (as special design  
and also from the roll).

**Feeding:**

with longitudinal vibrating system