

INFORMATION

SHICK TUBE-VEYOR CORPORATION'S full line of High-Vacuum (HV) Dust Collectors are designed to effectively separate pneumatically conveyed products from a vacuum air stream. Dust infused air enters the unit and passes through a filter bag housing to the clean air plenum and then the clean air is expelled near the top of the unit. An electric timer sequentially activates valves which direct a concise burst of compressed air into the bags causing accumulated dust to be released from the bags and fall into the vessel. In addition to reducing facility maintenance requirements, Shick's HV Dust Collector will help companies meet air quality regulation and employee safety requirements. These HV units are available in a wide range of bag lengths and filtering materials depending on the conveyed material characteristics. HV units can be mounted on a variety of storage vessels and the cylindrical, reinforced design is suitable for vacuum conveying applications up to 17" Hg.

FEATURES

CLEAN AIR PLENUM - Includes mounting flange at tube sheet, lifting lugs, compressed air header with 1" pipe coupling for pressure gauge, 1" pipe coupling for plant air and 1/4" pipe coupling for drain, and diaphragm valves.

TIMER BOX - Includes pre-wired timer board with adjustable timer for 120 VAC, single phase, 60 hertz and includes solenoid valves. (Other voltages available upon request.)

BAG HOUSING - Equipped with mating flange at top and bottom, safety grate, and access door.

NEMA - 4 and 9 standard, 4X and 7 available.

MATERIAL OF CONSTRUCTION - 12 GA, ASTM 569 carbon steel or ASTM A240 304 stainless steel sheet metal (in material contact or all stainless options).

GAUGES - Supplied with a 0-200 p.s.i.g. gauge and pressure differential gauge (standard).

CARBON FINISHES - Internal welds are ground to a 36 grit finish on weld seams only. Internal finish is clear phenolic or epoxy. External paint is primed with white enamel finish coat.

STAINLESS STEEL FINISHES - Interior welds ground to a 80 grit finish with no cracks, pits or crevices, hard wheel finish on weld seams only. Exterior welds to be cleaned. Sheet is a 2B mill finish.



HV DUST COLLECTORS

Packaging - Processing
Bid on Equipment
1-847-854-8577
www.bid-on-equipment.com

SHICK TUBE-VEYOR CORPORATION

4346 Clary Boulevard • Kansas City, Missouri 64130 • P (816) 861-7224 • F (816) 921-1901

SCHEMATICS

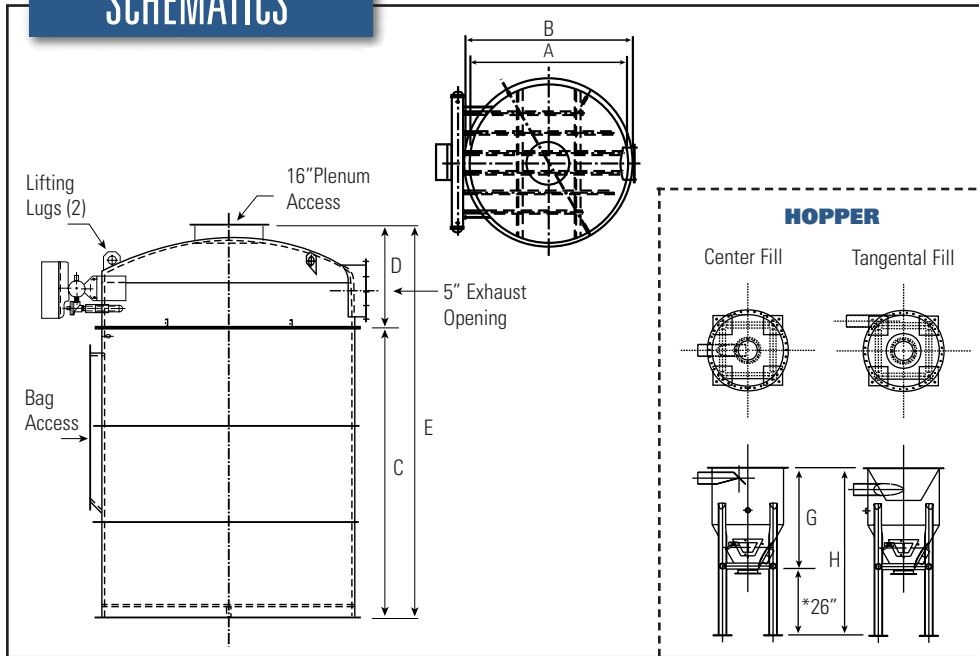

ATTACHMENTS

Consider the following attachments:

1. Hopper with legs.
2. Stub transition.
3. Fan with bracket.
4. Pressure differential switch.

NOTES:

1. Dimension includes tubesheet thickness.
2. NEMA 9 units are shipped with polyester bags with stainless steel ground wire and metal bag cups.
3. Bags, cages and clamps shipped separately for field installation.
4. Hopper is 60°.
5. HV-24 Units and above are provided with double bag housing access doors.

OPTIONS FOR

BAGS:

- 16 oz. polyester (standard)
- 16 oz. polyester with ground wire
- 22 oz. polyester
- BHA Tex™ PTFE membrane

FINISH:

Stainless: 4B finish sheet with interior welds ground to a 150 grit finish.

DIMENSIONS - HOPPER

Model No.	G inch/ mm	H inch/ mm
HV-8	44.625/1133	70.625/1794
HV-14	49.5/1257	75.5/1918
HV-18	54.75/1391	80.75/2051
HV-24	60.25/1530	86.25/2191
HV-30	65.5/1664	91.5/2324
HV-38	70.75/1797	96.75/2457
HV-46	76/1930	102/2591
HV-54	81.25/2064	107.25/2724
HV-64	86.5/2197	112.5/2858
HV-74	91.75/2330	117.75/2991

* 26" height is based on 8" discharge and will vary with the size of the discharge.

DIMENSIONS - UNIT

Model No.	Cloth Area Sq. Ft.	No. of bags	Comp. Air (SCFM)	A inch/mm	B inch/mm	C inch/mm	D inch/mm	E inch/mm	Wt** Lb./Kg.
18HV-8	18	8	4	30/762	34/1864	29/737	20.75/527	49.75/1264	200/91
36HV-8	36	8	4.1	30/762	34/1864	47/1194	20.75/527	67.75/1721	215/98
58HV-8	58	8	4.5	30/762	34/1864	69/1753	20.75/527	89.75/2280	220/100
84HV-8	84	8	5.0	30/762	34/1864	96/2438	20.75/527	116.75/2965	230/104
36HV-14	63	14	4.0	36/914	40/1016	47/1194	21.50/546	68.50/1740	275/125
58HV-14	102	14	5.5	36/914	40/1016	69/1753	21.50/546	90.50/2299	320/145
84HV-14	147	14	5.8	36/914	40/1016	96/2438	21.50/546	117.50/2985	370/168
36HV-18	81	18	5.5	42/1067	46/1168	47/1194	22.19/564	69.19/1757	300/136
58HV-18	131	18	6.0	42/1067	46/1168	69/1753	22.19/564	84.19/2138	375/170
84HV-18	190	18	6.5	42/1067	46/1168	96/2438	22.19/564	118.19/3002	425/193
58HV-24	175	24	6.7	48/1219	52/1321	69/1753	22.75/578	91.75/2330	475/215
84HV-24	253	24	7.0	48/1219	52/1321	96/2438	22.75/578	118.75/3016	530/240
58HV-30	218	30	7.5	54/1372	58/1473	69/1753	23.75/603	92.75/2356	500/227
84HV-30	316	30	7.8	54/1372	58/1473	96/2438	23.75/603	119.75/3042	675/306
58HV-38	276	38	8.0	60/1524	64/1626	69/1753	24.50/622	93.50/2375	680/308
84HV-38	400	38	8.5	60/1524	64/1626	96/2438	24.50/622	120.50/3061	750/340
58HV-46	335	46	9.0	66/1676	70/1778	69/1753	25.50/648	94.50/2400	800/363
84HV-46	484	46	9.5	66/1676	70/1778	96/2438	25.50/648	121.50/3086	910/413
58HV-54	393	54	10.5	72/1829	76/1930	69/1753	26.25/668	95.25/2419	950/431
84HV-54	569	54	11.0	72/1829	76/1930	96/2438	26.25/668	122.25/3105	1100/499
58HV-64	466	64	11.0	78/1981	82/2083	69/1753	27/686	96/2438	1275/578
84HV-64	674	64	11.5	78/1981	82/2083	96/2438	27/686	123/3124	1410/640
58HV-74	538	74	12.5	84/2134	88/2235	69/1753	27.88/708	96.86/2460	1475/669
84HV-74	780	74	13.5	84/2134	88/2235	96/2438	27.88/708	123.86/3146	1650/748

** All weights are for carbon steel units and are nominal.

WORLD HEADQUARTERS:

Shick Tube-Veyor Corporation
4346 Clary Boulevard, Kansas City, MO 64130 USA
Tel: (816) 861-7224 Fax: (816) 921-1901

ASIA PACIFIC:

Shick Tube-Veyor Asia Pacific Pte Ltd
Blk 5000 Ang Mo Kio Ave 5 #05-07
Techplace II, Singapore 569870
Tel: (65) 4824600 Fax: (65) 4818255

Information on this page is subject to change without notice. For additional information on this and other Shick Tube-Veyor products and services, please call Shick directly or your local representative.

REPRESENTED BY:

Packaging - Processing
Bid on Equipment
1-847-854-8577
www.bid-on-equipment.com



SHICK TUBE-VEYOR CORPORATION

HVA K96 10K