

# SELLERS

Packaging - Processing  
**Bid on Equipment**  
1-847-683-7720  
[www.bid-on-equipment.com](http://www.bid-on-equipment.com)

## HEAT-N-STORE STORAGE TYPE WATER HEATER HEATING MEDIUM – STEAM

### GENERAL DESCRIPTION

The Sellers Heat-N-Store is an automatic, completely packaged storage type large volume water heater. The water is heated with a heat exchanger using steam as the heating medium. The heater has two sections incorporated into one assembly – a recovery section and a storage section.

### RECOVERY SECTION

The recovery section consists of a shell and tube type heat exchanger into which steam is admitted at a controlled rate by a flow control valve. The water being heated is continuously pumped at a fixed rate through the shell of the heat exchanger. By a series of baffles, turbulent scrubbing of the tube surfaces more than doubles the rate of heat transfer.

### STORAGE SECTION

The storage section is an ASME Code Section VIII built cylindrical tank with convex heads. It is provided with a 12" x 16" manhole. Epoxy Phenolic lining and insulated with 2" steel jacketed fiberglass are standard. Storage section capacities and dimensions of all models are found on the inside pages.

The completed Heat-N-Store is factory tested and mounted on a skid type base. The package of controls and accessories listed in this specification sheet is factory piped and installed. All controls are tested after installation to insure proper functioning. The heater arrives ready for installation and operation.

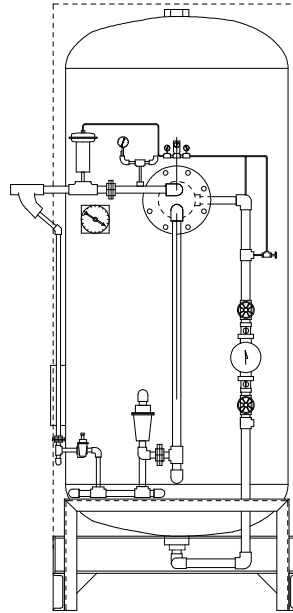

Sellers Vertical Steam-to-Water  
Heat-N-Store Water Heater

### SELECTING THE MODEL NUMBER

The Heat-N-Store makes the specifying, purchase and installation of a storage water heating system a simple procedure.

To select a model, determine by any preferred sizing method the hourly recovery rate and the storage volume which best meet the job requirements. Among factors affecting the ratio between the capacities of the two sections of the Heat-N-Store are the rate and duration of peak periods of hot water use and the length of recovery periods.

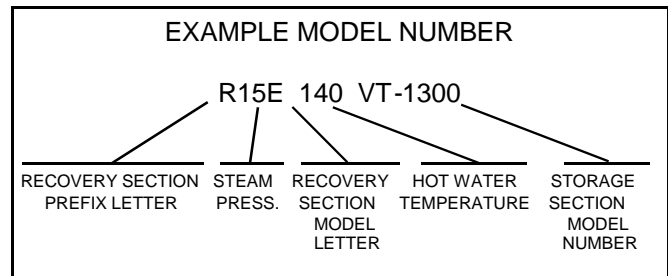

SELLERS ENGINEERING CO., MANUFACTURING BOILERS AND WATER HEATERS SINCE 1931.



# WATER HEATER RECOVERY CAPACITIES

RECOVERY MODEL LETTER	A	B	C	D	E	F	G	H	I	J	K
<b>STEAM PRESSURE</b>	<b>40 TO 140 DEGREES F. (GALLONS PER HOUR)</b>										
2	740	1000	1370	1820	2140	2800	4160	5250	6240	7200	9230
5	780	1000	1380	1890	2310	2970	4140	5590	6620	7600	9750
10	740	1130	1420	1970	2420	3010	4460	5590	6240	8500	10500
15	840	1230	1580	2180	2640	3350	4750	5800	7070	7590	11540
25	990	1200	1840	2260	2860	3900	5560	6860	8270	9060	13140
50	1150	1540	2080	2790	3000	4590	5720	7800	8470	11410	14400
75	1220	1670	2260	3050	3690	5250	7090	9200	10600	13180	16120
100	1400	1890	2570	3470	4130	5050	7980	9350	11990	13390	18160
<b>STEAM PRESSURE</b>	<b>40 TO 180 DEGREES F. (GALLONS PER HOUR)</b>										
2	390	530	690	940	1120	1480	2220	2780	3300	3780	4850
5	420	560	710	990	1210	1640	2240	2810	3180	4260	5270
10	450	630	850	1020	1310	1800	2530	3120	3790	4170	6130
15	510	620	890	1170	1480	1800	2600	3370	3980	4870	5370
25	560	760	1160	1300	1590	2220	3200	3640	4650	5380	6720
50	640	890	1190	1620	1990	2910	3810	5050	5640	7260	8650
75	800	1090	1390	1710	2210	2900	4580	5360	6890	7680	10430
100	910	1100	1530	2040	2560	3390	5170	6220	6880	8830	10140

\*NOTES: RECOVERY CAPACITIES APPLY TO SINGLE WALL UNITS ONLY.  
CONSULT FACTORY FOR DOUBLE WALL CAPACITIES.

## STANDARD EQUIPMENT FURNISHED

**Pressure Vessel:** ASME stamped.

**Manhole:** 12" x 16"

**Handholes:** 3-1/2" x 4-1/2"

**Base:** Heavy duty structural steel skid

**Insulation:** 2" fiberglass with double painted steel jacket

**Epoxy Lining:** Epoxy phenolic lining applied to sand blasted surface and baked at high temperature

**Heat Exchanger with copper tubes.** Consult the factory for optional tubing material

**Steam flow control valve**

**Heat exchanger circulating pump**

**Pump isolation valves**

**Pump loading valve**

**Main and auxiliary steam traps.**

**Thermal Sensor**

**Lifting lug(s)**

**Pressure Gauge:** 4-1/2" dial type mounted on pigtail

**Temperature Gauge:** 5" dial type

**Temperature and Pressure Relief Valve**

**Magnesium Anodes:** Two (2) 1-5/16" x82 or longer

**Copper water line piping**

**Cold water distribution baffle**

**Ten year warranty on pressure vessel**

**Finished with heavy jade green machinery enamel**

**Initial start-up and operator's instruction provided**

by a company representative

# VERTICAL HEAT-N-STORE PACKAGED WATER HEATER

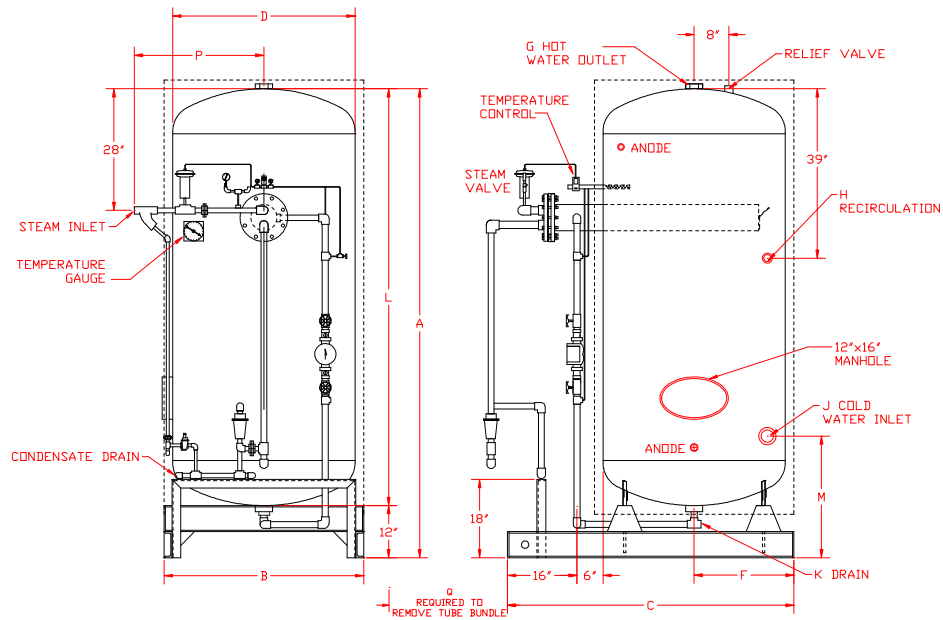

## DIMENSIONS

CAPACITY (GALLONS)	MODEL NUMBER	D	L	A	B	C	F	G	H	J	K
170	VT-170	30	60	72	34	54	17	1 1/2	1	1 1/2	1 1/2
200	VT-200	30	72	84	34	54	17	1 1/2	1	1 1/2	1 1/2
240	VT-240	30	84	96	34	54	17	1 1/2	1	1 1/2	1 1/2
280	VT-280	36	72	84	40	60	20	1 1/2	1	1 1/2	1 1/2
335	VT-335	36	84	96	40	60	20	2	1	2	1 1/2
390	VT-390	36	96	108	40	60	20	2	1	2	1 1/2
460	VT-460	42	84	96	46	66	23	2	1 1/2	2	1 1/2
530	VT-530	42	96	108	46	66	23	2 1/2	1 1/2	2 1/2	1 1/2
600	VT-600	42	108	120	46	66	23	2 1/2	1 1/2	2 1/2	1 1/2
680	VT-680	48	96	108	52	72	26	2 1/2	1 1/2	2 1/2	1 1/2
770	VT-770	8	108	120	52	72	26	3	1 1/2	3	1 1/2
865	VT-865	48	120	132	52	72	26	3	1 1/2	3	1 1/2
1300	VT-1300	60	120	132	64	84	32	3	1 1/2	3	2
1980	VT-1980	72	120	132	72	96	38	3	1 1/2	3	2

\*\*\* All Dimensions In Inches \*\*\*

## RECOVERY SECTION DIMENSIONS

RECOVERY MODEL LETTER		A	B	C	D	E	F	G	H	I	J	K
MINIMUM TANK DIAMETER*		30	42	30	42	30	42	42	60	72	84	84
WATER VALVE LOCATION	P	22	28	27	27	33	33	41	45	45	45	55
EXCHANGER REMOVAL	Q	32	44	34	46	35	47	51	63	75	87	87
RELIEF VALVE-IPS	R	1.5	1.5	1.5	1.5	1.5	1.5	2	2	2-2	2-2	2-2

\*NOTE: Small diameter vertical tanks may be used if abnormal overhang is acceptable.

# HORIZONTAL HEAT-N-STORE PACKAGED WATER HEATER

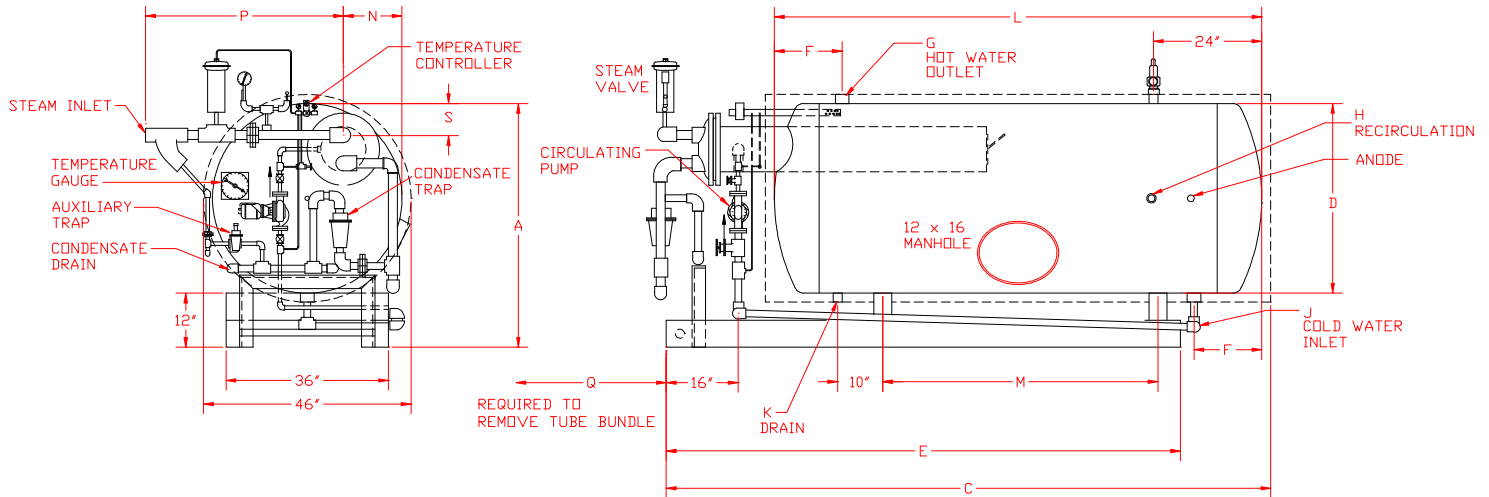

## DIMENSIONS

CAPACITY (GALLONS)	MODEL NUMBER	D	L	A	B	C	E	F	G	H	J	K	M	N	S
170	HT-170	30	60	42	24	84	70	12	1 1/2	1	1 1/2	1 1/2	20	11	8
200	HT-200	30	72	42	24	96	82	12	1 1/2	1	1 1/2	1 1/2	32	11	8
240	HT-240	30	84	42	24	108	94	12	1 1/2	1	1 1/2	1 1/2	44	11	8
280	HT-280	36	72	48	30	96	81	13	1 1/2	1	1 1/2	1 1/2	30	12	9
335	HT-335	36	84	48	30	108	93	13	2	1	2	1 1/2	42	12	9
390	HT-390	36	96	48	30	120	105	13	2	1	2	1 1/2	54	12	9
460	HT-460	42	84	54	36	108	90	15	2	1 1/2	2	1 1/2	37	13	10
530	HT-530	42	96	54	36	120	102	15	2 1/2	1 1/2	2 1/2	1 1/2	49	13	10
600	HT-600	42	108	54	36	132	114	15	2 1/2	1 1/2	2 1/2	1 1/2	61	13	10
680	HT-680	48	96	60	42	120	100	17	2 1/2	1 1/2	2 1/2	1 1/2	45	14	11
770	HT-770	48	108	60	42	132	112	17	2 1/2	1 1/2	2 1/2	1 1/2	57	14	11
865	HT-865	48	120	60	42	144	124	17	3	1 1/2	3	1 1/2	69	14	11
1050	HT-1050	48	144	60	42	168	148	17	3	1 1/2	3	1 1/2	93	14	11
1235	HT-1235	48	168	60	42	192	172	17	3	1 1/2	3	1 1/2	117	14	11
1000	HT-1000	60	96	72	54	120	96	19	3	1 1/2	3	2	39	16	12
1300	HT-1300	60	120	72	54	144	120	19	3	1 1/2	3	2	63	16	12
1600	HT-1600	60	144	72	54	168	144	19	3	1 1/2	3	2	87	16	12
1900	HT-1900	60	168	72	54	192	168	19	3	1 1/2	3	2	111	16	12
1980	HT-1980	72	120	84	66	144	115	23	3	1 1/2	3	2	54	18	14
2400	HT-2400	72	144	84	66	168	139	23	3	1 1/2	3	2	78	18	14
2700	HT-2700	72	168	84	66	192	163	23	3	1 1/2	3	2	102	18	14
3050	HT-3050	84	144	96	78	168	139	23	3	1 1/2	3	2	78	20	16
4000	HT-4000	96	144	108	90	168	138	24	3	1 1/2	3	2	76	21	18

\*\*\* All Dimensions In Inches \*\*\*



P.O. Box 48 · Danville, Kentucky 40423-0048

Phone: 859/236-3181

Web-site: [sellersengineering.com](http://sellersengineering.com)

Packaging - Processing

**Bid on Equipment**

1-847-683-7720

[www.bid-on-equipment.com](http://www.bid-on-equipment.com)