

fully automated tray-sealing unit SEALPAC A5 SEALPAC A5 fully automated tray-sealing unit

SEALPAC® A5

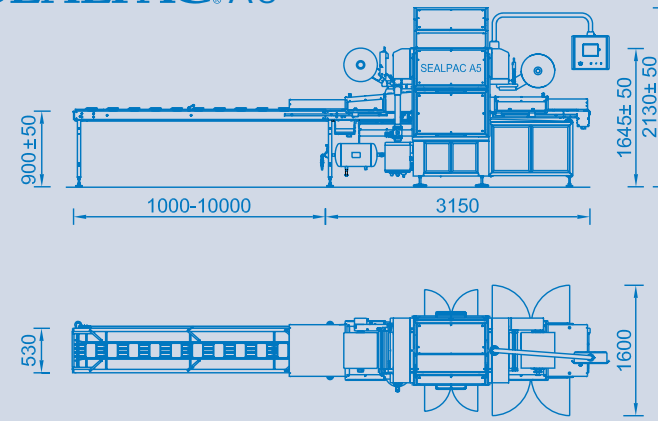

measures in mm

TECHNICAL INFORMATION

Output:	up to 70 trays/minute ¹⁾
Capacity:	up to maximum 15 cycles/minute ²⁾
Machine weight:	1,600 kg
Air pressure:	min. 6 bar
Connection values:	3 x 400/230V+N+E - max. 8 kW ³⁾

- ¹⁾ Machine outputs quoted refer to packaging mode vacuum/gas for food. Outputs are generally higher for sealing applications only.
²⁾ Capacity may vary according to tray format and other process data.
³⁾ Connection values vary according to equipment and operation specification.
 BG/GS safety tested and certified. All rights reserved for technical modifications.

For excellent service wherever you are.
Your SEALPAC partner:

SEALPAC – your package to success.

As a high-precision manufacturer, we support our customers in reaching their targets. We work together to create cost-effective and guaranteed high-quality solutions. Our flexible and dedicated approach will guide you in exploring individual alternatives to help shape your future.

SEALPAC International bv | Drielandendreef 40a | NL-3845 CA Harderwijk
 Telefon: +31 (0) 341 46 20 30 | international@sealpacglobe.de | www.sealpac.eu

SEALPAC®
Forming Innovations

THE COMPACT CLASS

SEALPAC® A5

FULLY AUTOMATED TRAY-SEALING UNIT



All-in-one complete.
 Saves space and costs.

SEALPAC®
Forming Innovations

THE COMPACT CLASS

SEALPAC® A5

FULLY AUTOMATED TRAY-SEALING UNIT

The **SEALPAC A5** stands for robust flexibility and high-level adaptability to individual applications.

SEALPAC-packaging systems operate successfully worldwide. As a high-precision manufacturer, we share our expertise with your production. Our full product range is based on the quality standard "Made in Germany". Our support is customised to meet all your needs for a specific tray-sealing system. Our solutions are tailored to your production and profitability – that means for example lower maintenance costs.

In brief: state-of-art technology from an experienced manufacturer.

SEALPAC A5 has so much to offer: compact design and total performance. We bring you the professional approach crucial in industrial processing.

Fully automated, this newly designed unit combines all the benefits of larger models with its compact and space-saving format. Up to 70 packs per minute are attainable with MAP*, depending on tray type and application.

The ideal entry-level model for high-tech packaging systems for packaging all types of fresh products.

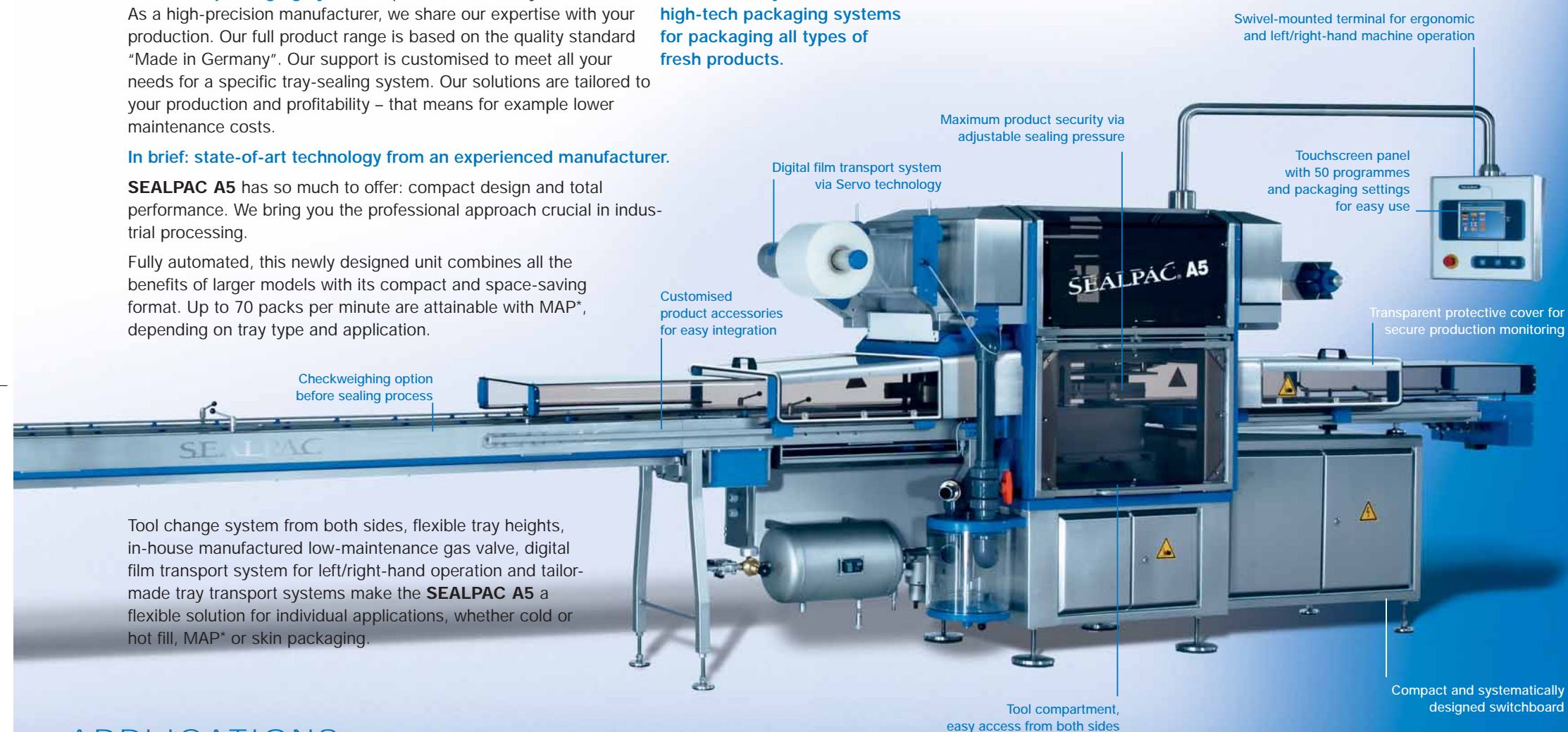

Tool change system from both sides, flexible tray heights, in-house manufactured low-maintenance gas valve, digital film transport system for left/right-hand operation and tailor-made tray transport systems make the **SEALPAC A5** a flexible solution for individual applications, whether cold or hot fill, MAP* or skin packaging.

APPLICATIONS



Fresh food requires fast and reliable processing performance. The **SEALPAC A5** can process all types of sealable materials and is especially suited to all market or product manufacturers at entry level as well as producers of fresh meat and poultry, deep frozen and a large range of convenience foods. **SEALPAC is the optimal packaging solution for your product.**

SEALPAC MAP+ SYSTEM

Faster, fresher packaging, with more appeal!

SEALPAC's exclusively developed vacuum and gas-injection system for packaging fresh food products via MAP* technology.

Use the benefits with the system:

- reduced product exposure
- shorter cycle times
- optimized gas figures
- reduced gas consumption

* Modified Atmosphere Packaging

Guaranteed clean and secure. Excellent operation guaranteed.



SIMPLE
Operation:

Superior design guarantees perfection down to the very last detail. Ergonomic factors for easy handling are crucial process factors.

- Handling via touchscreen
- Left/right-hand operation
- Rapid tool change system with all integrated connections
- Pneumatically adjustable stoppers

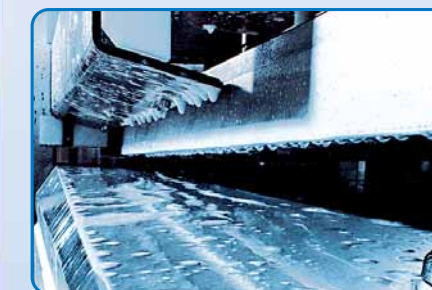

CLEAN
Hygienic:

Food industry requires top hygiene standards for best quality. **SEALPAC** maintains this quality every time via the sustained perfection of our machines.

- Wash down stainless steel frames
- Protection standard up to IP 65
- Self draining hygienic construction
- Complete sanitation without niches



SECURE
Technology:

Our mission is state-of-the-art technology and manufacturing experience: **SEALPAC tray sealing machines** are inspirational and give eye catching innovations to the packaging market.

- Secure guidance for trays in all sequential stages
- Trouble-free integration in existing production lines
- Interface for external communication
- High sealing power
- Proven Sealpac inside cut system