

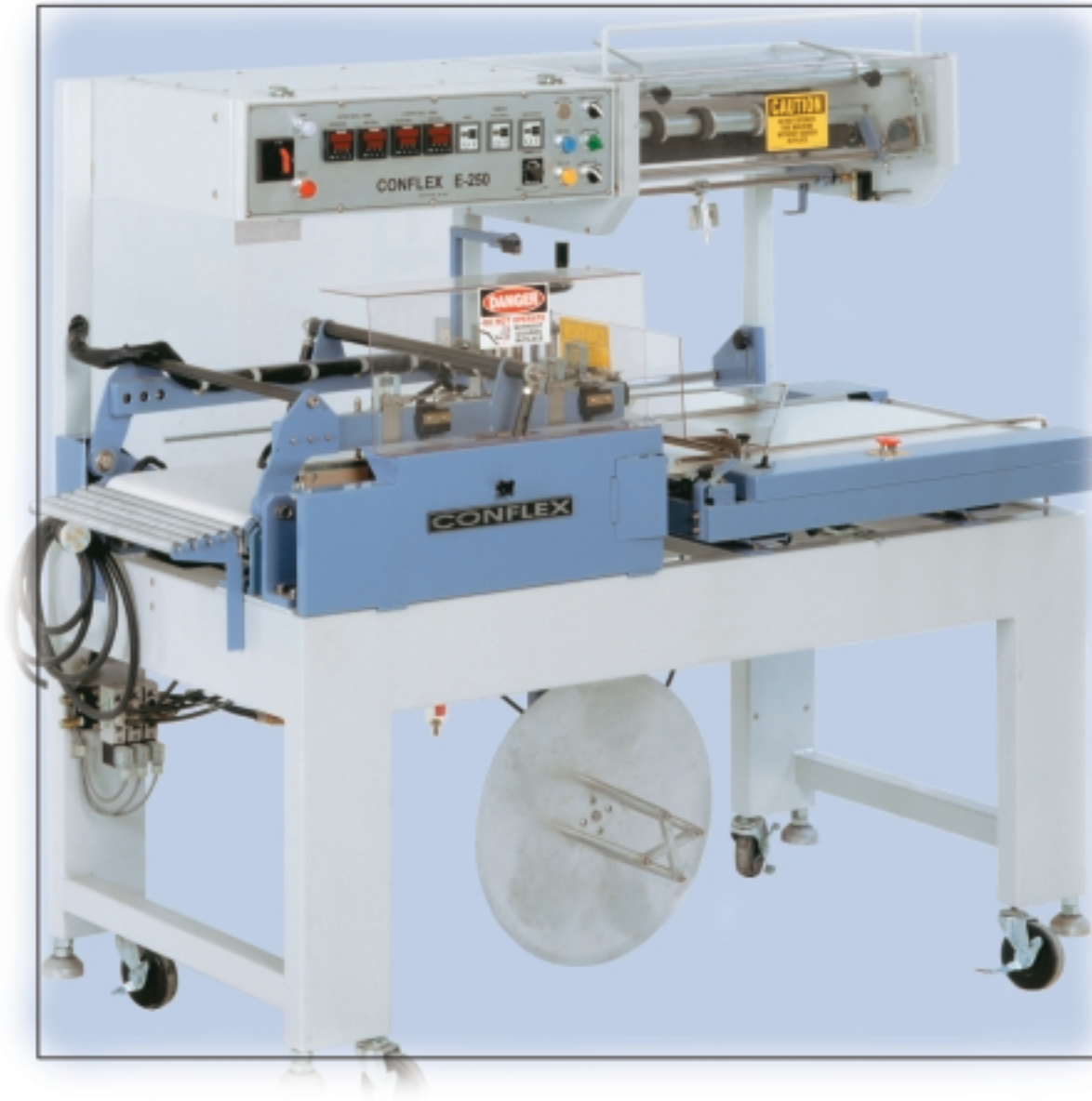

**CONFLEX®**

**E-250**  
Automatic L-Sealer

A "Smart," Proven Performer at an Excellent Value!



**Sealed Air Corporation**

**Packaging - Processing**  
**Bid on Equipment**  
1-847-683-7720  
[www.bid-on-equipment.com](http://www.bid-on-equipment.com)

**Conflex® Shrink Packaging Equipment is precision engineered for optimum performance and reliability. Contact your Conflex distributor to find out more.**

## The Cost-Effective Upgrade You've Been Waiting For!

Fully automatic and engineered for smart performance, the Conflex E-250 L-Bar Sealer is the perfect solution for operations that require a higher level of performance than that of a manual system, but at an economical price. During the sealing cycle, the E-250 "senses" product in its conveyor and temporarily deactivates the belt advance to prevent the next package from entering, facilitating hands-free operation and speeds of up to 30 packages per minute. The E-250...the most efficiency and precision for the price!

## Conflex E-250 Features and Benefits

- **Fully automatic package length adjustments**—Via horizontal or vertical electric eyes; eliminates the need to stop production for adjustments
- **Hot tooled steel knife sealing system**—Eliminates need for wire replacement
- **Lower heated seal pads**—For fast, reliable seals
- **Top mounted control panel**—Provides easy operator access
- **Seals most films**—Polyolefin, PVC and polyethylene
- **Smooth product transfer**—Allows easy wrapping of non-rigid products
- **Film miser/film support bar**—For optimum use and handling of film
- **Small footprint**—A compact 5.5' x 3' size
- **Adjusts to your application**—Features adjustable height legs and casters; hand wheel for product height adjustment
- **Multiple options**—Include wide band seal system, conveyor soft start, film centerfolder, high-speed gearing and more; factory-installed options include closing conveyor, custom infeeds, and more

## Conflex E-250 Specifications

Seal Dimensions	17"W x 22" L
Machine Dimension	65"L x 33"W x 60"H
Net Weight	640 lbs.
Max. Pkg. Ht.	5"
Max. Film Width	20"
Electrical	220V, 16A, 1 ph
Caster Ht.	33-5/8"
Air Requirements (min.)	1 CFM @ 80 psi

## Conflex E-250 Plan View

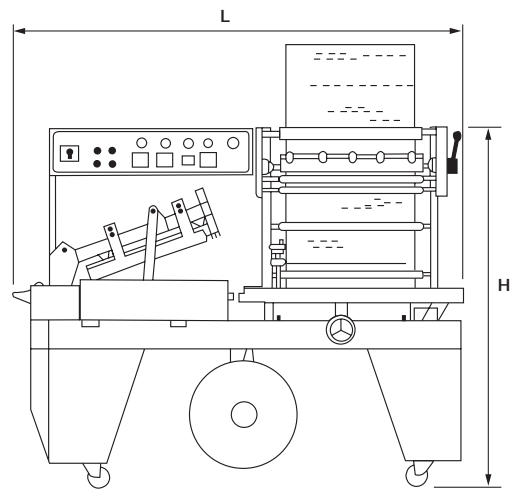

The engineering department is available to customize options for various product applications

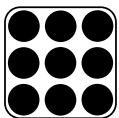

**Sealed Air**

**Shrink Packaging Division**

Conflex Incorporated  
Manufacturing Facility:  
6637 N. Sidney Place  
Milwaukee, WI 53209  
Toll Free: 800-225-4296  
Fax: 414-228-4088  
E-mail: [conflex@execpc.com](mailto:conflex@execpc.com)  
[www.conflex.com](http://www.conflex.com)

**Packaging - Processing**  
**Bid on Equipment**  
1-847-683-7720  
[www.bid-on-equipment.com](http://www.bid-on-equipment.com)