



CX200

Desktop Label Printer



USER'S GUIDE

CX200 User's Guide

Table of Contents

What You Get	1
Controls, Indicators, and Connections	2
Printer Power Connection	2
Printer Interface Connection	4
Setup	4
Loading Labels or Tags	4
Loading Ribbon	6
Sensor Calibration	8
Selecting the Label Sensor Type	8
Using the Printer	9
Printing a Self-test Label	9
Feeding Blank Labels	9
Label Reprint	9
Sending Data to the Printer	9
Printer Ready/Standby/Reset Control	9
Printing Labels	10
Controlling the Printer Using Direct Commands	10
Routine Maintenance	11
What To Do If...	12
READY light is not lit	12
READY light glows red	12
Self-test label will not print	13
Labels will not feed	13
Host stops responding	13
Labels feed continuously	14
Poor print quality	14
Technical Support	14
Printer Specifications	15
Communication Ports	16
Standard Printer Cables	16
Serial Port Parameters	16
CX Software	17
Label Wizard CX	17
Windows Drivers	18
Media and Supplies	18

CX200 User's Guide

ENERGY STAR® COMPLIANCE

The Environmental Protection Agency's Energy Star program promotes the use of energy-efficient equipment, to help reduce pollution and conserve natural resources. As an Energy Star partner, SATO America has determined that the CX200 printers meet the Energy Star guidelines for energy efficiency.



CX200 User's Guide

What You Get

The SATO CX200 Printers come complete and ready to install and print labels. Your CX200 shipping carton contains the following items:

- CX200 Printer
- Parallel Printer Cable
- 40 Watt Power Supply (80 Watt Supply optional)
- Roll of 4"x 4" Labels
- Thermal Transfer Ribbon (not supplied with the CX200DT)
- User's Guide
- CD-ROM Containing
 - Label Wizard CX Label Design and Production Software
 - Label Wizard CX Manual Files
 - CX200 User's Guide
 - CX200 Programming Reference Guide
 - Windows Printer Driver for CX200
 - Label Wizard SE Evaluation Software
 - SATO Product Catalog
 - Adobe Acrobat Reader® for viewing and printing the manuals.
 - CX200 Quick Start Guide



CX200 User's Guide

Controls, Indicators, and Connections

Device Name	Primary Function	Use
FEED Button	Advances print media	PRESS - to advance media PRESS while pressing READY indicator - to print test label PRESS - to pause printing during batch mode operation
READY Indicator ON-OFF Button	Shows printer status Places printer in On-Line or Off-Line mode	GREEN - Printer ready for data OFF - Printer busy, or Off-Line RED - Printer needs attention PRESS to switch to/from Off-Line or to reset the printer
Power Input	Connects to power supply	Connect to transformer provided with printer
Serial Port	Data input	DB9 female connector for connection to host controller, RS232 interface
Parallel Port	Data input	Centronics compatible connector for connection to host controller
Print Head Release	Unlocks print head	Push both releases toward rear of printer to release print head
Top Cover	Protects print media and mechanism	Lift to open Push outward at hinge to remove

Printer Power Connection

1. Plug the output of the AC power supply provided with the printer into the connector on the bottom panel.
2. Connect the supply into an AC outlet having the proper voltage.

Note:

CX200 printers consume very little power when idle, so are not equipped with a power switch. Pressing the READY indicator/ON-OFF (a combined control) will reset the printer and switch it from Off-Line to On-Line mode.



Important!

The required AC voltage is marked on the power supply. Confirm that your AC voltage matches the power supply requirements. ***Do not use any power supply other than the one provided with the printer.***

CX200 User's Guide

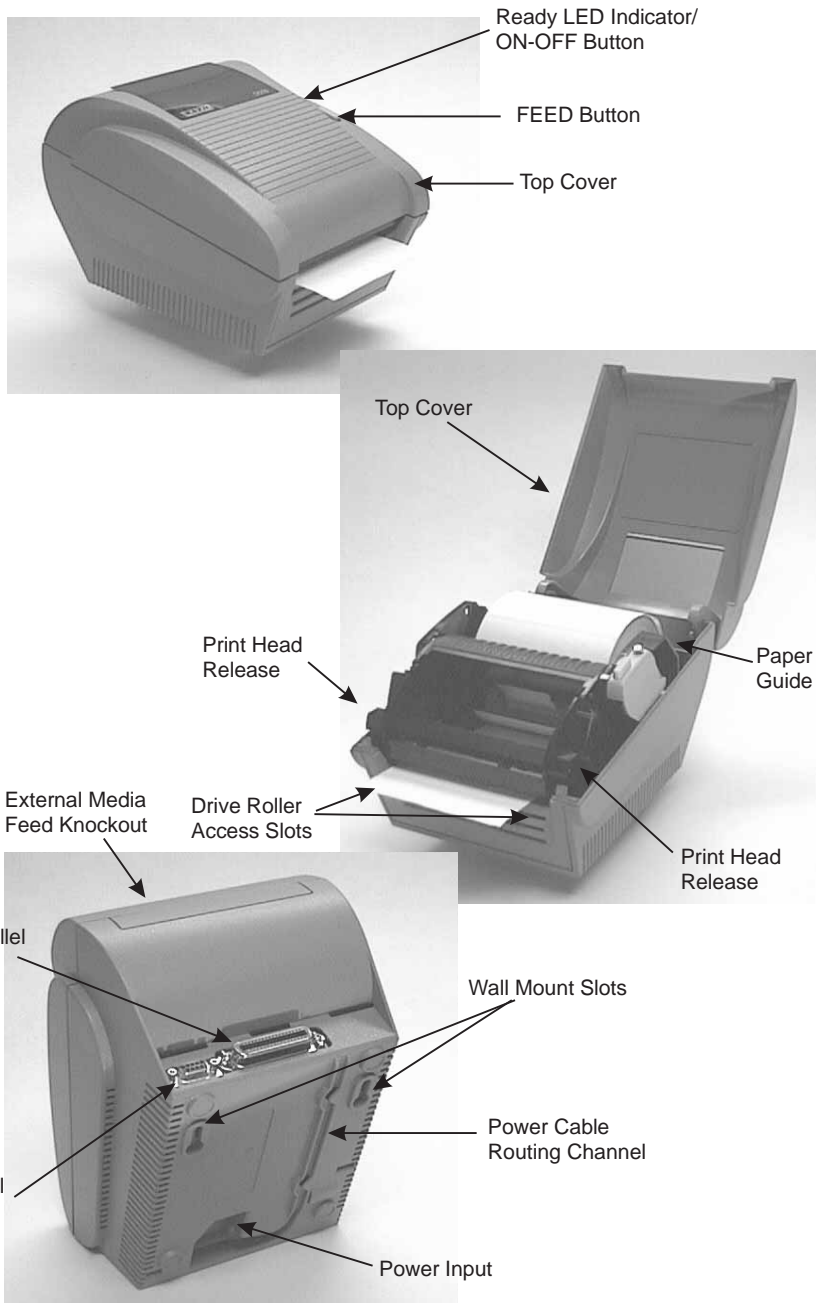

PN 9001050 Rev. B

Page 3

CX200 User's Guide

Printer Interface Connection

1. Connect the supplied interface cable to the parallel printer port on the computer.
2. Connect the other end to the parallel input port on the printer.

Setup

Loading Labels or Tags

1. Lift open the top cover.
2. Press the two print head releases back to unlock the print head.
3. Remove any print media or empty label core from the printer.
4. Unwrap the new media, and unwind a few labels from the roll. Labels should be wound face-in for the best results.
5. Slide the paper guide all the way to the right.
6. Place media roll in the paper tray such that the media unwinds from the bottom of the roll toward the front of the printer. The label imaging surface must face up as it passes under the print head.
7. Lift the print head and slip the free end of the media under the print head.
8. Adjust the paper guide until the media is snug between the paper guide and the left side of the paper tray.
9. Lower the print head and press it down firmly until it locks closed on both sides.
10. Close the top cover.
11. Wait until the Ready Indicator glows green and press the FEED button to feed a label or to resume printing.

CX200 User's Guide

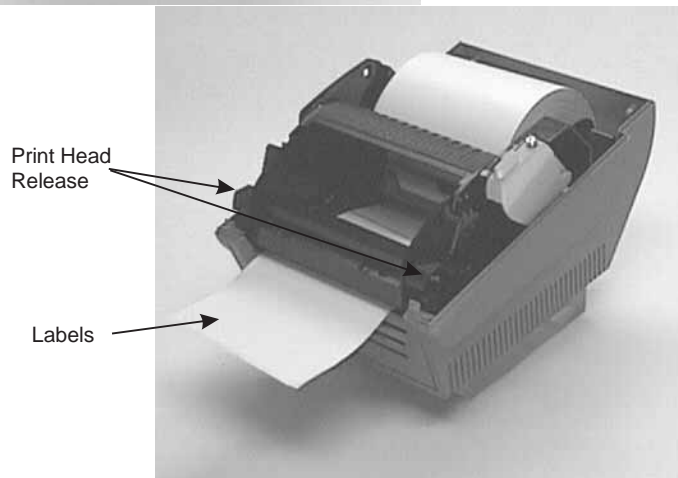
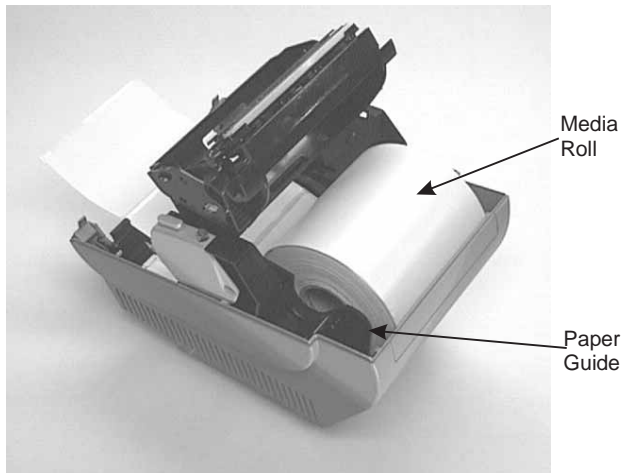
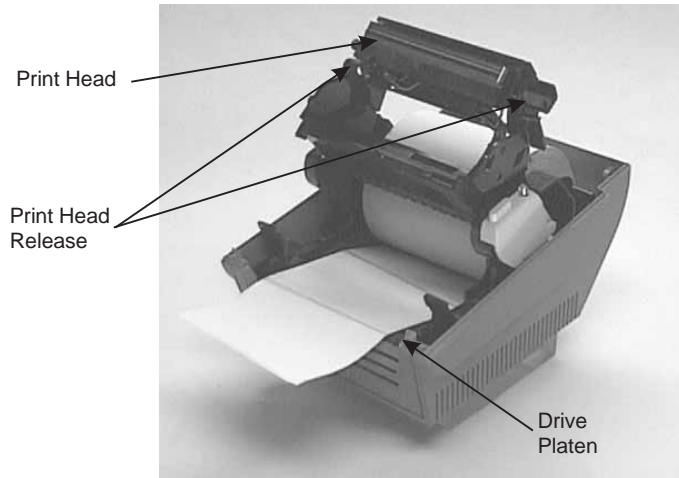

CX200 User's Guide

Loading Ribbon

The CX200TT thermal transfer printer transfers ink from a ribbon to the label to produce an image.

1. Lift open the top cover.
2. Press the two print head releases back to unlock the print head.
3. Unwrap the new ribbon and unwind about 4" from the roll. The end of the ribbon is attached to a take-up core.
4. Observe the notches on both ends of the supply core and the take-up core. These notches must fit on the corresponding nibs on both the supply and take-up spindles.
5. Roll several turns of ribbon on the take-up core, winding to the underside as shown. The dull (coated) side of the ribbon must be on the outside of the take-up roll.
6. Place the take-up core (ribbon unrolling from the top side) into the left take-up spindle. The take-up spindles are the top set of spindles.
7. Pull out the spring loaded knob on the right take-up spindle and place the right end of the take-up core into the right spindle, lining up the notches with the spindle nibs.
8. Pull the ribbon down and over the print head and insert the supply core onto the left supply spindle, making sure the notches in the core fit over the nibs.
9. Pull out the spring loaded knob on the right supply spindle and place the right end of the supply core into the right spindle, lining up the notches with the spindle nibs.

Note:

Make sure the (coated) dull side of the ribbon is to the outside where it will be in contact with the label media.

10. Turn the supply spindle to pull the ribbon over the print head without any slack. Check to make sure there are no ribbon wrinkles.
11. Lower the print head and press it down firmly until it locks closed on both sides.
10. Close the top cover.
11. Wait until the Ready Indicator glows green and press the FEED button to feed a label or to resume printing.

CX200 User's Guide

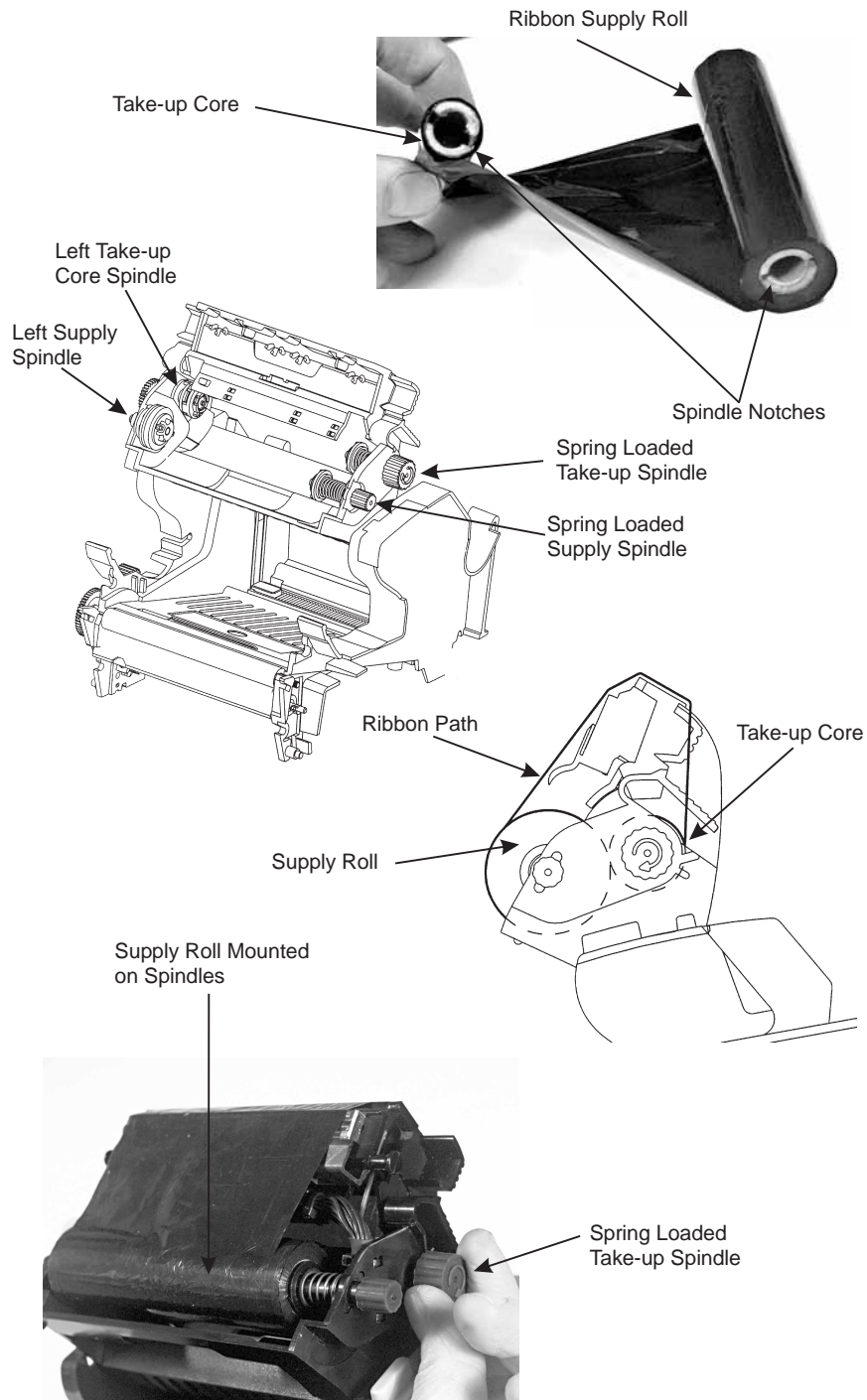

PN 9001050 Rev. B

Page 7

CX200 User's Guide

Sensor Calibration

The CX200 uses a single sensor element for both direct thermal (without a ribbon) and thermal transfer (with a ribbon) printing. The method of printing can be selected for the CX200TT by using configuration settings in the software program or by sending command directly to the printer (see page 92 of the Programming Guide). The mode of operation can be determined by running a Self Test Label (see page 9). The CX200DT direct thermal printer cannot be used for thermal transfer printing since there is no provision for controlling a ribbon and it is always in the Direct Thermal mode. It will ignore any commands that try to set it to the Thermal Transfer mode.

A CX200TT unit is calibrated at the factory for use with SATO Standard ribbon and media. Other ribbon/media combinations may or may not index properly with these settings. If you are experiencing difficulty with label indexing and are not using SATO labels and/or ribbon, it may be necessary to recalibrate the unit for your particular ribbon/media. This can be done by selecting the Calibration buttons provided in the Label Wizard CX software or the CX200 Windows Printer Driver. If you are not using either of these, you will have to send the calibration command directly to the printer. See the Programming Guide, page 86, for instructions on using the Sensor Calibration command.

Important!

The ribbon must be installed in the printer when calibrating in the thermal transfer mode.

Selecting the Label Sensor Type

CX200 printers can use Eye-Mark, gap, or notch label sensing. The sensing method used by the printer must match to the media being used. If you are using label printing software, it should provide a means to set up these parameters. See your software documentation for details. If you are writing your own software or controlling the printer using direct commands, you must use printer commands to set up the print mode and sensing method. Refer to the programming information provided in the Program.pdf file for further information.

Note:

The Program.pdf file is in Adobe Acrobat format. To view it, you must install Adobe Acrobat Reader which is included on the CD-ROM in the AcroRead directory.

CX200 User's Guide

Using the Printer

Printing a Self-test Label

Printing a self-test label checks the printer's overall operability. To run a self-test, confirm that the printer is loaded and connected to AC power and no print jobs are in process. Then:

1. Press and hold in the READY Indicator.
2. Press and release the FEED button.
3. The printer should begin printing a self-test label. Release the READY indicator after printing starts.
4. After the self-test label finishes printing, press the READY indicator twice to reset the printer and restore normal operation.

Important!

The printer will be in hex dump mode after printing the self-test label. It cannot print normal labels in hex dump mode. The printer will return to normal operation after you reset it as described in step 4 above.

Feeding Blank Labels

To feed a label, press and release the FEED button with the printer Off-Line. Press and hold in the FEED button to feed multiple labels.

Label Reprint

If the last label printed has not been cleared from the print buffer by pressing the READY indicator to take the printer Off-Line, then pressing the FEED button will cause the last printed label to be reprinted.

Sending Data To the Printer

To print labels using data sent from a host computer or terminal:

1. Connect the host and printer serial or parallel ports together using a correctly wired interface cable (see page 16 for wiring information).
2. If you are using the serial port, confirm that the host and printer are using the same communications parameters.
3. Confirm that the READY indicator is glowing green.
4. Send your data to the printer.

Printer Ready/Standby/Reset Control

The CX200 does not have a power switch, but you can effectively turn it "off" by pressing the READY indicator. This resets the printer's microprocessor and places the printer in Off-Line. Resetting the microprocessor will:

CX200 User's Guide

- stop any printing.
- delete the label format in process from memory.
- reset the printer communication ports.
- return all printer parameters to their default (first power-on) state.

Pressing the READY indicator a second time will return the printer to On-Line mode (its default condition). Resetting the printer in this manner does not harm it in any way, nor does it affect the contents of nonvolatile RAM or remove any stored objects. The effect is the same as if you had unplugged and reconnected the printer power supply.

Printing Labels

To print labels, the host computer sends commands to the printer via the serial or parallel communications port. If you are using the Label Wizard CX label printing software supplied on the CD-ROM, the computer and software control the entire printing process. You only need to set up the printer, start your label printing program, and follow its instructions. If you are using another vendor's software package, contact the software supplier or manufacturer if you encounter difficulties. A complete Reference Manual for the Label Wizard CX label design and printing software is included on the CD-ROM. If you want to print labels from another Windows application, the CX200 Windows Printer Driver must be installed. It is found on the CD-ROM and must be loaded using the standard Windows printer installation instructions.

Controlling the Printer Using Direct Commands

You can also produce labels by sending commands directly to the printer. Simple ASCII commands control the printer. You can write command files using any text editor program that can output ASCII text (including the control codes). Since printer programming is potentially complex, programming information is not provided here. A printer command reference and basic programming procedures are provided on the CD-ROM packed with the printer. The file CXManual.pdf on the disk is in Adobe Acrobat format, readable using the Adobe Acrobat Reader provided in the AcroRead directory on the CD-ROM or can be downloaded free of charge from <http://www.adobe.com>. This program will allow you to search the contents of the manual and/or print a hard copy. If you need programming information and are not using Windows (or cannot read the CXManual.pdf file for any other reason), contact our Technical Support department for assistance (please see page 14 for contact information).

CX200 User's Guide

Routine Maintenance

SATO America printers need very little maintenance other than occasional cleaning. Clean the printer body as required, using soft cloth moistened with a mild detergent cleaner. Clean the print head if it appears dirty or if print quality is poor. Print head cleaning is easy and fast:

1. Unlatch and raise the print head if it is not already raised and latch it in the open position.
2. Using a SATO Direct Thermal Print Head Cleaning Sheet or a soft cloth moistened with 99% pure isopropyl or denatured alcohol, clean all dirt and label residue from the print head, paying particular attention to the "burn line" (this is the thin black line near the front edge of the print head).

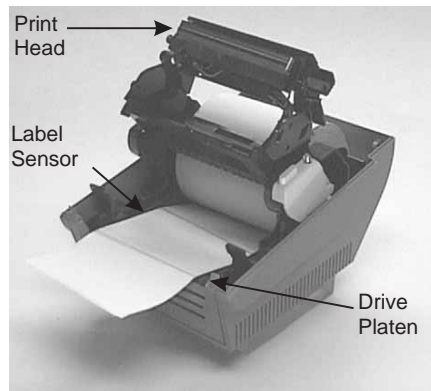

Caution!

Do not clean the print head or drive roller using abrasive or metallic objects, ammonia-based cleaners or other harsh chemicals. These practices can cause serious damage and will void the warranty.

3. Wipe the drive roller with the cleaning cloth. To reach all portions of the drive roller, press the FEED button. The roller will rotate 1/4 turn each time you press the FEED button.

Caution!

Keep all objects clear of the drive roller when you press the FEED button.

4. Confirm that the label sensor is unobstructed. Clean away any obstruction with a soft brush if necessary.
5. Resume the media loading procedure, or if there is already media in the printer, lower and lock the print head.
6. Resume normal operation.

CX200 User's Guide

What To Do If...

SATO printers are very reliable, so printing problems are unlikely. If you do think you have a printer problem, proceed as follows:

1. Confirm that the printer has the right media installed, and that it is loaded correctly. See page 4 for media loading instructions.
2. Confirm that the printer is connected to its power supply and the supply is plugged into an AC outlet having the proper voltage.
3. Open the print head and inspect the media path. Remove any obstructions, and clean the print head and drive roller according to the instructions on page 11.
4. Press down firmly on both print head latches to confirm that they are closed.
5. Confirm that the printer READY indicator glows green.
6. Print a self-test label as described on page 9.
7. Press FEED to confirm that the printer will feed a label.
8. Review the common problems described in the following section.
9. If these steps do not correct the problem, contact your SATO America dealer or our Technical Support Department. You will find Technical Support contact information on page 14.

Note:

The information here assumes you are using label printing software. If you are programming the printer, please review the information in the CXManual.pdf file located on the CD-ROM.

Common Problems And Their Solutions

READY light is not lit

Double-check the AC source and the power supply connections. Disconnect the cable between the printer and host, then reset the printer as described on page 8. If the READY light glows green with the host disconnected, suspect a host computer or cabling problem.

READY light glows red

1. Press the FEED switch to assure that the printer is not paused in batch mode printing.
2. Confirm that the print media is not exhausted.
3. Confirm that the print head is securely latched down on both sides.

CX200 User's Guide

4. If you have been printing many labels, the printer may have overheated. Normal operation will resume after the printer has cooled sufficiently.

Self-test label will not print

1. If printing in the direct thermal mode, confirm that you have loaded direct thermal media.
2. Disconnect the cable between the printer and the host computer. Reset the printer as described on page 10. Then try to print a self-test label again.

Labels will not feed

1. Confirm that the print media is loaded correctly.
2. Reset the printer as described on page 10. Confirm that the printer LED indicator glows green. Press the FEED button.
3. If the printer still does not feed, disconnect the communications cable and repeat step 2. If the printer feeds with the cable disconnected, suspect a problem with the host computer or cable.

Host stops responding or displays “printer not ready” message

1. Review your software setup, following the instructions provided with the software.
2. Confirm that the host-to-printer communication cable is connected and undamaged. If using the serial port, confirm that you are using a null modem cable or adapter.
3. If using the serial port, confirm that the host and printer are both using the same serial port parameters. The self-test label shows the current printer serial port parameters.
4. If using a communications switch between the host and printer, remove the switch and connect the printer directly to the host.
5. Reset the printer as described on page 10, reset the host computer and software, and try printing again.

CX200 User's Guide

Labels feed continuously

1. Check that the print media is loaded correctly.
2. Confirm that the sensor type (Eye-Mark or gap) in your software setup matches your print media.

Poor print quality

1. Confirm that the print media is properly loaded, and there is no side-to-side motion of the paper as it feeds through the printer.
2. Check your software's print darkness and print speed settings. These settings may need adjustment for optimum results.
3. Try different print media. Old or inferior quality media will degrade print quality.
4. If you are printing in the direct thermal mode, make sure you are using direct thermal labels.

Technical Support

Please contact your local dealer for technical support. Your dealer is knowledgeable about SATO America printers, printing software, and your unique system. If you still need technical assistance on your CX200 after contacting your dealer, 90 days of free telephone support is provided to all users who have returned the filled in registration card. The 90 day period starts with the receipt of your first telephone support call. If you are having difficulty with application software other than that supplied with the printer, please contact the software vendor for support. SATO America cannot provide support for third party software problems.

The Technical Support Department can be reached at 408-745-1379, 8 AM to 5 PM Pacific Time, Monday through Friday, or FAX them at 408-745-1309. If you must return any products to the factory, first obtain a returned material authorization number (RMA) from our Technical Support Department. When calling, please have your printer model number and serial number handy.

Unlimited support for the CX200 is provided via fax at 408-745-1309 or via E-Mail at techsupport@satoamerica.com. Additional troubleshooting information is available in the Tech Tips page at <http://www.satoamerica.com>.

CX200 User's Guide

Printer Specifications

Model:	CX200DT/CX200TT
Print Method:	Direct Thermal/Thermal Transfer
Resolution	203 dpi 8 dpmm
Max. Media Width:	4.65 in. 118 mm
Min. Media Width⁽²⁾:	2.0 in. 51 mm
Max. Print Width:	4.1 in. 104 mm
Max. Print Length⁽¹⁾:	14 in. 356 mm
Max. Print Speed:	3 ips 76 mm/s
Physical Size:	6.6 in. H x 6.9 in. W x 10 in. D 168 mm H x 175 mm W x 254 mm D
Weight ⁽³⁾:	3.1 lb./1.41 kg 1.4 lb./1.63 kg
Installed RAM:	512 KB, non-volatile
Installed ROM:	512KB Flash
Communications:	RS232C Serial and Centronics Parallel
Max. Media Roll OD:	5.0 in. 127mm
Ribbon:	459 ft. (max), 0.5" core, Coated Side Out
Label Sensing method:	Eye-Mark, Gap or Notch, Fixed Position
Min. Form Length:	0.375 in. 9.5 mm
Text fonts:	12 proportional and monospaced fonts, up to 12X expansion
Graphics:	PCX and SATO Hex/Binary
Bar codes:	UPC-A/E, EAN-8/13, UCC/EAN-128, Bookland, Code 39, I 2 of 5, Code 128, Codabar, Plessey, MSI, Code 93, Post- net, PDF417, Maxicode
Rotation:	Text and bar codes can be rotated in four 90° increments
Power:	20-26 VAC 50/60 Hz or 18-26 VDC. 120 VAC 50/60 Hz, 40W supply pro- vided with printer
Environmental:	Operating: 41° to 104° F (5° to 40° C) Storage: -4° to 122° F (-20° to 50° C) RH: 25 to 85% non-condensing

Notes:

- 1. The max label length when using the Forms Overlay feature is 7 inches.*
- 2. Minimum tag width is 2.4".*
- 3. Specified weight is without media.*

CX200 User's Guide

Communication Ports

CX200 printers are equipped with Centronics parallel and RS232C communication ports, wired as shown below.

Serial Input Connector (DB9S)

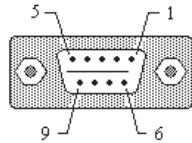

Pin #	Description
2	RXD (data to printer)
3	TXD (data from printer)
5	Ground
7	RTS (printer busy)
8	CTS
1, 9	+5VDC, 200 mA max.

Parallel Input Connector (Centronics 36 pin)

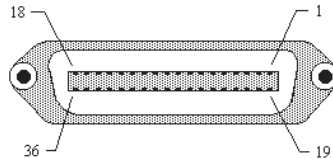

Pin #	Description
1	Strobe
2-9	Data bits 0-7
10	Acknowledge
11	Busy
12	Out of Paper
13	+5DC
17	Chassis Ground
31	Reset
32	+5VDC
16, 33 19-30	Signal Ground

Standard Printer Cables

The following standard cables are available for CX200 printers:

Centronics Parallel Cable, 6 ft.:	Order PN 14S000132
RS232 Cable, DB9M to DB9F, 6 ft.:	Order PN 14S000133
RS232 Cable, DB9M to DB25F, 6 ft.:	Order PN 14S000134

Serial Port Parameters

CX200 printers are configured as Data Terminal Equipment (DTE) equipment, and use Request-To-Send/Clear-To-Send (RTS/CTS) handshaking or XOn/X-Off flow control (control characters are DC2 and DC4). The serial port supports the following parameters:

Speed:	600, 1200, 2400, 4800, 9600, or 19200 Baud
Parity:	Odd, Even, or None
Data Bits:	7 or 8 bits
Stop Bit(s):	1 or 2 bits
Default parameters:	9600 baud, no parity, 8 data bits, 1 stop bit

CX200 User's Guide

Note:

CX200 printers require a "null modem" cable (pins 2-3 and 7-8 cross connected) when connected to another DTE device such as a personal computer. The SATO serial cables are wired in a null modem configuration. Other cables may require an external null modem adapter.

CX200 Software

Two basic software packages are supplied on the CD-ROM included with each CX200 printer. Each package allows you to easily change the configuration of the printer and print labels.

Label Wizard CX

Label Wizard CX is a full-featured label design and production software package. It supports only the CX200 and cannot be used with other SATO America printers. Windows 3.1 or Windows 95 must be installed and operating on your computer to use the software. You can upgrade to the complete Label Wizard PRO package that supports all SATO America printers, including the CX200. Please contact your dealer for upgrade information. To load the software, place the CD-ROM in your CD drive and then select RUN from the Start Menu. Enter X:\CXWizard\Disk1\Install (where X is the drive letter associated with your CD drive). Follow the instructions on the screen. After the software has been installed, you must then install the SATO Generic printer using the Add New Printer selection in the Printer Folder. When asked for the disk with the driver, enter C:\CXWizard\Drivers\Win3X95 as the location of the driver.

Label Wizard CX stores the printer configuration with each label format. When you enter the program for the first time, a Label Definition dialog box is opened. You enter the basic information about your label (width, length, etc.) in this box. Selecting the Printer button in the lower right corner will take you to the Advanced Printer Setup dialog box.

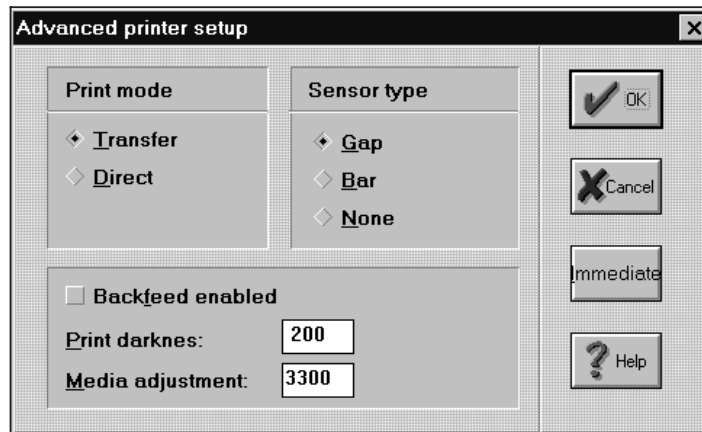

CX200 User's Guide

Selecting Immediate will bring up the Immediate Commands dialog box allowing you to set the RS232 serial parameters.

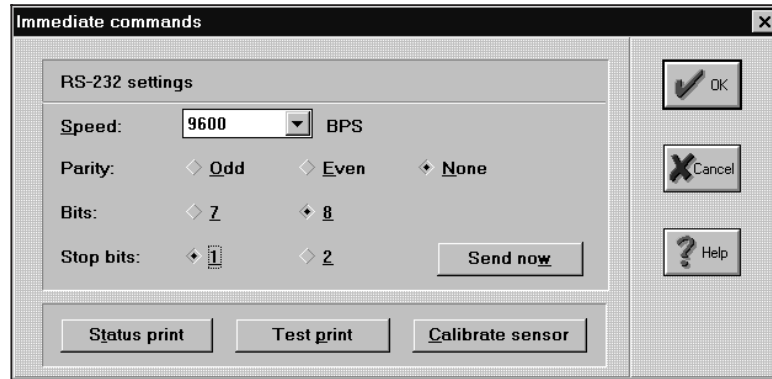

The printer configuration and calibration information is stored in non-volatile RAM. The settings will remain active until new information is sent. The current settings can be verified by printing a test label (page 9). Complete operation and instructions are contained in the CXWizard.PDF file in the Manuals directory on the CD-ROM.

Windows Driver

The CX200 Windows Driver lets you print labels using virtually any Windows application program. The driver is loaded like any other Windows printer. The driver is located in the Windrive directory on the CD-ROM.

After the driver is installed, you can send data to the CX200 just like any other printer on your system: simply specify CX200 in the Print dialog box of your Windows application. Printer configuration is managed using the Advanced dialog box. To print bar codes, you must first define a bar code font using the Barcodes dialog box.

Media and Supplies

The CX200 comes from the factory set up to operate with the SATO media supplies that are shipped with the printer. These supplies have been carefully selected to give optimum results with your printer. Contact Customer Service at 408-745-1300 for ordering information.

Other media supplies may or may not give acceptable results. It is also probable that you will have to calibrate the sensors and heat settings before acceptable results is obtained. Calibration is accomplished by using the Windows Driver or by selection of the Printer button in the Label Wizard CX Label Setup dialog box. Instructions for calibrating the printer for use with different media supplies is contained in the CX200 Printer Programming Guide.