



Promatic Bipak

Vertical continuous and intermittent
motion cartoning machine

Packaging - Processing

Bid on Equipment

1-847-683-7720

www.bid-on-equipment.com

 **Romaco**
EXCELLENCE THROUGH INNOVATION



Code embossing



Spoon feeding

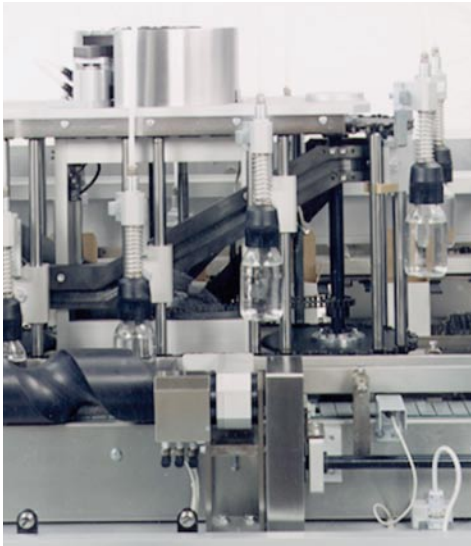

Vial feeding in continuous mode



Vial feeding in intermittent mode

Bipak

two cartoning machines in one

The Promatic Bipak vertical cartoning machine is versatile, flexible and reliable. Depending on the production needs or the application, the machine can be used in continuous or intermittent mode by means of a simple selection on the control panel.

The standard Bipak model is suitable for manual feeding. It can be equipped with a wide range of automatic feeding units to transform it into a fully automatic cartoning machine capable of producing up to 110 cartons/minute.

The automatic feeding of products through the continuous motion pick & place unit (speed up to 100 products/minute) is designed to deliver high efficiency in volume production of upright products such as vials and jars. Ancillary devices such as product security systems are easily accommodated.

The Venturi vacuum unit minimizes noise levels in operations such as carton pick-up and opening or leaflet/booklet feeding.



Bipak

Main Features

- Ultimate flexibility and productivity in a wide range of cartoning applications
- Used for production with frequent carton size changeovers
- Fitted with standard size parts for handling the entire dimensional range of cartons
- Ergonomic manual product feeding area, giving access for up to four operators
- Handles tuck-in, hot glue or both glue + tuck-in (tamper evident) carton closing systems

Key Benefits

- Long service intervals and minimal intervention times
- Fast and easy size changeovers
- Suction cups deliver guaranteed carton opening with minimal risk of crushing
- Wide range of options for automatic feeding
- Selection of continuous or intermittent operation via control panel



Bipak

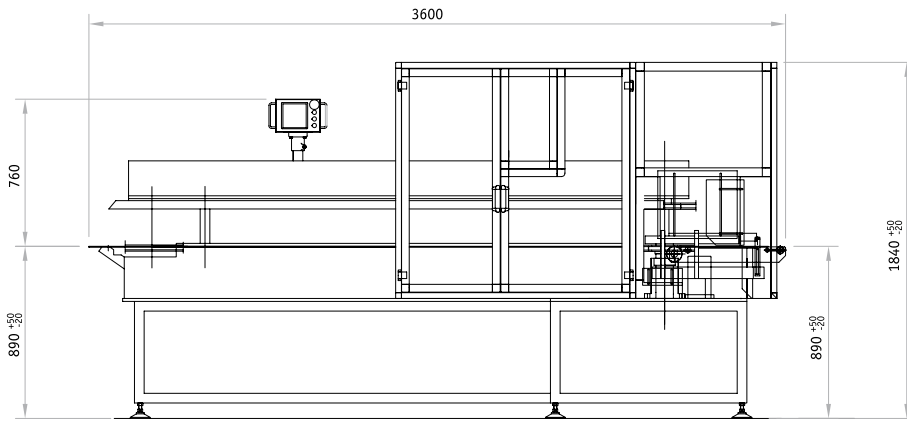

Key Technical Data

	Bipak	Bipak S
Mechanical speed (intermittent motion)	50	45
Mechanical speed (continuous motion)	120	100
Power consumption, in kW	2	2
Air consumption (NI/1')	50	50
Weight approx., in kg	1.350	1.450
Length, in mm	3.600	4.200
Depth, in mm	1.845	2.080
Height, in mm	1.840	1.860
Size range	A (min – max), in mm	20 – 120
	B (min – max), in mm	18 – 80
	C (min – max), in mm	50 – 250

A complete package

Promatic is a recognized world leader in the manufacturing of cartoning and case packing, with a host of firsts and innovations to its name. Flexibility and ergonomics are the fundamental design principles in evidence

right across the product range. Every Promatic cartoner and case packer is engineered to minimize downtime, from advanced product and transport groups, to easy format change and low maintenance requirements.

Promatic provides both horizontal and vertical cartoners with both intermittent and continuous motion. Promatic guarantees high versatility to handle every product, with standard or customized feeding systems.

Romaco
Promatic

Romaco S.r.l.
Via Marzabotto, 5
40065 Pianoro Bologna – Italy

Phone +39 051 620 2611
Fax +39 051 620 2600

promatic@romaco.com
www.romaco.com

A Unit of Robbins & Myers, Inc.

Paper and printing ink from sustainable sources

Packaging - Processing
Bid on Equipment
1-847-683-7720
www.bid-on-equipment.com