



Macofar LVI Series

Liquid Filling Machines

Packaging - Processing

Bid on Equipment

1-847-683-7720

www.bid-on-equipment.com

 **Romaco**
EXCELLENCE THROUGH INNOVATION



Transport system by starwheels



Feeding pumps



Rubber stopper unit

Highest flexibility and highest performance

Macofar LVI 4 / LVI 6

An intermittent motion monobloc liquid filling machine with one closing station, the Macofar LVI. It can be equipped with four (LVI 4) or six (LVI 6) volumetric syringes for filling liquids into glass or plastic containers of any shape. Capping is performed with one or two closing stations capable of handling a wide range of closures such as droppers, spray pumps, press-on plugs, alu-ROPP, plastic screw cap (including child proof) and many others. Simplicity of construction, easy maintenance and quick size parts changeover allow maximum production efficiency at minimum running cost. These machines can be seamlessly integrated into any liquid filling and packaging line.



LVI Series

Macofar LVI 8 / LVI 12

Designed to fill and apply rubber stoppers to injectable vials, this intermittent motion machine is available in two versions: The LVI 8 has four volumetric syringes (2+2), with additional flexibility for a second closing station for alu-caps and the LVI 12, with six (2+2+2) volumetric syringes.

As with the LVI 4 and LVI 6 models, ease of cleaning, perfect accessibility, quick changeover and low maintenance allow maximum production efficiency at minimum running cost.

These machines are a perfect fit into the Romaco line range, which covers all processes from container washing to case packing.



Key Benefits

- High flexibility and versatility
- Designed to satisfy all filling requirements in the Pharmaceutical, Nutraceutical and Cosmetic sectors
- Fast and easy tool-free changeover using quick-release levers
- Simple cleaning and set-up thanks to complete accessibility of all size parts and filling pumps
- Pre-screwing head for closure with plastic screw caps (LVI 4 and 6 only)
- Optional second closing unit for dropper, spray pump or plug on the same machine base (except LVI 12)
- Positive placement of closures
- Individual manual adjustment of each filling pump (or automatically from control panel as option)
- Suitable for products to be freeze dried
- Accommodates a range of different dosing systems and pumps, depending on product characteristics
- Designed to meet all requirements for sterile dosage, the LVI range incorporates options for laminar flow and remote electrical cabinet

Main Features

- cGMP, GAMP compliance and full validation package available
- All machine groups are height adjustable
- Automatic rejection of vials without closure (option)
- Nitrogen flushing before, during and after filling (option)
- Vertical laminar flow (option)



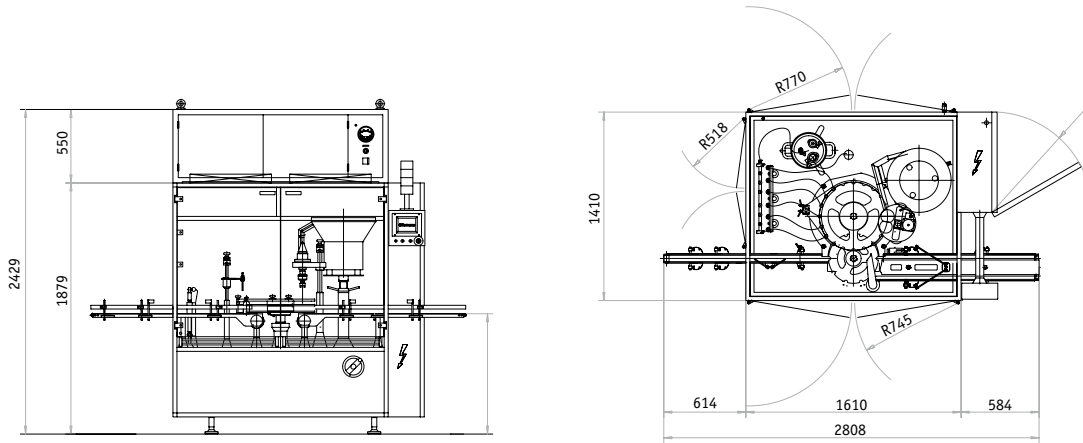

Key Technical Data

	LVI 4	LVI 6	LVI 8	LVI 12
Output (vials/ hour)	4.000	6.000	8.000	12.000–6.000
Fill range	1 ÷ 500 cc.	1 ÷ 350 cc.	1 ÷ 250 cc.	1 ÷ 30 cc. 30–250 CC (6.000 pcs/h)
Vial diameter (min – max), in mm	16–75	16–75	16–52	16–36 36–75 (6.000 pcs/h)
Vial height, in mm	35–200	35–200	35–200	35–200
Rated Power, in kW	5	5	5	5
Compressed air, in bar	6	6	6	6
Net weight, in kg	1.500	1.500	1.500	1.500
Width, in mm	1.410	1.410	1.410	1.410
Length, in mm	2.810	2.810	2.810	2.810
Height, in mm	1.900	1.900	1.900	1.900

Pharmaceutical expertise

Romaco Macofar has built its reputation in over 30 years of outstanding performance, with over 1.800 installations worldwide and an exceptional record in service and support. Macofar is a recognized global

supplier of capsule fillers, liquid fillers, powder microdosing machines, powder macrodosing machines, aseptic liquid fillers, vial and ampoules washing machines as well as sterilization tunnels.

Macofar is the expert partner to assist any pharmaceutical company in the process of installing a new aseptic filling line, from feasibility study to validation. Our Romaco Macofar team is looking forward to the next challenge.

Romaco
Macofar

Romaco S.r.l.
Via Marzabotto, 5
40065 Pianoro Bologna – Italy

Phone +39 051 620 2611
Fax +39 051 620 2600

macofar@romaco.com
www.romaco.com

A Unit of Robbins & Myers, Inc.