

Drive module

RE 51145/06.05
Replaces: 09.02

1/14

Type UPE 5

Component series 1X
Maximum operating pressure 250 bar
Drive power 2.2 to 4.0 kW

H7328

Table of contents

Contents	Page
Features, possible applications	1
Function, section, symbols	2
Ordering code, standard types	3
Technical data, hydraulic	4
Selection table for pump and electric motor	4, 5
Electric motor:	6
• Technical data	
• Electromagnetic compatibility of apparatus (EMCA)	
• Terminal assignment	
Unit dimensions	7, 8
Fill and draw-off volumes	9
Sound pressure level	10, 11
Oil/air cooler	11, 12
Level switch (option)	12
• Function	
• Terminal assignment	
• Technical data	
Temperature switch (option)	12
• Function	
• Terminal assignment	
• Technical data	
Commissioning notes	13

Features

- 100% duty cycle
- Compact design
- Low noise
- High cooling capacity
- Wide field of applications
- Wide variety of variants
- Various mounting options
- Complete hydraulic control possible
- Ready for connection

Possible applications

- Machine tools
- Lifting platforms
- Material handling equipment
- Test benches
- Winding machines

Information on available spare parts:
www.boschrexroth.com/spc

Function, section, symbols

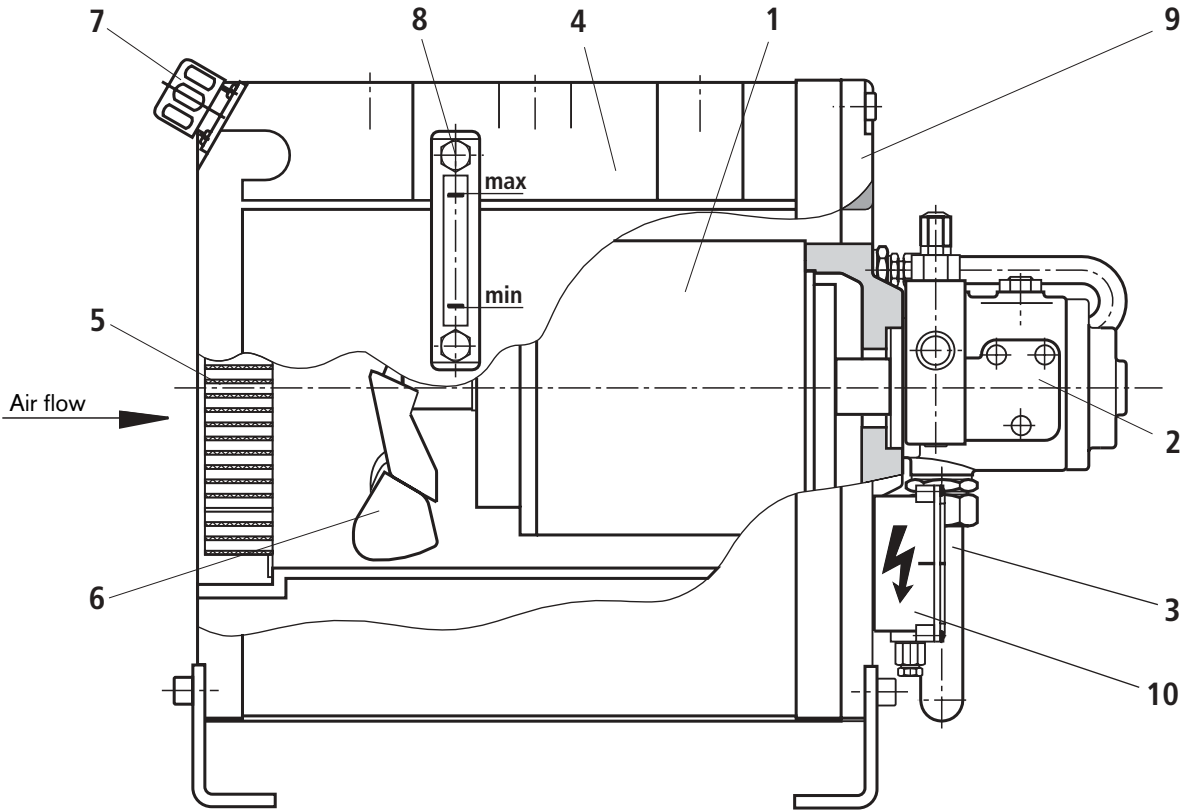

Due to the design concept, drive module type UPE 5 is very compact. Pump (2) is driven with the help of electric motor (1). The electric motor is connected to the pump without a coupling. The shaft of the pump fits into the hollow shaft end of the electric motor. The length of the pump/motor group is therefore held very short. Pump (2) aspirates the hydraulic fluid from tank (4) via suction hose (3) and passes it on to the hydraulic control. The hydraulic fluid returning from the control can be directed via ports K1 and K2 through oil/air cooler (5). The cooled hydraulic fluid is then fed back to the tank. Cold fresh air is aspirated through oil/air cooler (5) with the help of axial fan wheel (6), which is mounted onto the electric motor. This ensures cooling of the hydraulic fluid and of the electric motor. Tank (4) can be filled through filler/breather filter (7). The oil level can be monitored with the help of oil level indicator (8). The tank is

closed with tank cover (9). Pump/motor group (1; 2) and terminal box (10) are fitted to this cover. The drive module comes ready for connection.

Optionally, the drive module can be equipped with an electrical monitoring feature for the oil level and oil temperature and a complete hydraulic control (see RE 51156) e.g. filter, accumulator and valves.

Oil/water cooling, an oil drip tray in accordance with the German Water Resources Act (WHG), a double pump and an additional tank are available on request.

⚠ Caution! The drive module can heat up during operation → risk of injury!

Symbol for control pump (A10VSO, V7)

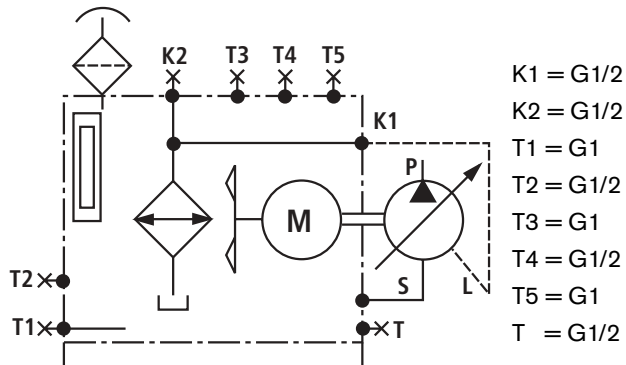

Symbol for fixed displacement pump (GF2, AZ)

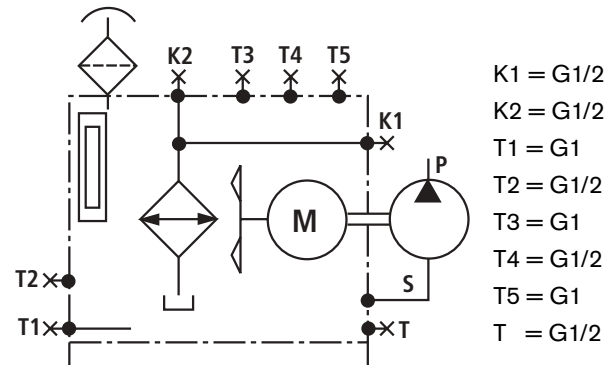

Ordering code

UPE 5-1X/						*
Component series 10 to 19 (10 to 19: unchanged installation and connection dimensions)	= 1X					Further details in clear text
Drive power						Design of the hydraulic control (see RE 51149)
2.20 kW	= 2,2					0 = Without hydraulic control
3.00 kW	= 3,0					1 = With hydraulic control
4.00 kW	= 4,0					
Pumps						Erection variants
Variable displacement axial piston pumps						H = Horizontal mounting
A10VSO10DFR1/52R-PPA14N00 (RE 92713)	= A10VSO10					S = Vertical mounting
A10VSO18DFR1/31R-PPA12N00 (RE 92712)	= A10VSO18					W = Wall-mounting
Internal gear pumps (RE 10213)						Oil monitoring
PGF2-2X/006RE01VE4	= GF2/006					A = Oil level indicator
PGF2-2X/008RE01VE4	= GF2/008					AN = Oil level indicator with level switch
PGF2-2X/011RE01VE4	= GF2/011					AT = Oil level indicator and temperature switch
PGF2-2X/013RE01VE4	= GF2/013					ANT = Oil level indicator with level switch and temperature switch
PGF2-2X/016RE01VE4	= GF2/016					
External gear pumps (RE 10089)						
AZPF-1X-004RAB01MB	= AZ/004					
AZPF-1X-005RAB01MB	= AZ/005					
AZPF-1X-008RAB01MB	= AZ/008					
AZPF-1X-011RAB01MB	= AZ/011					
AZPF-1X-016RAB01MB	= AZ/016					
AZPF-1X-022RAB01MB	= AZ/022					
Vane pumps						
PV7-1X/10-14RE01MC0-16	= V7/10-14					
PV7-1X/10-20RE01MC0-10	= V7/10-20	RE 10515				
PV7-1X/16-20RE01MC0-16	= V7/16-20					
PV7-1X/06-10RA01MA0-10	= V7/06-10					
PV7-1X/06-14RA01MA0-07	= V7/06-14	RE 10522				
PV7-2X/20-20RA01MA0-10	= V7/20-20					
PV7-2X/20-25RA01MA0-10	= V7/20-25					

Standard types: Drive module

Type A10VSO	Material no.
UPE5-1X/4,00A10VSO10A-H-1	R901082362
UPE5-1X/4,00A10VSO18A-H-1	R901082359
Type PGF2	
UPE5-1X/4,00GF2/006A-H-1	R901082363
UPE5-1X/4,00GF2/008A-H-1	R901082364
UPE5-1X/4,00GF2/011A-H-1	R901082366
UPE5-1X/4,00GF2/013A-H-1	R901082368
UPE5-1X/4,00GF2/016A-H-1	R901082367
Type AZPF	
UPE5-1X/4,00AZ/004A-H-1	R901087886
UPE5-1X/4,00AZ/005A-H-1	R901087889
UPE5-1X/4,00AZ/008A-H-1	R901087890
UPE5-1X/4,00AZ/011A-H-1	R901087891
UPE5-1X/4,00AZ/016A-H-1	R901087892
UPE5-1X/4,00AZ/022A-H-1	R901087893

Type PV7	Material no.
UPE5-1X/4,00V7/06-14A-H-1	R901082370
UPE5-1X/4,00V7/10-14A-H-1	R900987391
UPE5-1X/4,00V7/10-20A-H-1	R900987166
UPE5-1X/4,00V7/16-20A-H-1	R904100514

Technical data (for applications outside these parameters, please consult us!)**General**

Weight (without hydraulic fluid and pump ¹⁾)	kg	75
Direction of rotation		Clockwise

Hydraulic

Hydraulic fluid		Mineral oil HLP to DIN 51524 part 2 Please observe our regulations in data sheet RE 07075!
Hydraulic fluid temperature range	°C	-10 to +70 (observe permissible viscosity range of the pump and the valves!)
Viscosity range	mm ² /s	See viscosity range of the pump and the valves
Max. permissible degree of contamination of the hydraulic fluid - cleanliness class to ISO 4406 (c)		Class 20/18/15 ²⁾

¹⁾ For weights of pumps, see RE 10089, RE 10213, RE 10515, RE 10522, RE 92712 and RE 92713.

²⁾ The cleanliness classes specified for components must be adhered to in hydraulic systems. Effective filtration prevents

malfunction and, at the same time, prolongs the service life of components.

For the selection of filters, see data sheet RE 51156.

Selection table for pump and electric motor at $n = 1450 \text{ min}^{-1}$

Variable displacement axial piston pump ³⁾	$q_{V\max}$ L/min	p_{\max} bar	P kW
A10VSO10DFR1/52R-PPA14N00 Max. operating pressure $p_{\max} = 250 \text{ bar}$	15.0	70	2.20
		95	3.00
		125	4.00
	4.0	250	2.20
5.5	3.00		
7.5	4.00		
A10VSO18DFR1/31R-PPA12N00 Max. operating pressure $p_{\max} = 250 \text{ bar}$	27.0	40	2.20
		50	3.00
		70	4.00
	4.0	250	2.20
5.5	3.00		
7.5	4.00		
Internal gear pump	$q_{V\max}$ L/min	p_{\max} bar	P kW
PGF2-2X/006RE01VE4	9.4	110	2.20
		150	3.00
		200	4.00
PGF2-2X/008RE01VE4	11.9	90	2.20
		120	3.00
		160	4.00
PGF2-2X/011RE01VE4	16.0	65	2.20
		90	3.00
		120	4.00
PGF2-2X/013RE01VE4	19.3	55	2.20
		75	3.00
		100	4.00
PGF2-2X/016RE01VE4	23.2	45	2.20
		60	3.00
		80	4.00

External gear pump	$q_{V\max}$ L/min	p_{\max} bar	P kW
AZPF-1X-004RAB01MB	5.8	180	2.20
		245	3.00
		250	4.00
AZPF-1X-005RAB01MB	7.9	130	2.20
		180	3.00
		250	4.00
AZPF-1X-008RAB01MB	11.8	90	2.20
		120	3.00
		200	4.00
AZPF-1X-011RAB01MB	16.0	65	2.20
		90	3.00
		140	4.00
AZPF-1X-016RAB01MB	23.2	45	2.20
		60	3.00
		100	4.00
AZPF-1X-022RAB01MB	31.9	40	2.20
		55	3.00
		75	4.00

³⁾ Up to their maximum values (e.g. A10VSO10DFR1/52R-PPA14N00, $p_{\max} = 250 \text{ bar}$, $q_{V\max} = 15 \text{ L/min}$) the variable displacement axial piston pumps can be operated at optional values (e.g. A10VSO10DFR1/52R-PPA14N00, $p_{\max} = 180 \text{ bar}$, $q_{V\max} = 8 \text{ L/min}$ and $P_{\text{Motor}} = 3.0 \text{ kW}$), provided that the permissible output of the electric motor is not exceeded.

Selection table for pump and electric motor at $n = 1450 \text{ min}^{-1}$

Vane pump ¹⁾	$q_{V\max}$ L/min	p_{\max} bar	P kW
PV7-1X/10-14RE01MC0-16 Max. operating pressure $p_{\max} = 160 \text{ bar}$	21.0	50	2.20
		65	3.00
		90	4.00
	6.5	160	2.20
	9.0		3.00
12.0		4.00	
PV7-1X/10-20RE01MC0-10 Max. operating pressure $p_{\max} = 100 \text{ bar}$	29.0	35	2.20
		50	3.00
		65	4.00
	10.5	100	2.20
	14.5		3.00
19.0		4.00	
PV7-1X/16-20RE01MC0-16 Max. operating pressure $p_{\max} = 160 \text{ bar}$	29.0	35	2.20
		50	3.00
		65	4.00
	6.5	160	2.20
	9.0		3.00
12.0		4.00	
PV7-1X/06-10RA01MA0-10 Max. operating pressure $p_{\max} = 100 \text{ bar}$	14.5	70	2.20
		100	3.00
		100	4.00
	10.5	100	2.20
	14.5		3.00
14.5		4.00	
PV7-1X/06-14RA01MA0-07 Max. operating pressure $p_{\max} = 70 \text{ bar}$	20.0	50	2.20
		70	3.00
		70	4.00
	15.0	70	2.20
	20.0		3.00
20.0		4.00	

Vane pump ¹⁾	$q_{V\max}$ L/min	p_{\max} bar	P kW
PV7-2X/20-20RA01MA0-10 Max. operating pressure $p_{\max} = 100 \text{ bar}$	29	35	2.20
		50	3.00
		65	4.00
	10.5	100	2.20
	14.5		3.00
19.0		4.00	
PV7-2X/20-25RA01MA0-10 Max. operating pressure $p_{\max} = 100 \text{ bar}$	36	30	2.20
		40	3.00
		55	4.00
	10.5	100	2.20
	14.5		3.00
19.0		4.00	

¹⁾ Up to their maximum values (e.g. PV7-1X/10-14RE01MC0-16, $p_{\max} = 160 \text{ bar}$, $q_{V\max} = 21 \text{ L/min}$), the vane pumps can be operated at optional values (e.g. PV7-1X/10-14RE01MC0-16, $p_{\max} = 80 \text{ bar}$, $q_V = 13 \text{ L/min}$ and $P_{\text{Motor}} = 2.2 \text{ kW}$), if the permissible output of the electric motor is not exceeded.

Electric motor

The electric motor is designed according to VDE 0530 part 1 (EN 60034) for the operating mode of continuous operation S1 at nominal power. The electric motor complies with insulation class F and type of protection IP 55.

The electric motor must be connected so that it rotates clockwise (clockwise direction of rotation).

It can be connected to power mains of a frequency of 50 Hz or 60 Hz without any modifications.

Technical data (for applications outside these parameters, please consult us!)

Voltage (other voltages on enquiry)	<i>U</i>	V	400 / 690 ±6% Δ/Y
Frequency	<i>f</i>	Hz	50 / 60
Operating mode	S1 continuous operation		
Insulation class	F (winding)		
Type of protection to VDE 0530 / EN 60034	IP 55		
Number of pins	4		

Frequency 50 Hz

Power kW	Speed min ⁻¹	Power factor cos φ	No. current at 400 Volt
2.2	1440	0.77	5.2 A
3.0	1415	0.76	7.0 A
4.0	1390	0.73	9.8 A

Frequency 60 Hz

Power kW	Speed min ⁻¹	Power factor cos φ	No. current at 400 Volt
2.2	1710	0.84	4.8 A
3.0	1700	0.83	6.4 A
4.0	1680	0.77	9.3 A

Electromagnetic compatibility of apparatus (EMCA)

According to the "Law concerning electromagnetic compatibility of apparatus" (§2, Article 4) and Directive 89/336 EEC the drive module is no equipment that is ready for operation.

To prevent any electromagnetic interference, the use of a suppressor, e.g. type 23 050, 3 x 400 VAC, 50 - 60 Hz made by Murr-Elektronik (D-71570 Oppenweiler) is recommended.

Terminal assignment

Terminal assignment in the terminal box on the drive module In the factory:

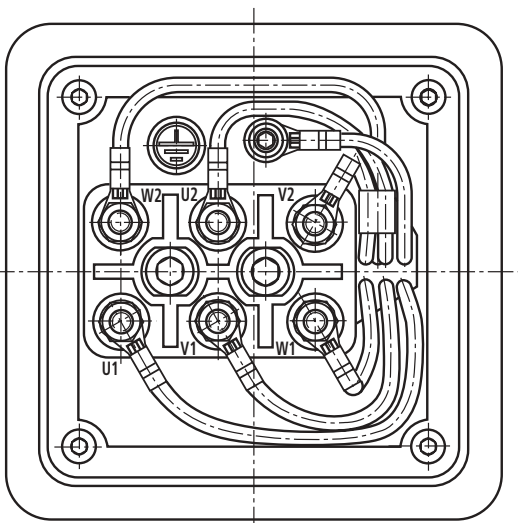

By the customer: Δ star U = 400 V

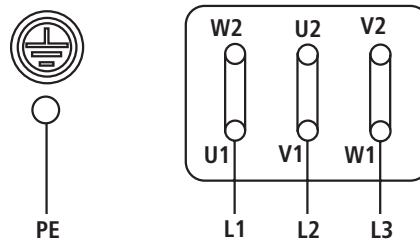

By the customer: Y star U = 690 V

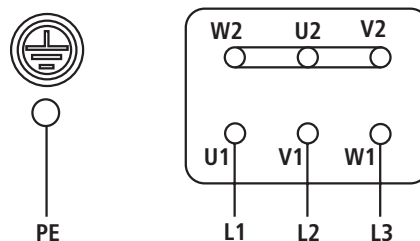

Unit dimensions (nominal dimensions in mm)

Erection variant: Wall-mounting

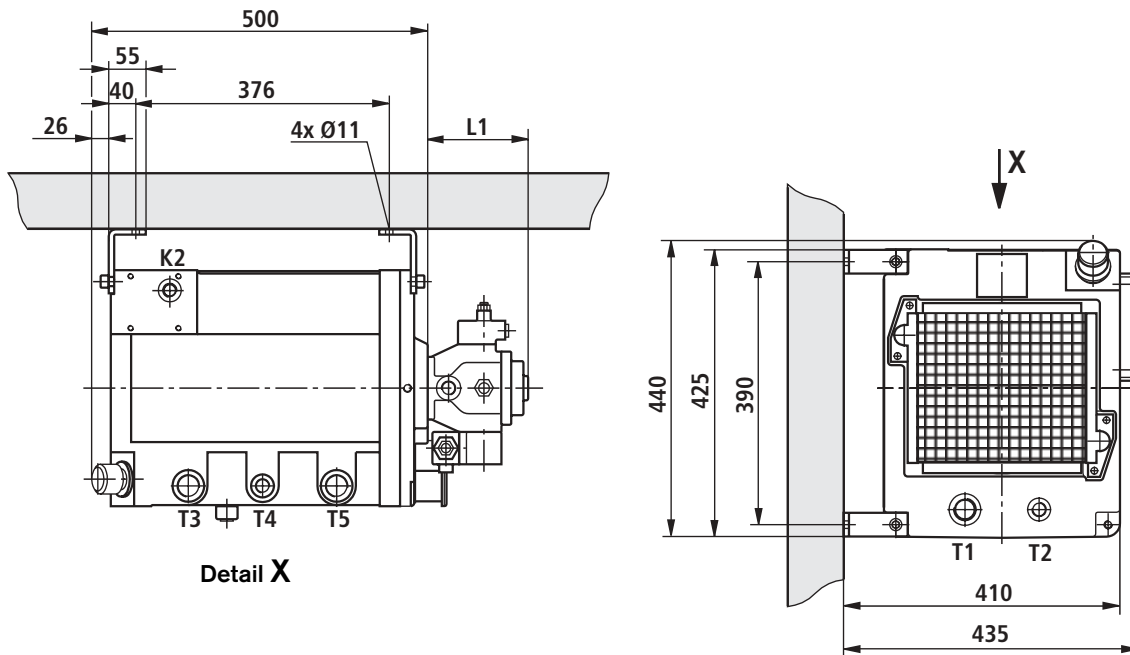

Pump type	Nominal dimensions		
	L1	L2	L3
Variable displacement axial piston pump			
A10VSO10DFR1/52R-PPA14N00	164	725	755
A10VSO18DFR1/31R-PPA12N00	195	705	735
Internal gear pump			
PGF2-2X/006RE01VE4	114	630	660
PGF2-2X/008RE01VE4	117,5	705	735
PGF2-2X/011RE01VE4	123	705	735
PGF2-2X/013RE01VE4	128	705	735
PGF2-2X/016RE01VE4	133	705	735
External gear pump			
AZPF-1X-004RAB01MB	85	630	660
AZPF-1X-005RAB01MB	86	630	660
AZPF-1X-008RAB01MB	90	630	660
AZPF-1X-011RAB01MB	95	630	660
AZPF-1X-016RAB01MB	103	630	660
AZPF-1X-022RAB01MB	115	630	660
Vane pump			
PV7-1X/10-14RE01MC0-16	149	705	735
PV7-1X/10-20RE01MC0-10	149	705	735
PV7-1X/16-20RE01MC0-16	165	725	755
PV7-1X/06-10RA01MA0-10	101	630	660
PV7-1X/06-14RA01MA0-07	101	630	660
PV7-2X/20-20RA01MA0-10	135	705	735
PV7-2X/20-25RA01MA0-10	135	705	735

Fill and draw-off volume (in litres)

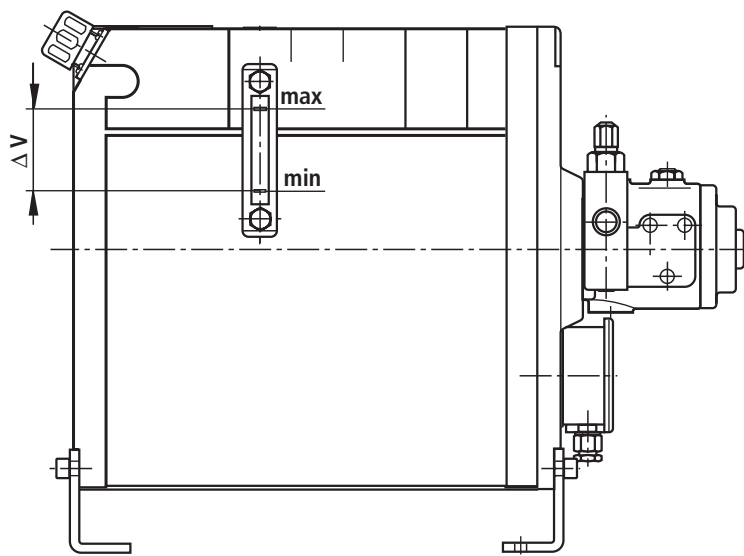

Erection variant: Horizontal mounting and wall-mounting

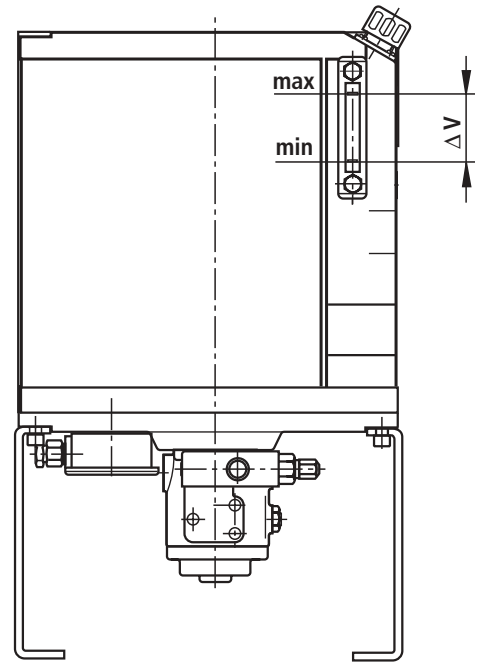

Erection variant: Vertical mounting

	Erection variant: Horizontal mounting and wall-mounting	Erection variant: Vertical mounting
Fill volume	23	26
Draw-off volume	4.5	3.5
Draw-off volume switching point of level switch	3.5	2.0

Sound pressure level (measured at $n = 1450 \text{ min}^{-1}$, $v = 41 \text{ mm}^2/\text{s}$ and $\vartheta = 50 \text{ }^\circ\text{C}$)

Sound pressure level of variable displacement axial piston pump type A10VSO (RE 92712, RE 92713)

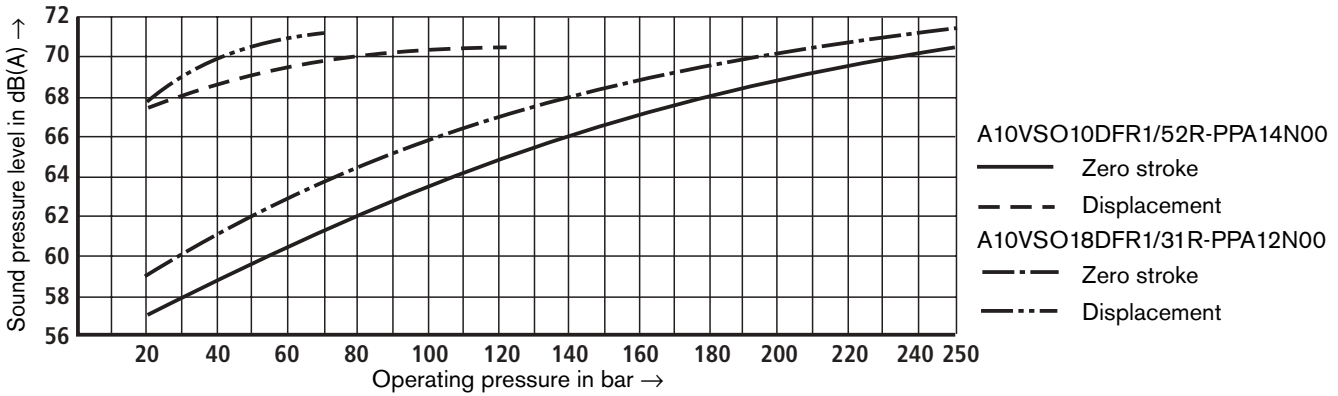

Sound pressure level of internal gear pump type PGF2-2X (RE 10213)

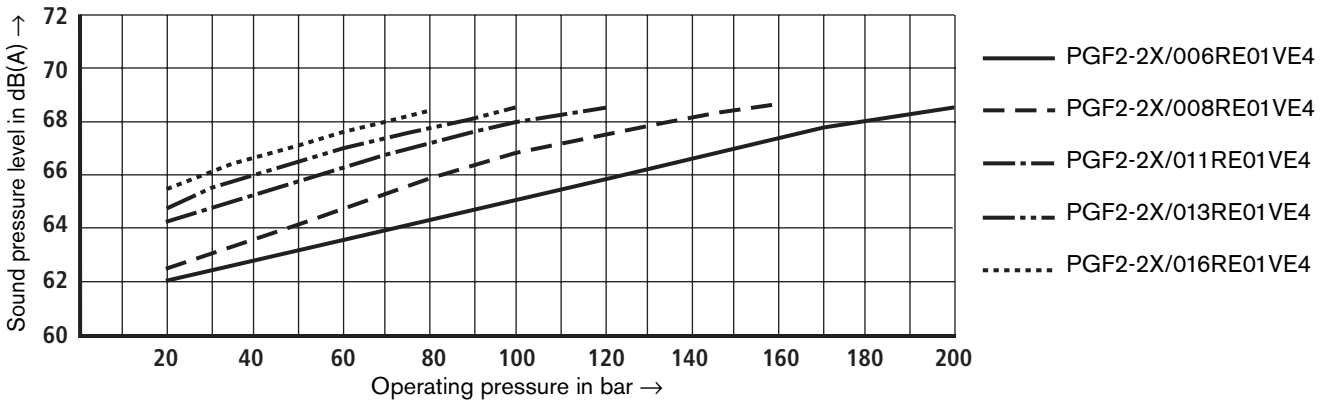

Sound pressure level of external gear pump type AZPF-1X/ (RE 10089)

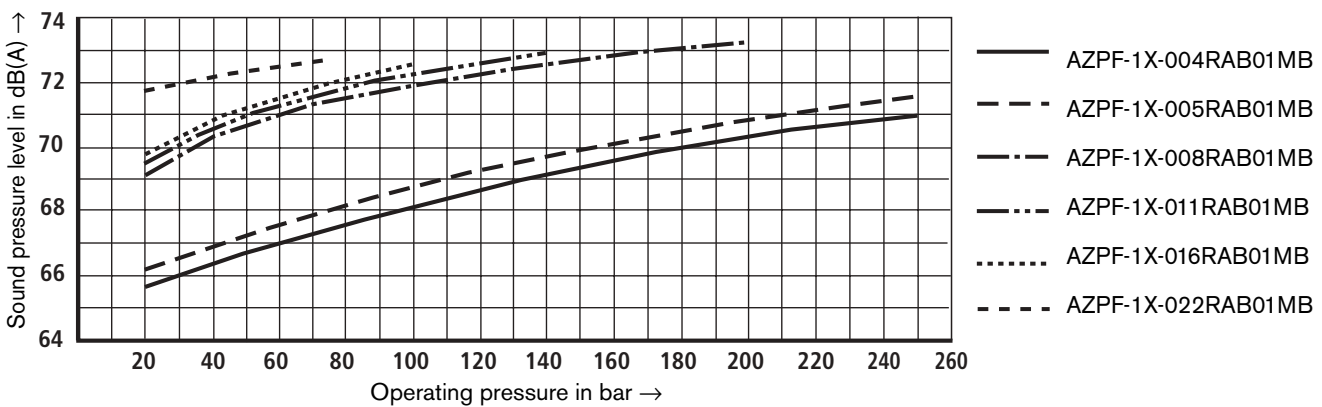

Sound pressure level of vane pump type PV7-1X (RE 10515)

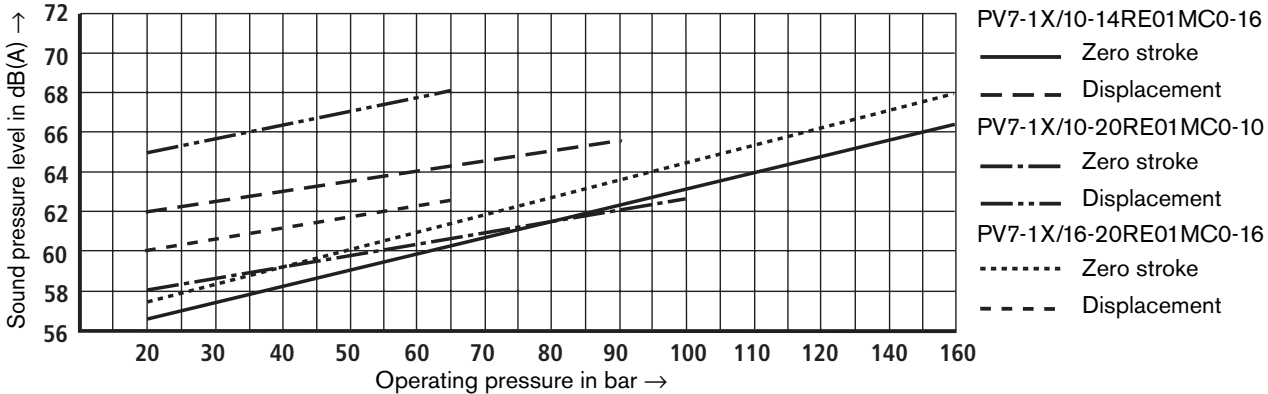

Sound pressure level (measured at $n = 1450 \text{ min}^{-1}$, $v = 41 \text{ mm}^2/\text{s}$ and $\vartheta = 50 \text{ }^\circ\text{C}$)

Sound pressure level of vane pump type PV7-1X (RE 10522)

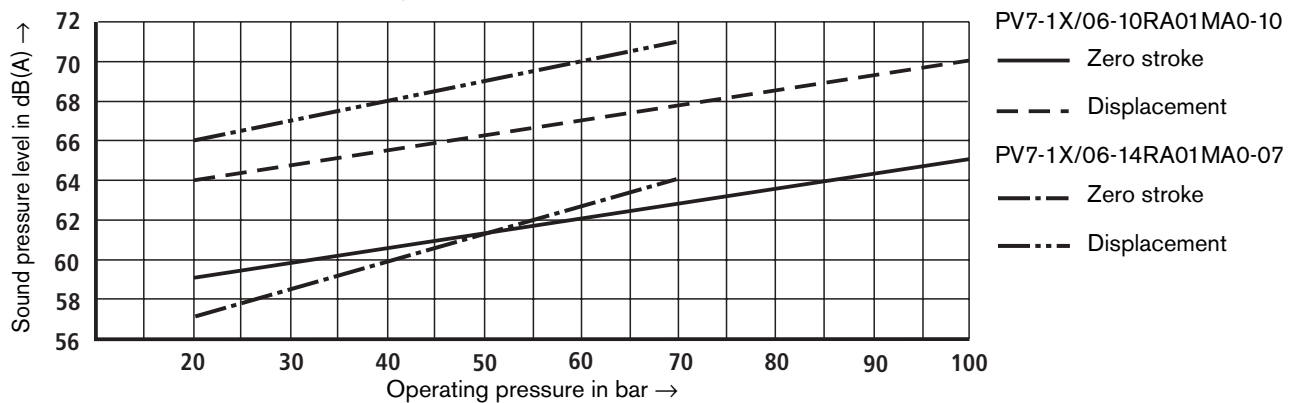

Sound pressure level of vane pump type PV7-2X (RE 10522)

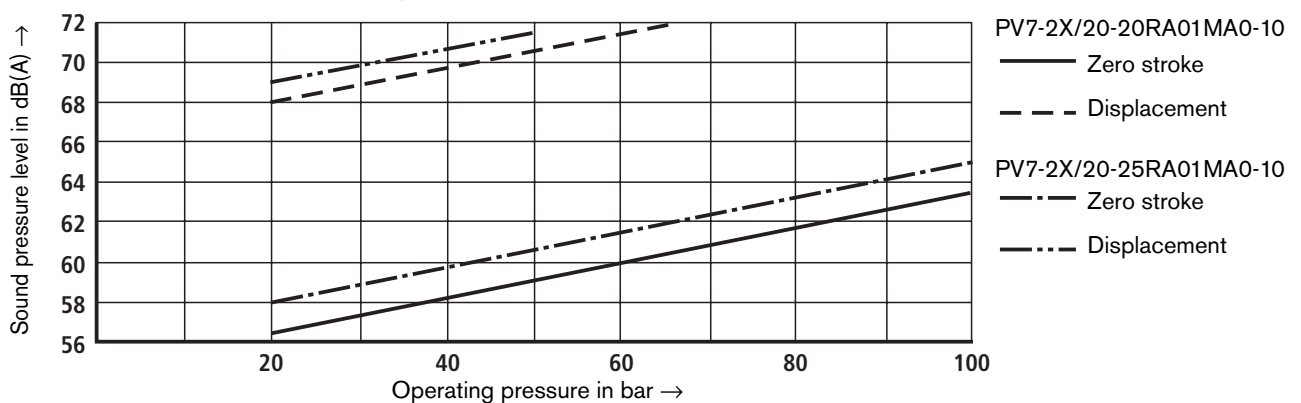

Oil/air cooler ¹⁾

Thanks to the oil/air cooler it was possible to achieve a high power density (ratio of drive power to tank capacity) of the UPE5 drive module.

The drive module with oil/air cooler can therefore be used in continuous operation. The maximum operating pressure of the oil/air cooler is $p_{\text{max}} = 10 \text{ bar}$.

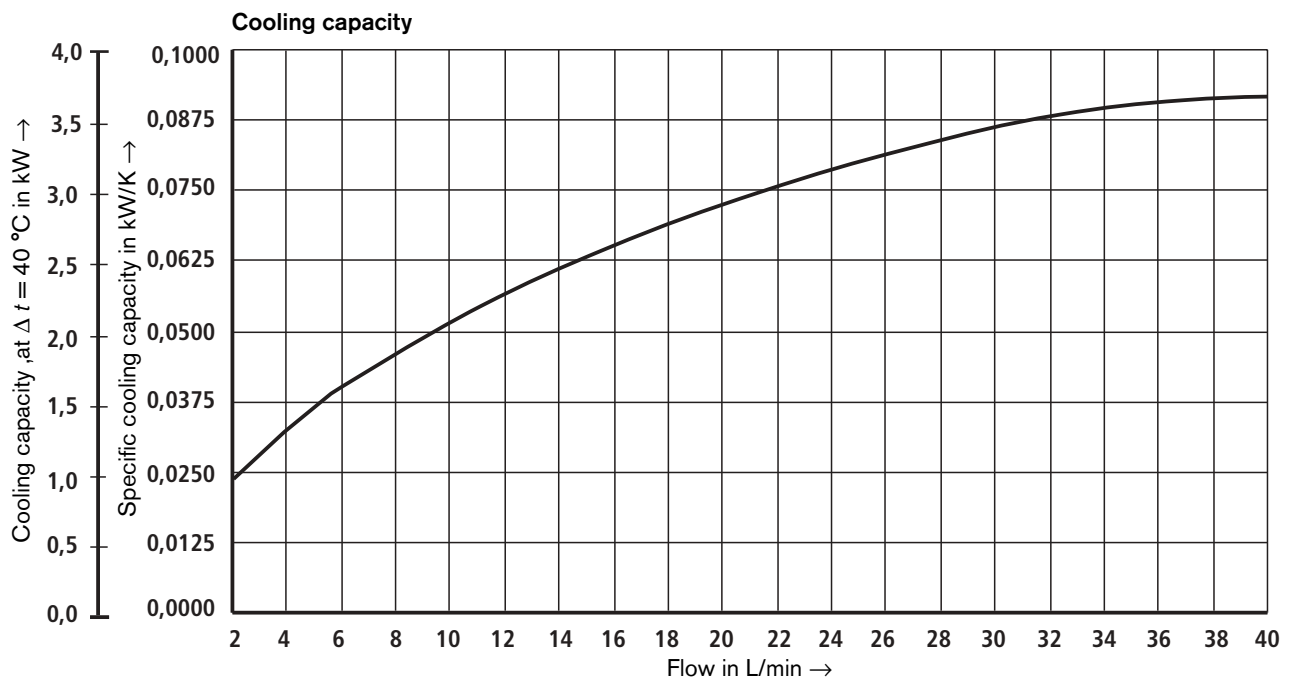

¹⁾ Oil/water cooling possible on request!

$\Delta p - q_v$ characteristic curve (measured at $v = 41 \text{ mm}^2/\text{s}$ and $\vartheta = 50 \text{ }^\circ\text{C}$)

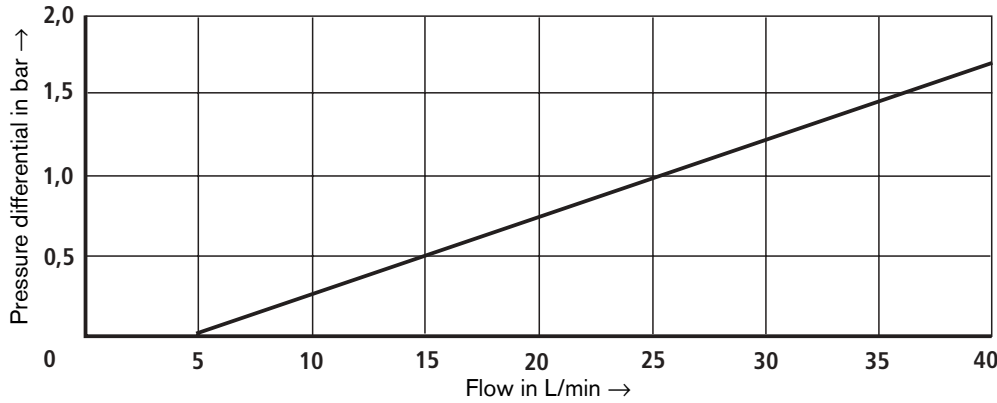

Level switch (option)

Function

The level switch is used to electrically monitor the level of the hydraulic fluid. When the minimum oil level is reached, the con-

tact opens and outputs a signal to the control.

Terminal assignment

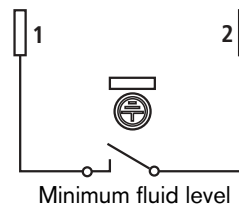
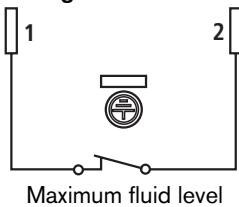

Technical data (for applications outside these parameters, please consult us!)

Maximum voltage	V	50 AC/DC
Maximum current consumption	A	0.25
Maximum power consumption	W	3.0
Type of protection to EN 60529		IP 65
Type of contact		Normally closed

Temperature switch (option)

Function

The temperature switch protects the drive module from operation at impermissibly high hydraulic fluid temperatures. The temperature switch has a firmly set switching point, which is

operated at a hydraulic fluid temperature of 70 °C. The reset hysteresis is approx. 15 K.

The temperature switch is screwed in port T2 in the tank.

Terminal assignment

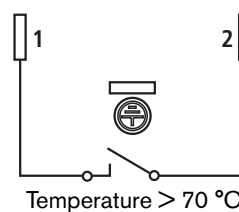
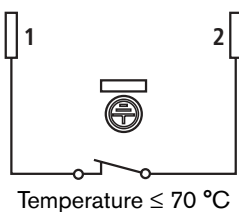

Technical data (for applications outside these parameters, please consult us!)

Maximum voltage	V	230
Maximum current consumption	A	2
Type of protection to EN 60529		IP 65
Type of contact		Normally closed

Commissioning notes

- Check that the drive module is properly connected to the machine to be powered (hydraulic and electrical).
- When connecting the motor, use the washers and connection bridges that are included in the scope of supply.
- The electric motor must be protected by suitable means, which includes an overload relay.
This must be set to the nominal current specified on the nameplate / data label.
- When installing the drive module, strictly observe the direction of rotation, see arrow of direction of rotation. (Practical check: Hold a piece of paper to the cooler. It must be sucked against the cooler.)
- Fill the hydraulic fluid only in through a filter with the required minimum retention rate.
- Only fill the drive module up to the upper edge of the sight-glass.
- Under no circumstances may the pump be operated without hydraulic fluid.

- Let the pump start up under no load and let it displace for some seconds at zero pressure to ensure sufficient lubrication.
- The drive module may only be operated at the permissible data. Moreover, it may only be operated when in flawless condition.
- When carrying out any work on the drive module, depressurise and de-energise the system.
- Unauthorised conversions and modifications that affect safety and function are not permitted.
- Do not remove any protective equipment and guards.
- Observe the generally valid safety regulations and regulations for the prevention of accidents.
- Keep the oil/air cooler clean and do not cover, otherwise, the hydraulic fluid and the electric motor can overheat.
- The operating pressure of the oil/air cooler must not be exceeded.

Note in the sense of EC Machinery Directive 89/392 EEC, Annex II, Section B:

These subassemblies are manufactured to conform with the harmonised standards DIN EN 982, DIN EN 983, DIN EN ISO 12100 and DIN EN 60204-1.

Their commissioning is prohibited until it was confirmed that the machine into which the assembly is to be integrated conforms with the regulations of the EU Directive.

Caution!

The drive module can heat up during operation
→ **risk of injury!**

Adjustments, servicing and repairs of the drive module may only be carried out by authorised, trained and instructed personnel.

Use only genuine Bosch Rexroth spare parts for repairs!