

External gear pump Series G

RE 10 093/08.07

AZPG-22

Fixed pumps
 $V = 22.5 \dots 63 \text{ cm}^3/\text{rev}$ 

Overview of contents

Contents	
General	2
Product overview	3
Ordering code single pumps	4
Ordering code multiple pumps	5
Drive shafts	6
Front cover	6
Line ports	7
Pumps with integral valves	8
Design calculations for pumps	8
Performance charts	9
Noise charts	12
Specifications	14
Drive arrangements	15
Multiple pumps through drives	17
Unit dimensions	18
Fittings	23
Service parts	24
Notes on commissioning and maintenance	25
Ordering-No.	26

Features

- Nominal pressure 280 bar
- Slide bearings for heavy duty applications
- Drive shafts to ISO or SAE
- Combination of several pumps possible
- Line ports: connection flanges
- Consistent high quality thru mass production
- Numerous configuration variants available
- Cast case available on request

General

Rexroth external gear pumps are available as standard gear pumps in the 4 series of B, F, N and G, and as Silence gear pumps, in which the displacements are graded by different gear widths. Further configuration variants are given by different flanges, shafts, valve arrangements and multiple pump combinations.

Construction

The external gear unit consists essentially of a pair of gears supported in bearing bushings or bearing, dependent on the series, and the case with a front and rear cover. The drive shaft protrudes from the front cover where it is sealed by the shaft seal ring. The bearing forces are absorbed by special slide bearings with sufficient elasticity to produce surface contact instead of line contact. They also ensure excellent resistance to galling – especially at low speed. The gears have 12 teeth. This keeps both flow pulsation and noise emission to a minimum.

The internal sealing is achieved by forces which are proportional to delivery pressure. This ensures optimum efficiency. This ensures optimum efficiency. The sealing zone between the gear teeth and the bearings is controlled by the admission of operating pressure to the rear of the bearing bushings. Special seals form the boundary of the zone. The radial clearance at the tips of the gear teeth is sealed by internal forces pushing them against the case.

Axial and radial compensation for gear pump

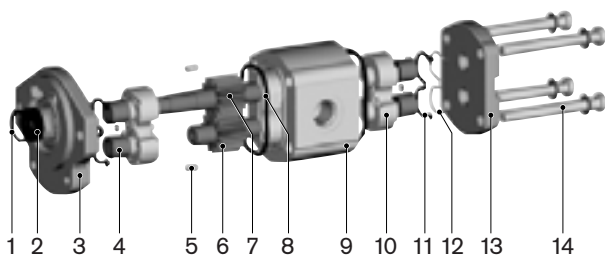
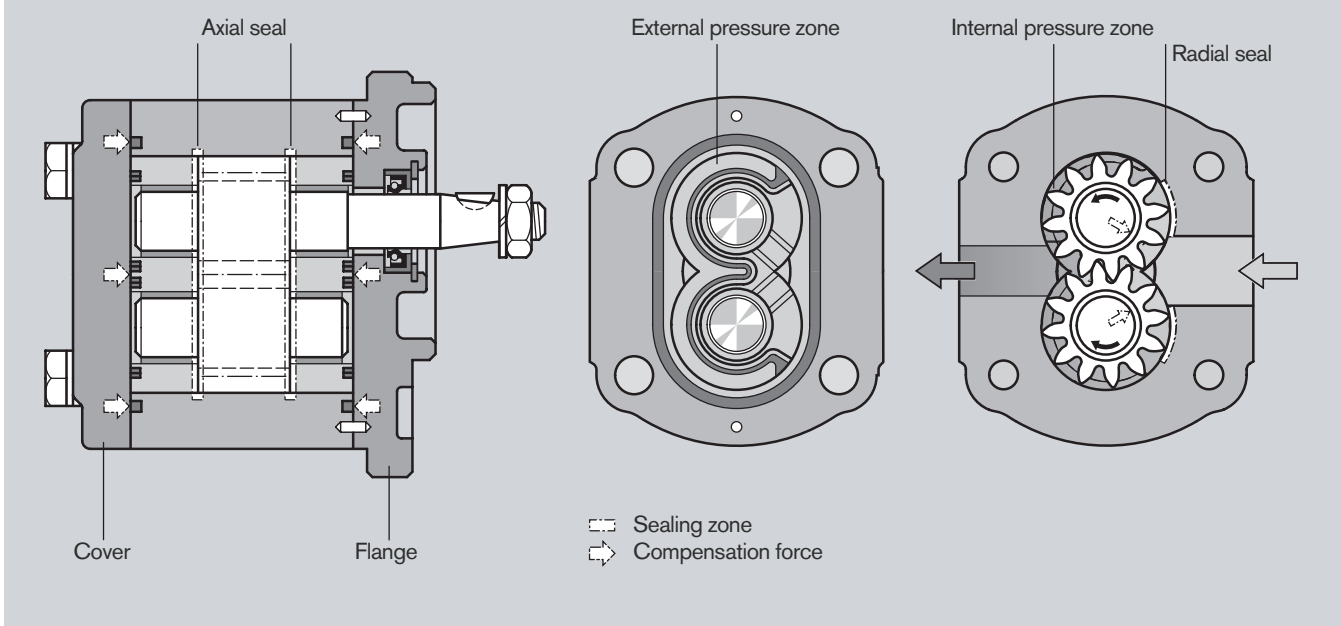

- | | |
|---------------------|--------------------|
| 1 Retaining ring | 8 Case seal |
| 2 Shaft seal ring | 9 Pump case |
| 3 Front cover | 10 Bearing |
| 4 Slide bearing | 11 Axial zone seal |
| 5 Centering pin | 12 Support |
| 6 Gear | 13 End cover |
| 7 Gear (frictional) | 14 Fixing screws |

Overview of "Series G" standard types

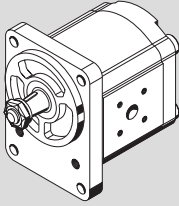
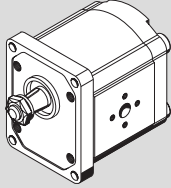
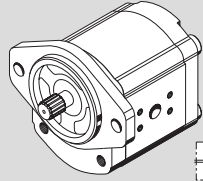
Version	Page	Version	Page	Version	Page
	18		19		20 21 22

The AZ configurator at www.boschrexroth.com/azconfigurator

The AZ configurator assists you to configure your individual external gear unit easily and user-friendly. You only need to specify your requirements: From the displacement, direction of rotation, drive shaft, connection flange right up to the required rear cover. You immediately receive a project drawing (PDF format) if a configuration already exists. You receive the price of the configured external gear unit upon request.



The AZ configurator assists you to configure your individual external gear unit easily and user-friendly – all data needed for project planning are acquired thru menu guidance.





























Selection is made either on an ordering code or your technical requirements. This means that you can search for external gear units that have already been configured, or you specify the configuration variant of the external gear unit based upon the operating parameters you require.



If the external gear unit you selected has been released you will receive the part number, ordering code and a detailed installation drawing. If your special configuration is not available please send your specification to Rexroth. One of our employees will then contact you.

Ordering code

External gear units Single pumps Standard

AZ	P	G	-	2	2	-	063	R	C	B	20	M	B	18009	S xxxx																														
<table border="1"> <tr> <td>Function</td> <td rowspan="3">Special design *)</td> </tr> <tr> <td>P = Pump</td> </tr> <tr> <td>Series</td> </tr> <tr> <td>2 = 2nd generation</td> <td rowspan="4"> Valve adjustment 200 xx = PRV 200 bar xxx 11 = FCV 11 l/min 18009 = PRV + FCV 180 bar, 9 l/min </td> </tr> <tr> <td>Version</td> </tr> <tr> <td>1 = Phosphatized, pinned</td> </tr> <tr> <td>2 = corrosion-resistant, pinned</td> </tr> <tr> <td>3 = Cast case (available on request)</td> <td rowspan="5"> Rear cover B = Standard D = PRV residual flow internal E = FCV residual flow external S = FCV residual flow internal V = PRV + FCV </td> </tr> <tr> <td>Size G</td> </tr> <tr> <td>022 = 22.5 cm³/rev</td> </tr> <tr> <td>025 = 25.0 cm³/rev</td> </tr> <tr> <td>028 = 28.0 cm³/rev</td> </tr> <tr> <td>032 = 32.0 cm³/rev</td> <td rowspan="6"> Seals M = NBR P = FPM K = NBR, SSR in FPM </td> </tr> <tr> <td>036 = 36.0 cm³/rev</td> </tr> <tr> <td>040 = 40.0 cm³/rev</td> </tr> <tr> <td>045 = 45.0 cm³/rev</td> </tr> <tr> <td>050 = 50.0 cm³/rev</td> </tr> <tr> <td>056 = 56.0 cm³/rev</td> </tr> <tr> <td>063 = 63.0 cm³/rev</td> <td rowspan="2"> Direction of rotation R = Clockwise L = Counterclockwise </td> </tr> <tr> <td>*) Some of the special designs shown on pages 18–22 are not covered in the illustration of the ordering code.</td> </tr> </table>														Function	Special design *)	P = Pump	Series	2 = 2nd generation	Valve adjustment 200 xx = PRV 200 bar xxx 11 = FCV 11 l/min 18009 = PRV + FCV 180 bar, 9 l/min	Version	1 = Phosphatized, pinned	2 = corrosion-resistant, pinned	3 = Cast case (available on request)	Rear cover B = Standard D = PRV residual flow internal E = FCV residual flow external S = FCV residual flow internal V = PRV + FCV	Size G	022 = 22.5 cm³/rev	025 = 25.0 cm³/rev	028 = 28.0 cm³/rev	032 = 32.0 cm³/rev	Seals M = NBR P = FPM K = NBR, SSR in FPM	036 = 36.0 cm³/rev	040 = 40.0 cm³/rev	045 = 45.0 cm³/rev	050 = 50.0 cm³/rev	056 = 56.0 cm³/rev	063 = 63.0 cm³/rev	Direction of rotation R = Clockwise L = Counterclockwise	*) Some of the special designs shown on pages 18–22 are not covered in the illustration of the ordering code.							
Function	Special design *)																																												
P = Pump																																													
Series																																													
2 = 2nd generation	Valve adjustment 200 xx = PRV 200 bar xxx 11 = FCV 11 l/min 18009 = PRV + FCV 180 bar, 9 l/min																																												
Version																																													
1 = Phosphatized, pinned																																													
2 = corrosion-resistant, pinned																																													
3 = Cast case (available on request)	Rear cover B = Standard D = PRV residual flow internal E = FCV residual flow external S = FCV residual flow internal V = PRV + FCV																																												
Size G																																													
022 = 22.5 cm³/rev																																													
025 = 25.0 cm³/rev																																													
028 = 28.0 cm³/rev																																													
032 = 32.0 cm³/rev	Seals M = NBR P = FPM K = NBR, SSR in FPM																																												
036 = 36.0 cm³/rev																																													
040 = 40.0 cm³/rev																																													
045 = 45.0 cm³/rev																																													
050 = 50.0 cm³/rev																																													
056 = 56.0 cm³/rev																																													
063 = 63.0 cm³/rev	Direction of rotation R = Clockwise L = Counterclockwise																																												
*) Some of the special designs shown on pages 18–22 are not covered in the illustration of the ordering code.																																													
Drive shafts							Front cover				Line ports																																		
Suitable front cover <table border="1"> <tr> <td>C</td> <td>Tapered key shaft 1 : 5</td> <td></td> <td>B</td> </tr> <tr> <td>H</td> <td>Tapered key shaft 1 : 8</td> <td></td> <td>O</td> </tr> <tr> <td>D</td> <td>Splined shaft SAE J 744 22-4 13T</td> <td></td> <td>C</td> </tr> </table>							C	Tapered key shaft 1 : 5		B	H	Tapered key shaft 1 : 8		O	D	Splined shaft SAE J 744 22-4 13T		C	<table border="1"> <tr> <td>B</td> <td>Rectangular flange Centering Ø 105 mm</td> <td></td> </tr> <tr> <td>C</td> <td>SAE J 744 101-2 B 2-bolt flange Ø 101.6 mm</td> <td></td> </tr> <tr> <td>O</td> <td>Rectangular flange Centering Ø 50.78 mm</td> <td></td> </tr> </table>				B	Rectangular flange Centering Ø 105 mm		C	SAE J 744 101-2 B 2-bolt flange Ø 101.6 mm		O	Rectangular flange Centering Ø 50.78 mm		<table border="1"> <tr> <td>07</td> <td>Square flange SAE thread, metric</td> <td></td> </tr> <tr> <td>20</td> <td>Rectangular Flange</td> <td></td> </tr> <tr> <td>30</td> <td>Rectangular Flange</td> <td></td> </tr> </table>					07	Square flange SAE thread, metric		20	Rectangular Flange		30	Rectangular Flange	
C	Tapered key shaft 1 : 5		B																																										
H	Tapered key shaft 1 : 8		O																																										
D	Splined shaft SAE J 744 22-4 13T		C																																										
B	Rectangular flange Centering Ø 105 mm																																												
C	SAE J 744 101-2 B 2-bolt flange Ø 101.6 mm																																												
O	Rectangular flange Centering Ø 50.78 mm																																												
07	Square flange SAE thread, metric																																												
20	Rectangular Flange																																												
30	Rectangular Flange																																												



























Not all variants can be selected by using ordering code!

Please select the required pump by using the selection tables (standard types) or after consultation with Bosch Rexroth!

Special options are possible upon request.

Ordering code

External gear units, Multiple pumps, Standard

AZ	P	GGFF	-	x	x	-	032/022/016/005	R	C	B	20	20	20	20	K	B				
Function P = Pump Series B = 1.0...7.1 cm ³ /rev S = 4.0...28 cm ³ /rev F = 4.0...28 cm ³ /rev T = 20.0...36 cm ³ /rev N = 20.0...36 cm ³ /rev U = 22.5...63 cm ³ /rev G = 22.5...63 cm ³ /rev Series , relates to pump section 1 2 = 2nd generation Version , relates to pump section 1 2 = corrosion-resistant, pinned Size as per individual Series Direction of rotation R = Clockwise L = Counterclockwise							Rear cover relates to last pump part B = Standard Seals M = NBR P = FPM K = NBR, WDR in FPM WDR relates to pump part 1													
Drive shafts relates to pump part 1 Series B: H Tapered key shaft 1 : 5  O Suitable front cover							Front cover relates to pump part 1 O Square flange Centering Ø 25.38 mm 							Line port every pump parts 01 Pipe thread ISO 228/1  20 Rectangular Flange 						
Series F, S: C Tapered key shaft 1 : 5  B H Tapered key shaft 1 : 8  O R Splined shaft SAE J 744 16-4 9T  R							B Square flange Centering Ø 80 mm  O Square flange Centering Ø 36.47 mm SAE J 744 82-2 A  R 2-bolt flange Ø 82.55 mm 							20 Rectangular Flange  30 Rectangular Flange 						
Series N, T: C Tapered key shaft 1 : 5  B D Splined shaft SAE J 744 22-4 13T  C							B Square flange Centering Ø 100 mm  C SAE J 744 101-2 B 2-bolt flange Centering Ø 101.6 mm 							07 Square flange SAE Thread, metric  20 Rectangular Flange 						
Series G, U: C Tapered key shaft 1 : 5  B D Splined shaft SAE J 744 22-4 13T  C H Tapered key shaft 1 : 8  O							B Square flange Centering Ø 105 mm  C SAE J 744 101-2 B 2-bolt flange Centering Ø 101.6 mm  O Square flange Centering Ø 50.78 mm 							07 Square flange SAE Thread, metric  20 Rectangular Flange  30 Rectangular Flange 						

Not all variants can be selected by using ordering code!

Please select the required pump by using the selection tables (standard types) or after consultation with Bosch Rexroth!

Special options are possible upon request.

Drive shafts

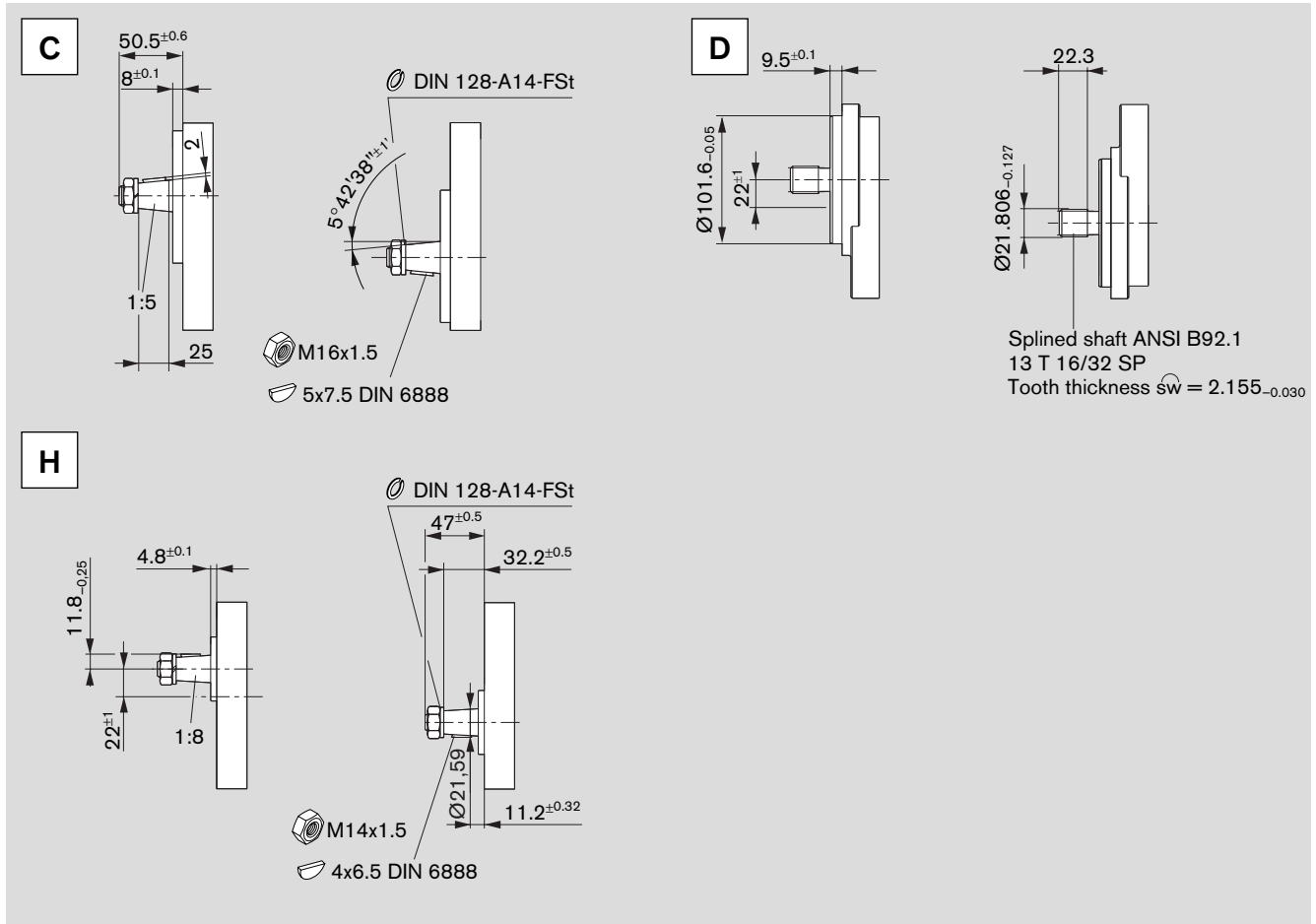

Front cover

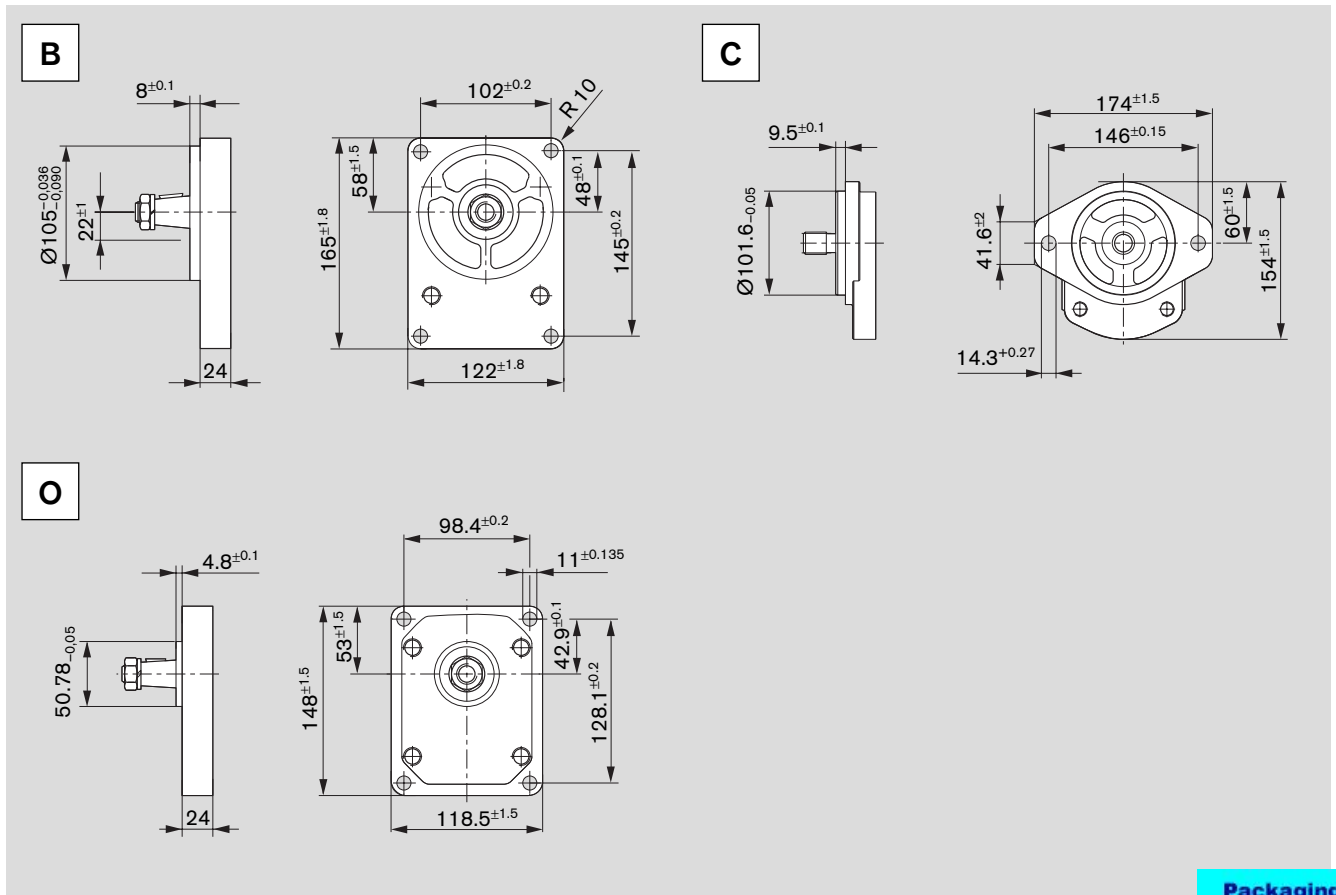

Line port

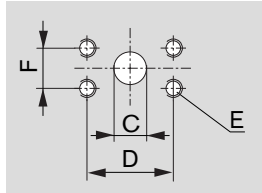

07 Square flange SAE, thread, metric

Ordering code	Size	Delivery side				Suction side			
		C	D	E	F	C	D	E	F
07	22.5...28 cm ³	18	47.6	M 10 depth 18	22.2	25	52.4	M 10 depth 14	26.2
	32.0...50 cm ³	25	52.4		26.2	32	58.7		30.2
	56.0...63 cm ³	32	58.7		30.2	38	69.8		35.8

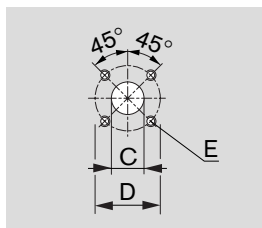

20 Rectangular flange

Ordering code	Size	Delivery side			Suction side		
		C	D	E	C	D	E
20	22.5...63 cm ³	18	55	M 8 depth 13	26	55	M 8 depth 13

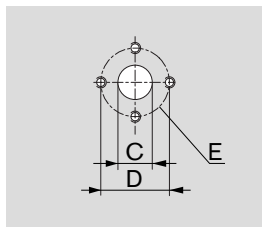

30 Rectangular flange

Ordering code	Size	Delivery side			Suction side		
		C	D	E	C	D	E
30	22.5...56 cm ³	18	39.7	M 8 depth 13	26	50.8	M 10 depth 13
30	63 cm ³	26	50.8	M 10 depth 13	36	62	M 10 depth 13

Gear pumps with integral valves

In order to reduce external pipework it is possible to incorporate a flow-control valve or pressure-relief valve in the cover of the gear pump. A typical application of this is in the supply of hydraulic oil in power steering systems. The pump delivers a constant flow irrespective of the speed at which it is driven. The excess flow is either returned internally to the suction port or distributed externally to other items of equipment.

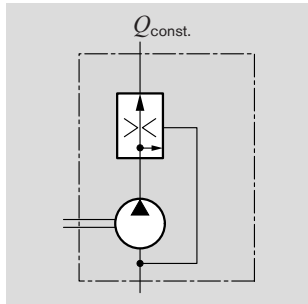
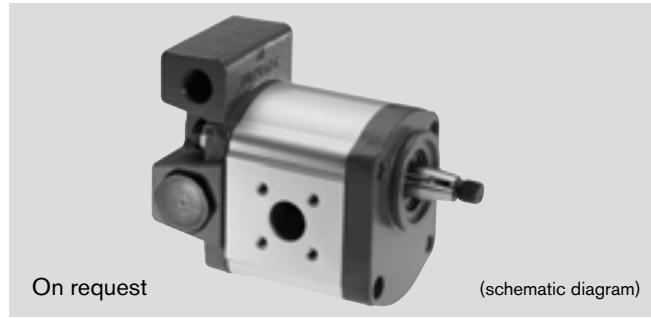

3-way flow-control valve.
Excess flow returned to suction line
 $Q_{const.} = 2...30 \text{ l/min}$

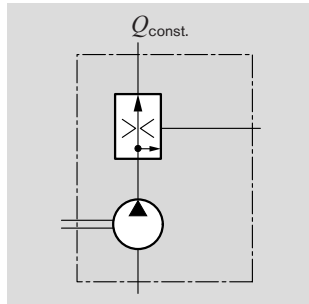

3-way flow-control valve.
Excess flow distributed externally; loadable
 $Q_{const.} = 2...30 \text{ l/min}$

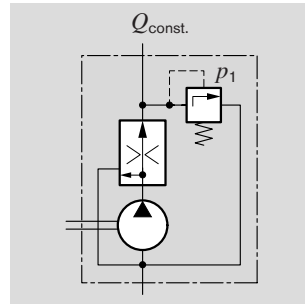

3-way flow-control valve with pressure-relief valve.
Excess flow returned to suction line
 $Q_{const.} = 2...30 \text{ l/min}$
 $p_1 = 100...180 \text{ bar}$

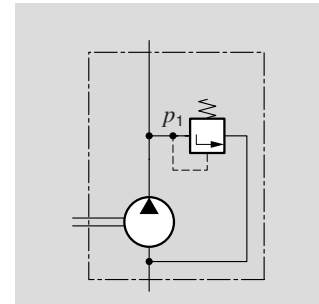

Pressure-relief valve.
Discharge returned to suction line
 $p_1 = 5...250 \text{ bar}$

Ordering code

S	xxx17
---	-------

E	xxx12
---	-------

V	15011
---	-------

D	180xx
---	-------

Design calculations for pumps

The design calculations for pumps are based on the following parameters:

- V [cm^3/rev] Displacement
- Q [l/min] Delivery
- p [bar] Pressure
- M [Nm] Drive torque
- n [rev/min] Drive speed
- P [kW] Drive power

It is also necessary to allow for different efficiencies such as:

- η_v Volumetric efficiency
- η_{hm} Hydraulic-mechanical efficiency
- η_t Overall efficiency

The following formulas describe the various relationships.

They include correction factors for adapting the parameters to the usual units encountered in practice.

Caution: Diagrams providing approximate selection data will be found on subsequent pages.

$$Q = V \cdot n \cdot \eta_v \cdot 10^{-5}$$

$$p = \frac{M \cdot \eta_{hm}}{1.59 \cdot V}$$

$$P = \frac{p \cdot Q}{6 \cdot \eta_t}$$

$$V = \frac{Q}{n \cdot \eta_v} \cdot 10^5$$

$$V = \frac{M \cdot \eta_{hm}}{159 \cdot p}$$

$$Q = \frac{6 \cdot P \cdot \eta_t}{p}$$

$$n = \frac{Q}{V \cdot \eta_v} \cdot 10^5$$

$$M = \frac{1.59 \cdot V \cdot p}{\eta_{hm}}$$

$$p = \frac{6 \cdot P \cdot \eta_t}{Q}$$

[%]

n — η_v — Q V [cm^3/rev] Q [l/min] p [bar]

M — η_{hm} — p

P — η_t — $p \cdot Q$ n [rev/min] P [kW] M [Nm]

Caution: η [%] e.g. 95 [%]

Performance charts

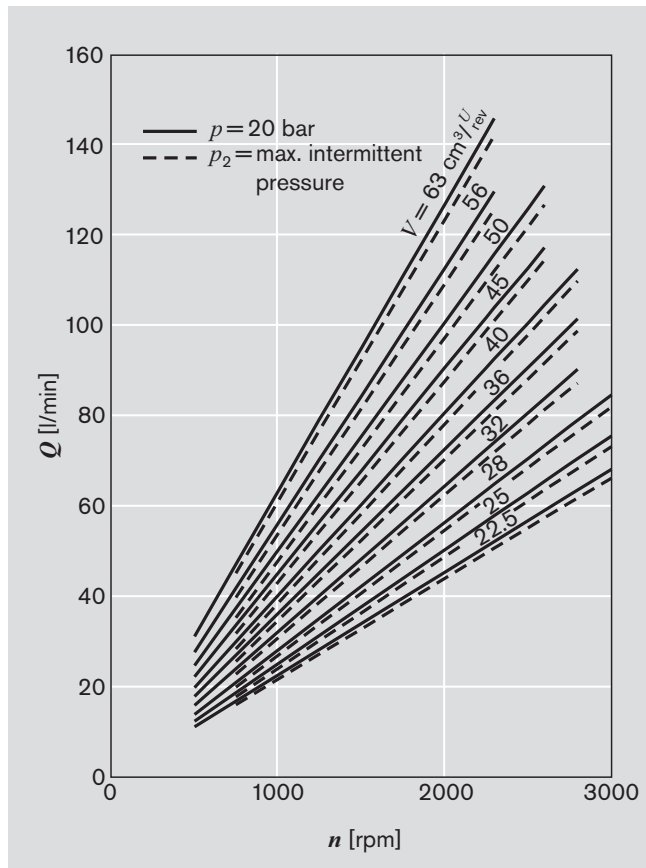

$\nu = 35 \text{ mm}^2/\text{s}, \vartheta = 50^\circ\text{C}$

$Q = f(n, V)$ incl. η_v
 $P = f(n, p)$ ——— incl. η_t
 $M = f(n, p)$ - - - incl. η_{hm}

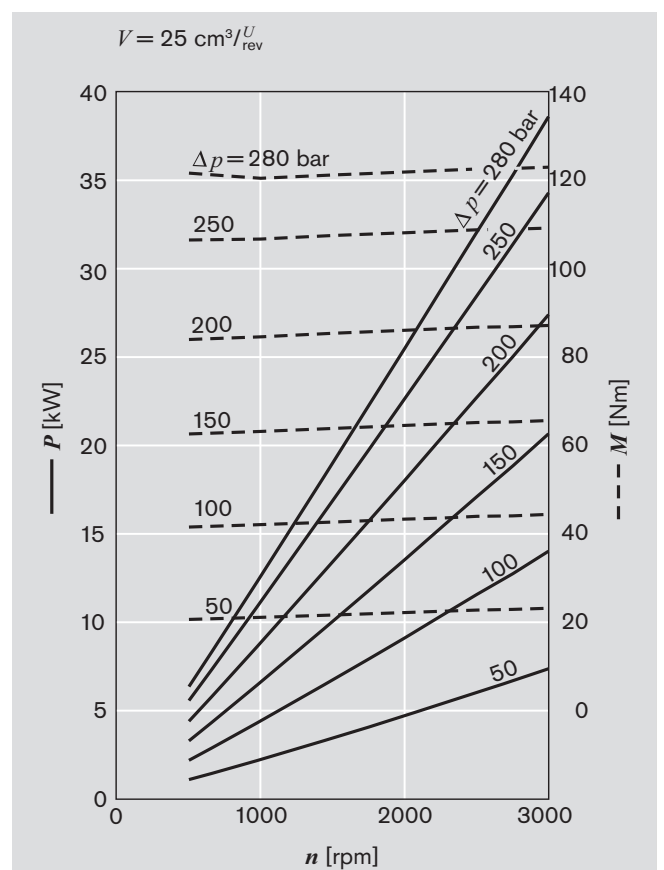
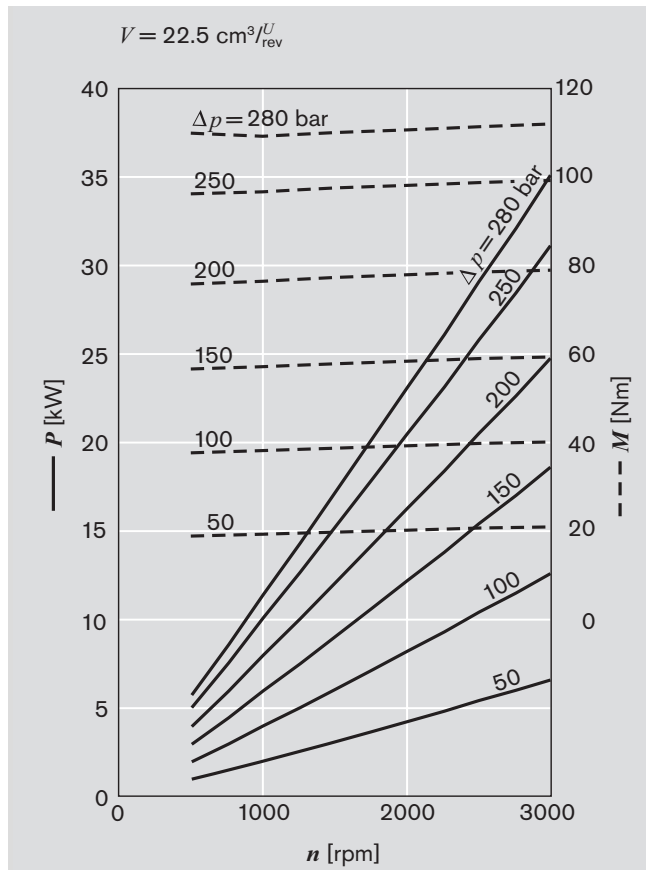

Performance charts (continued)

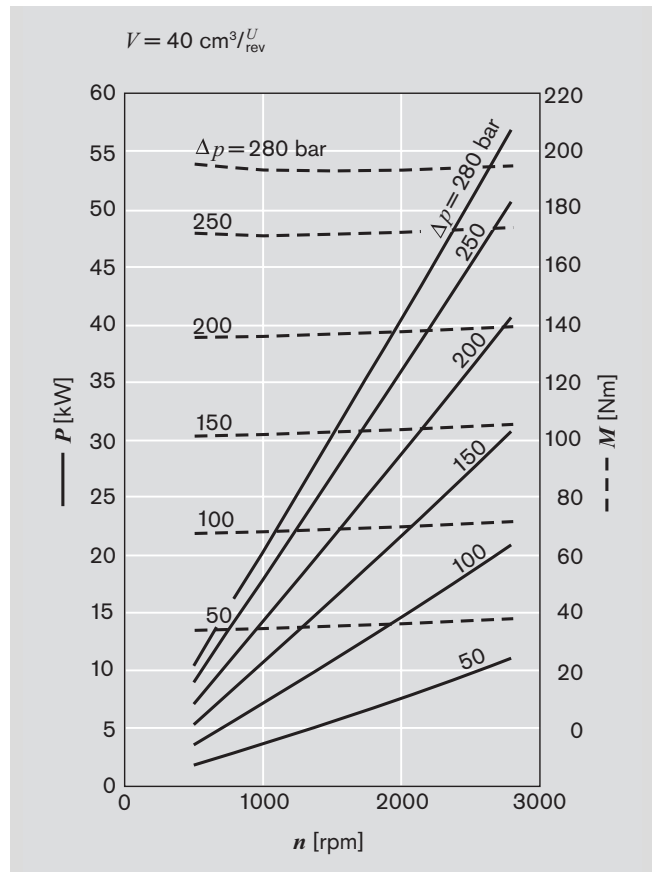
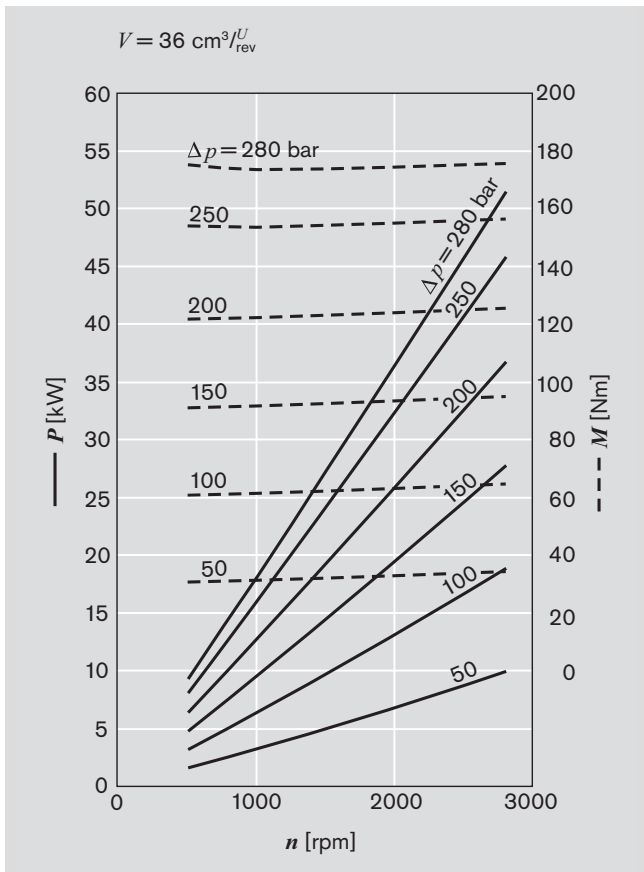
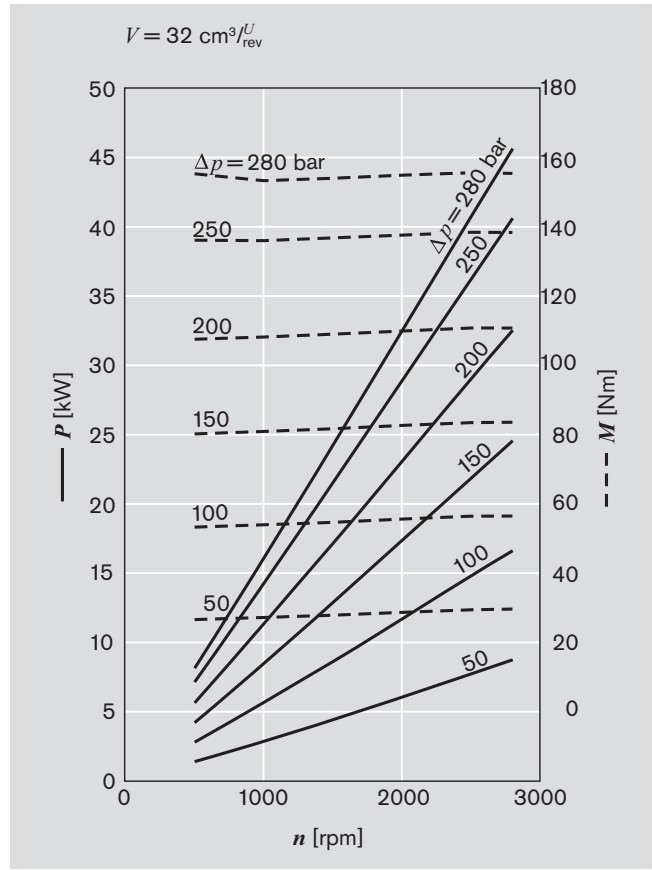
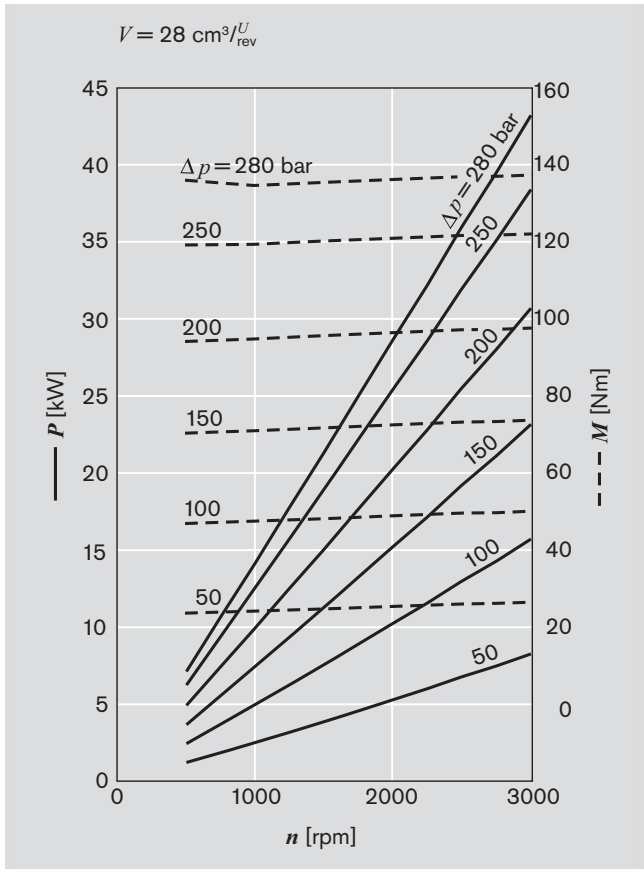

Performance charts (continued)

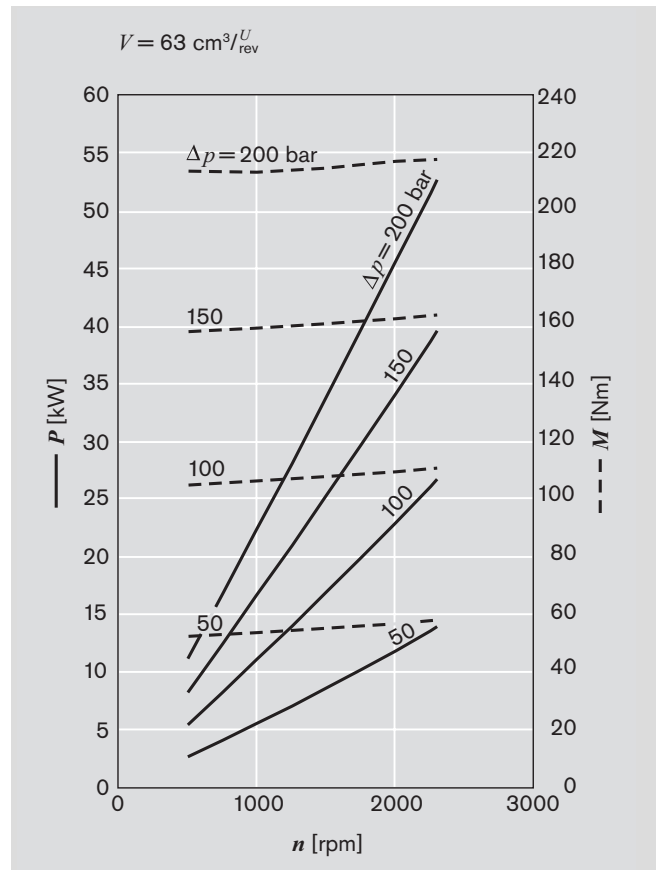
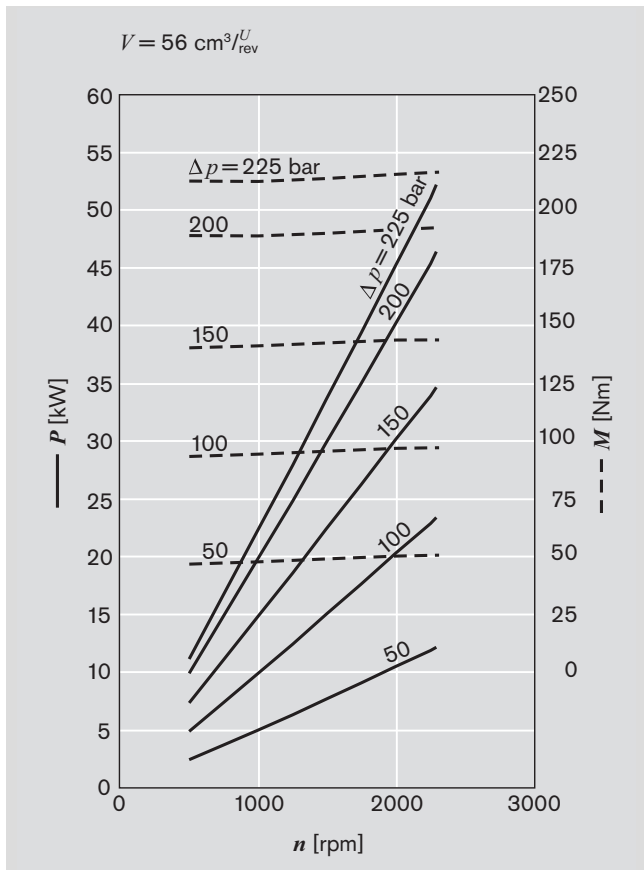
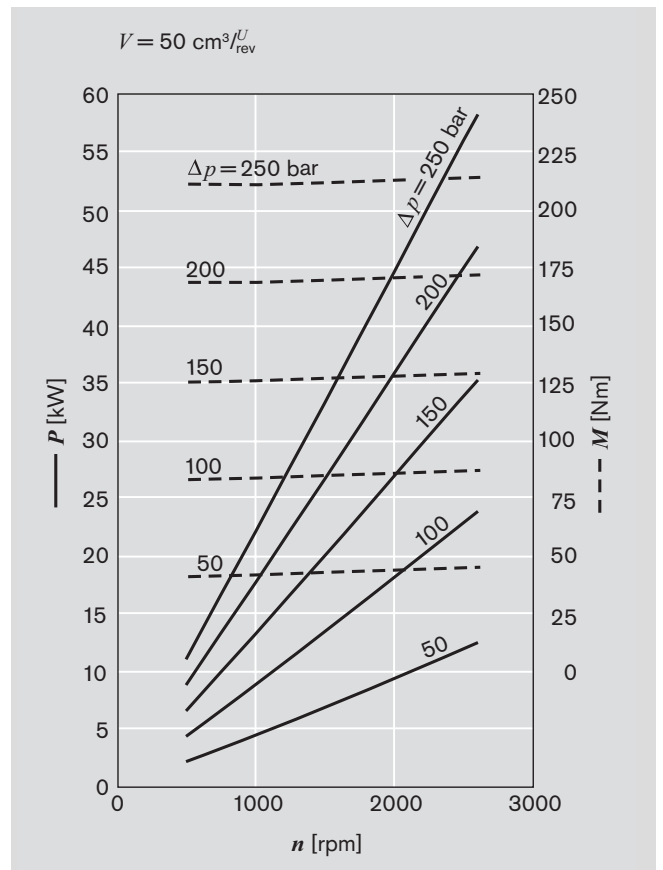
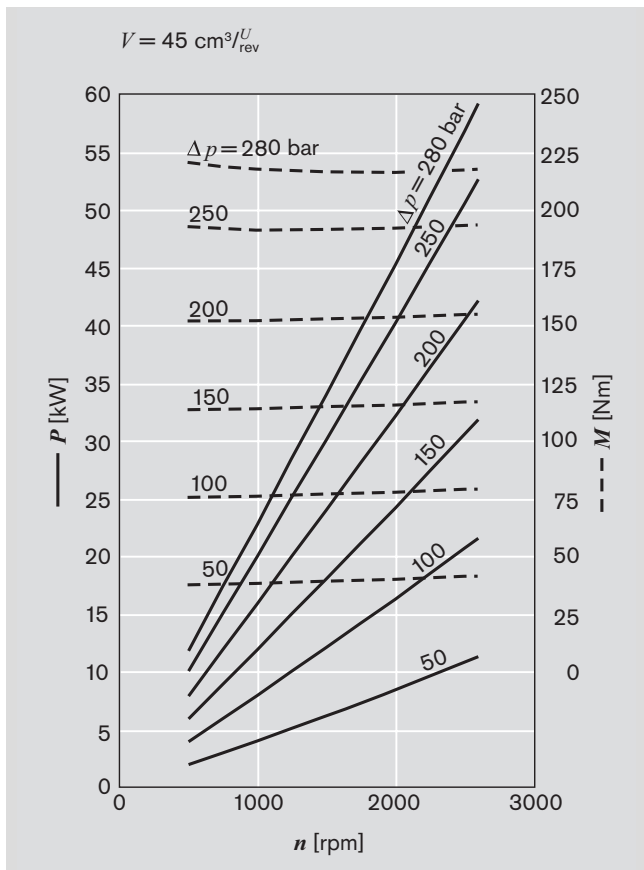

Noise charts

Noise level dependent on rotational speed, pressure range between 10 bar and pressure value p_2 (see page 14 Specifications table).

Oil data: $\nu = 32 \text{ mm}^2/\text{s}$, $\vartheta = 50^\circ\text{C}$.

Sound pressure level calculated from noise measurements made in the sound absorbent measuring room compliant with DIN 45 635, Part 26.

Spacing between measuring sensor – pump: 1 m.

These are typical characteristic values for the respective model. They describe the airborne sound emitted solely by the pump. Environmental influences (installation site, piping, further system components) are not taken into consideration. Each value applies for a single pump.

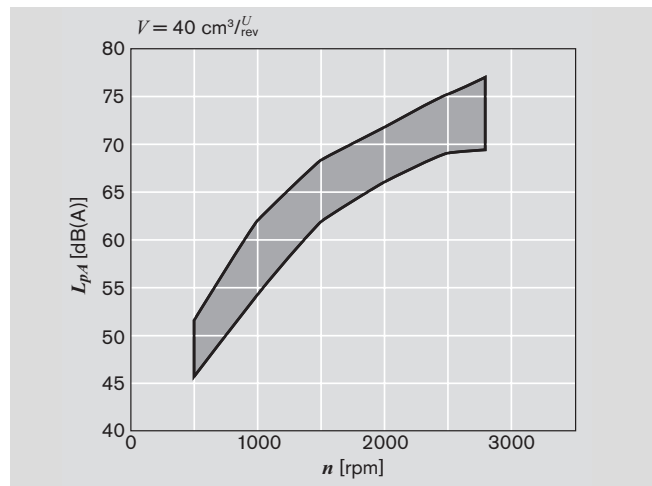
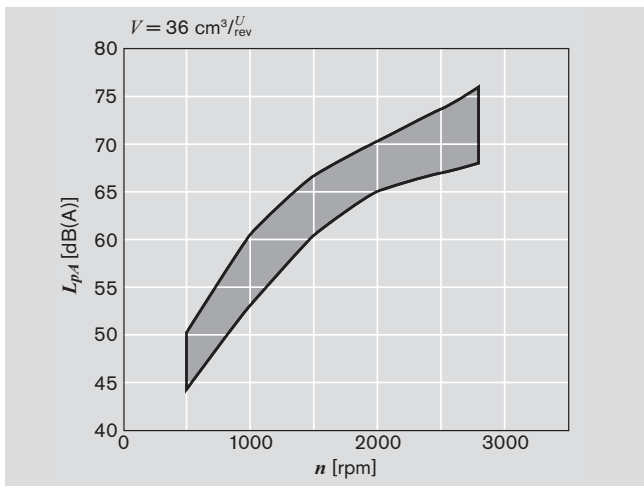
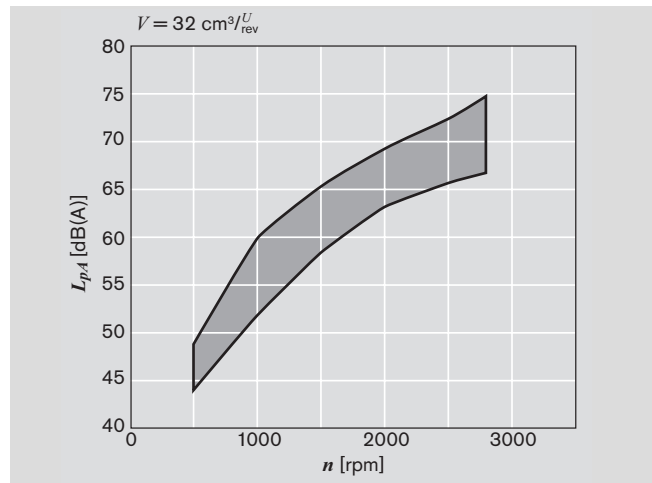
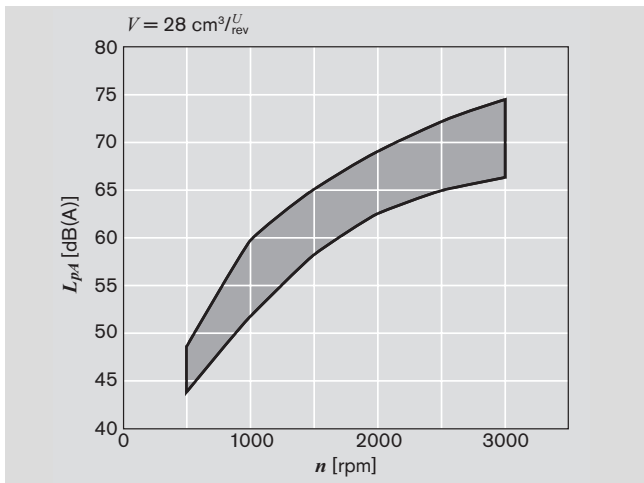
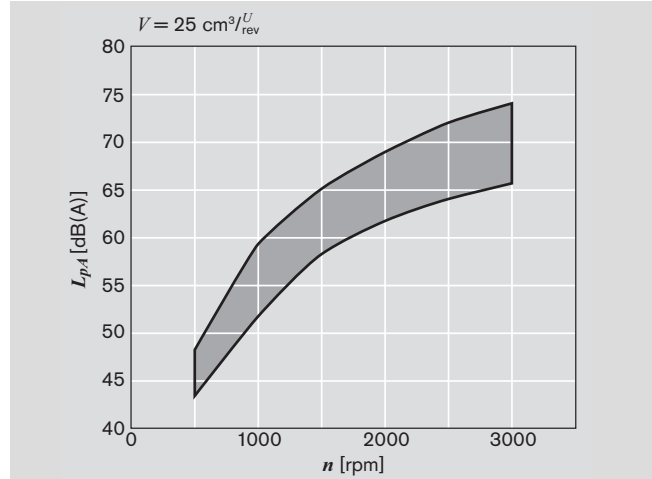
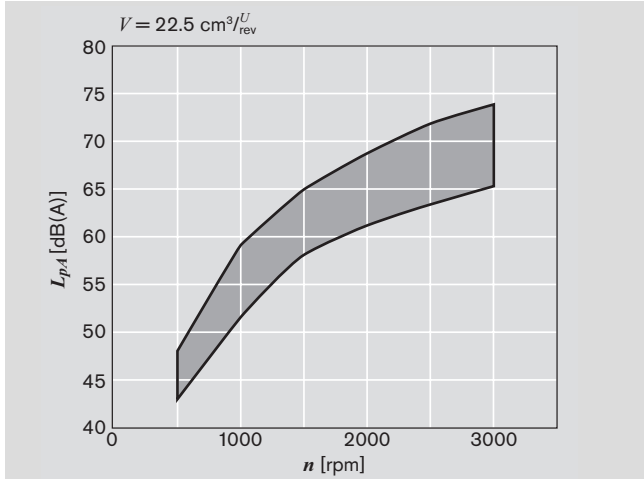

Noise charts (continued)

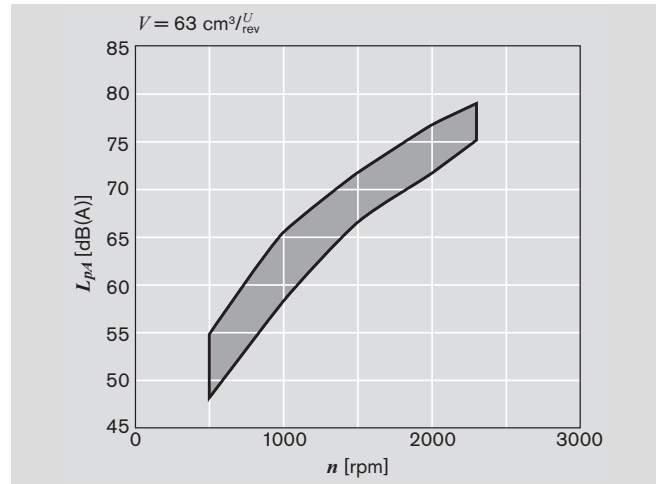
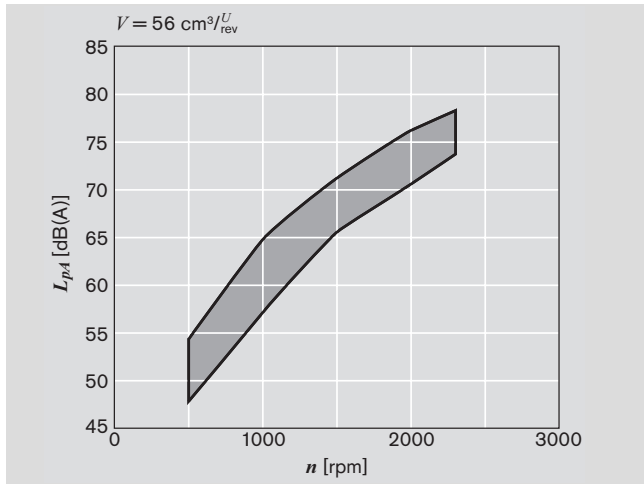
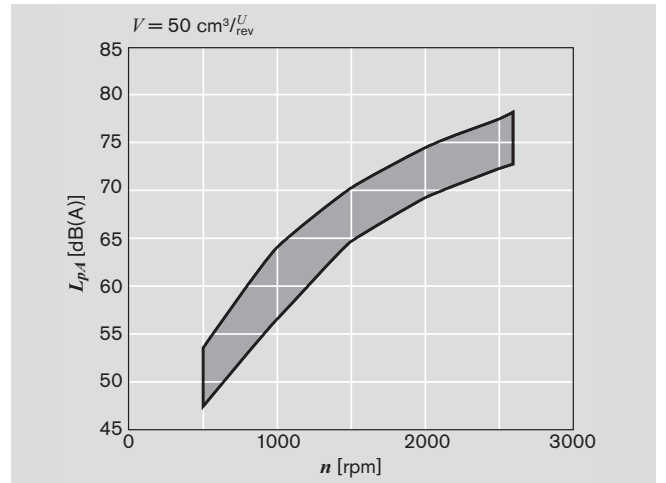
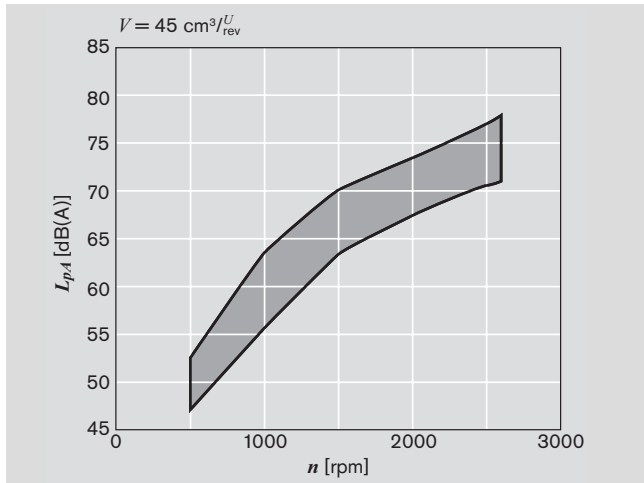

Characteristics

General	
Construction	External gear pump
Mounting	Flange or through-bolting with spigot
Line port	Flange
Direction of rotation (looking on shaft)	Clockwise or counterclockwise, the pump may only be driven in the direction indicated
Installation position	Any
Load on shaft	Radial and axial forces after consulting
Ambient temperature range	-30°C...+80°C with NBR seal -20°C...+110°C with FPM seal
Hydraulic fluid	- Mineral oil compliant with DIN 51 524, 1-3, however under higher load at least HLP compliant with DIN 51 524 Part 2 recommended. - Comply with RE 07075 - Further operating fluids possible after consultation
Viscosity	12...800 mm ² /s permissible range 20...100 mm ² /s recommended range ...2.000 mm ² /s permissible range for start up
Temperature of hydraulic fluid	-30°C...+80°C -20°C...+110°C with FPM seal
Filtration *)	At least cleanliness level 21/18/15 compliant with ISO 4406 (1999)

*) During the application of control systems or devices with critical counter-reaction, such as steering and counter-balance valves, the type of filtration selected must be adapted to the sensitivity of these devices/systems.

Safety requirements pertaining to the whole systems are to be observed.

In the case of applications with high numbers of load cycles please consulting.

Definition of direction of rotation

Always look on the drive shaft.

Caution: Dimensions drawings always show clockwise-rotation pumps. On counterclockwise-rotation pumps the positions of the drive shaft and the suction and pressure ports are different.

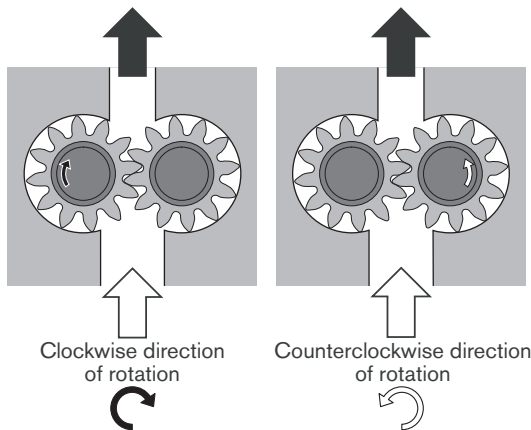

Definitions of pressures

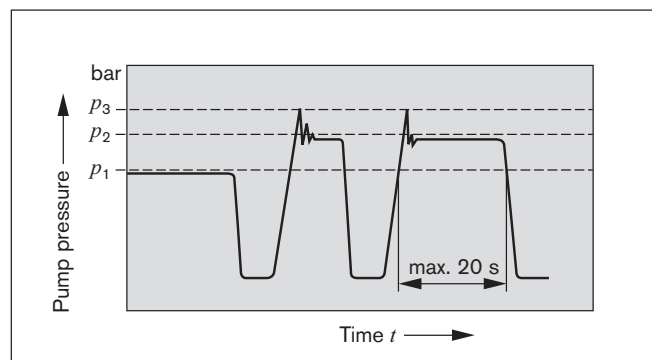

p_1 max. continuous pressure
 p_2 max. intermittent pressure
 p_3 max. peak pressure

Model AZPG

													Upon request			
Displacement	V	cm ³ /rev	22.5	25	28	32	36	40	45	50	56	63	70	80	100	
Suction pressure	p_e		0.7...3 (absolute), with tandem pumps: $p_e (p_2) = \max. 0.5 > p_e (p_1)$													
max. continuous pressure	p_1	bar	250								220	195	170	120	90	80
max. intermittent pressure	p_2		280								250	225	200	150	120	100
max. peak pressure	p_3		300								280	250	230	180	150	120
min.	< 100	rpm	500	500	500	500	500	500	500	500	500	500	500	500	500	
rpm at bar	12 mm ² /s	100...180	1200	1200	1000	1000	1000	800	800	800	800	800	800	800	800	
		180... p_2	1400	1400	1400	1400	1200	1200	1000	1000	1000	1000	1000	1000	1000	
	25 mm ² /s	p_2	600	600	500	500	500	500	500	500	500	500	500	600	800	
max. rpm at	p_2		3000	3000	3000	2800	2800	2800	2600	2600	2300	2300	2200	2000	1700	

Drive arrangement

1. Flexible couplings

The coupling must not transfer any radial or axial forces to the pump.

The maximum radial runout of shaft spigot is 0.2 mm.

Refer to the fitting instructions provided by the coupling manufacturer for details of the maximum permitted shaft misalignment.

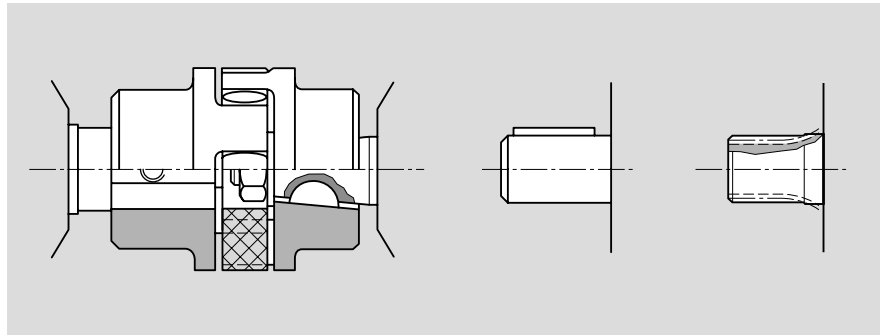

2. Coupling sleeve

Used on shafts with DIN or SAE splining. Caution: There must be no radial or axial forces exerted on the pump shaft or coupling sleeve. The coupling sleeve must be free to move axially. The distance between the pump shaft and drive shaft must be $3.5^{+1.5}$. Oil-bath or oil-mist lubrications is necessary.

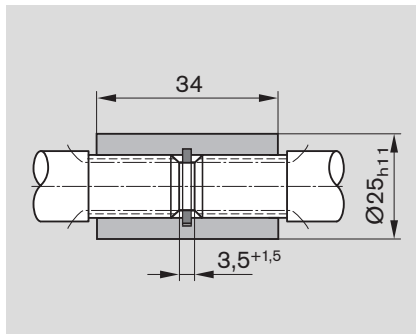

Splined shaft	Ordering code	M_{max} [Nm]
SAE-B 13 teeth	D	300
SAE-C 15 teeth	E	450

3. Drive shaft with tang

For the close-coupling of the pumps to electric motor or internal-combustion engine, gear, etc. The pump shaft has a special tang and driver (3) (not included in supply). There is no shaft sealing.

The recommended arrangements and dimensions for the drive end and sealing are as follows.

① Drive shaft

Case-hardening steel DIN 17 210
 e.g. 20 MnCrS 5
 case-hardened 1.0 deep; HRA 83 \pm 2
 Surface for sealing ring
 ground without rifling $R_t \leq 4\mu\text{m}$

② Radial shaft seal

with rubber covered seal
 (see DIN 3760, Type AS, or double-lipped ring).
 Cut 15° chamfer or fit shaft seal ring with protection sleeve.

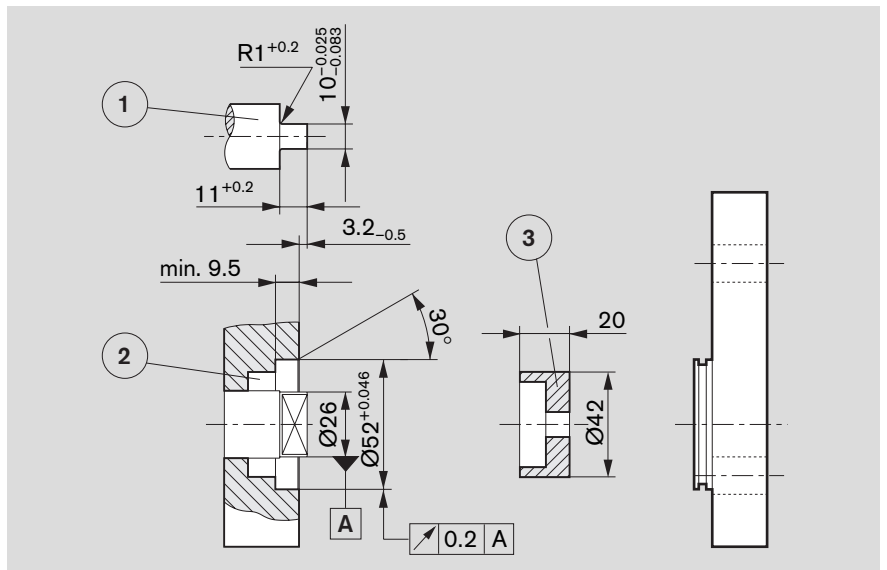

M_{max} [Nm]	V [cm ³ /rev]	p_{max} [bar]
130	28	270
	36	210
	40	190
	45	160
	50	150
	56	135
	63	120
	70	110
	80	95
100	75	

For drive shaft with tang

4 . Outboard bearing

Outboard bearing eliminate possible problems when the pumps are driven by V-belts or gearwheels. The diagrams below show the maximum radial and axial loads that can be tolerated based on a bearing life of $L_H = 1000$ h.

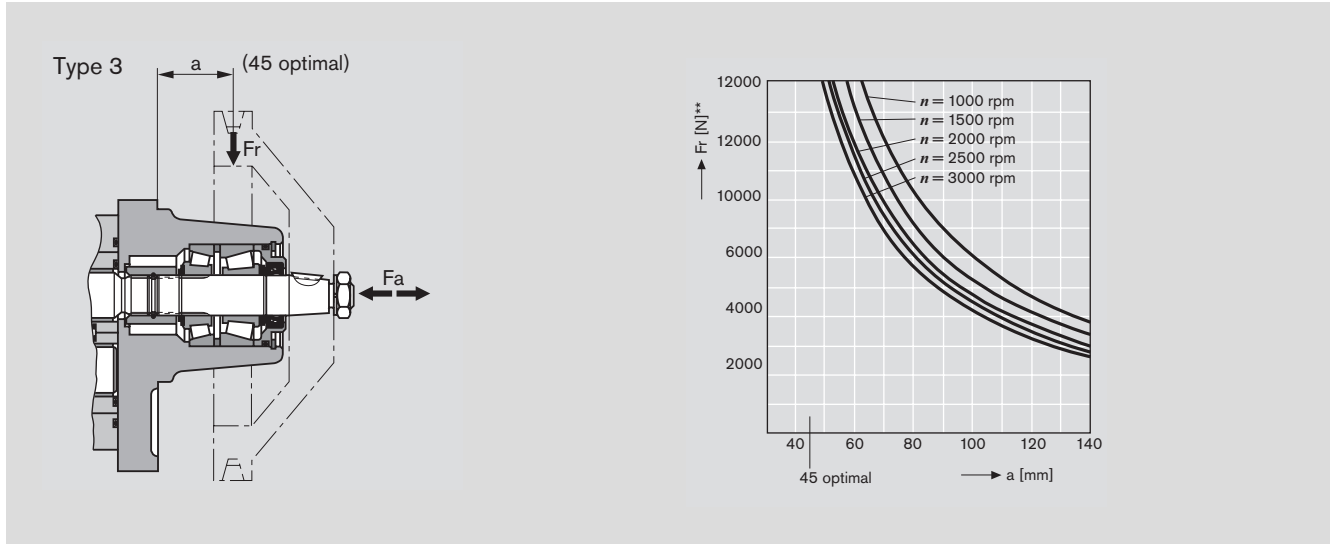

Multiple gear pumps

Gear pumps are well-suited to tandem combinations of pumps in which the drive shaft of the first pump is extended to drive a second pump and sometimes a third pump in the same manner. A coupling is fitted between each pair of pumps. In most cases each pump is isolated from its neighbor, i.e. the suction ports are separate from one another. A common suction port is also possible as an option.

Caution: Basically, the specifications for the single pumps apply, but with certain restrictions:

Max. speed: This is determined by the highest rated pump speed in use.

Pressures: These are restricted by the strength of the drive shaft, the through drives and the drivers. Appropriate data is given in the dimensional drawings.

Pressure restrictions during standard through drive

In the case of series G, the driver for the second pumping stage can carry a load of up to $M_{max.} = 95 \text{ Nm}$, i.e. there is a pressure restriction for the second stage and any further stages.

$M_{max.}$ [Nm]	V [cm ³ /rev]	p_{max} [bar]
65 Series F, S	16	230
	19	190
	22.5	160
	25	140
	28	130
130 Series G, U	22.5	280
	25	280
	28	260
	32	230
	36	200
	40	180
	45	160
	50	150
	56	130
	63	110

If the first stage is driven through a tang (driver) or outboard bearing type 1, pressure restrictions apply as indicated in the formula below.

Reinforced through drives are available for applications with higher transfer torques and/or rotational vibrations. Customized designs available on request.

Reinforced through drive

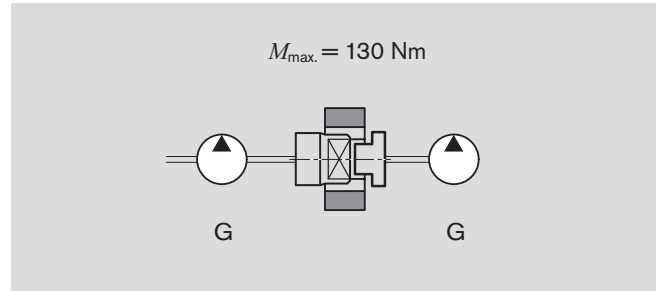
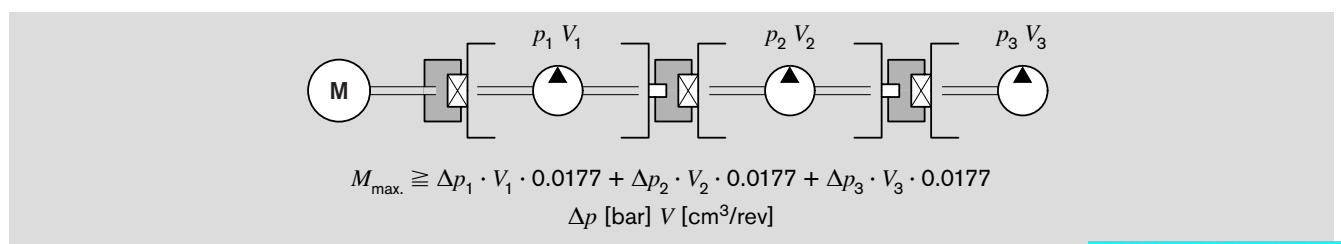
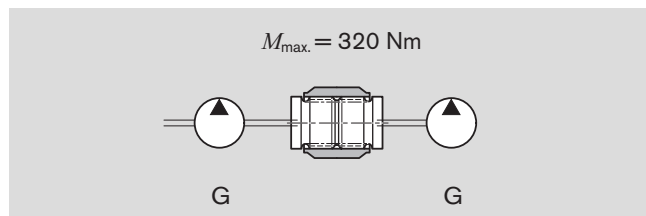

Combinations

Series pump 1	$M_{max.}$ [Nm]	Series pump 2
G	130	G
G	65	F
G	65	S

For configuration of multiple pumps we recommend the pump is positioned with the largest displacement on the drive side.

Max. transferrable drive torque

Function	Code letter	Designation	Max. transferrable drive torque* [Nm]
Splined shafts	D	SAE J744 22-4 (13T 16/32 DL)	300
	E	SAE-C 15 teeth	450
Tapered key shaft	C	1:5	290
	H	1:8	240

* These figures are valid providing the conditions defined on pages 15 and 16 are observed. Bosch Rexroth is to be consulted if the stated values are exceeded.

Unit dimensions

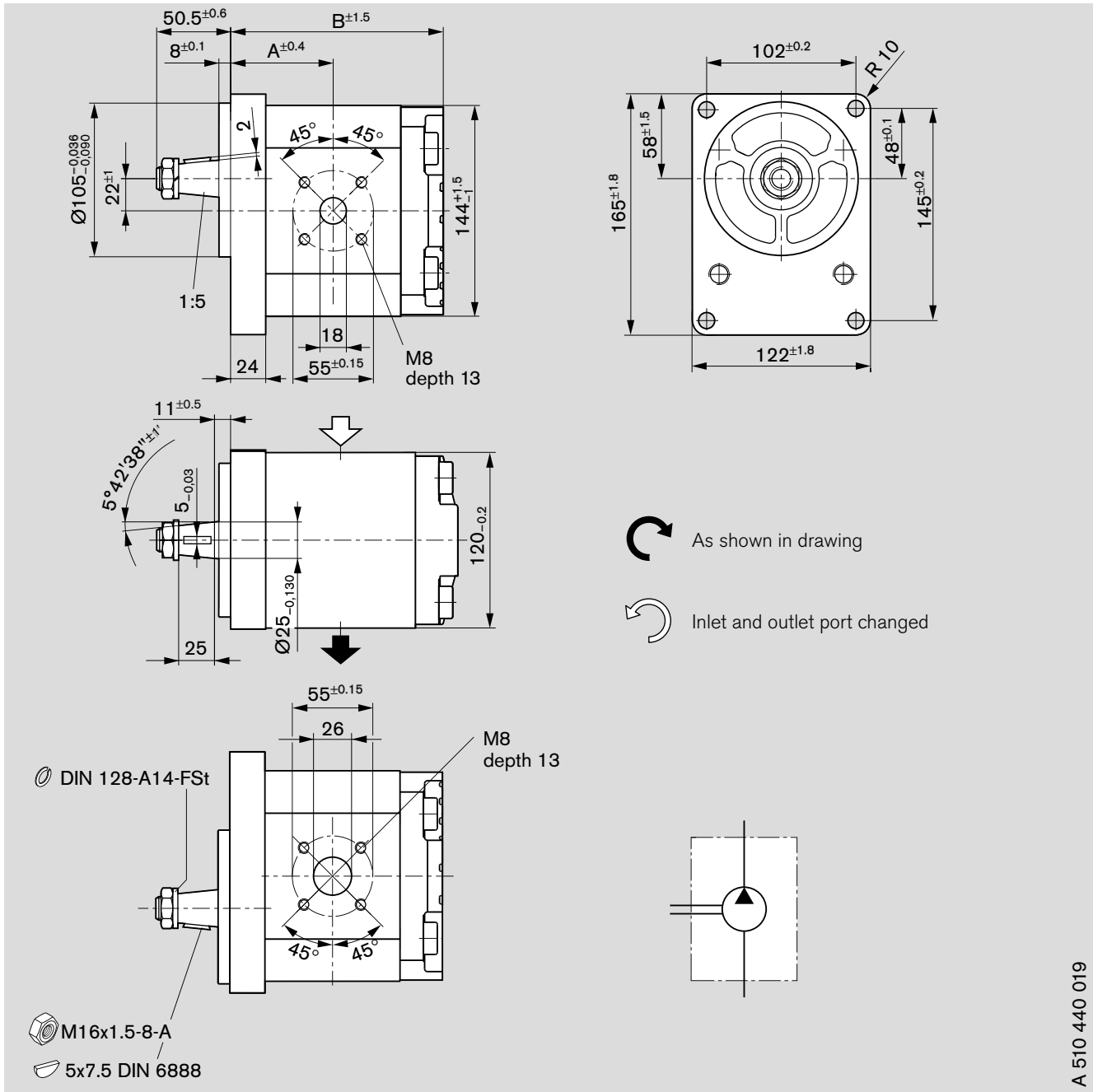

Standard range



A 510 440 019

Ordering code:

AZPG - 22 - C B 20 M B

Displacement [cm ³ /rev]	Ordering-No.		Max. operating pressure [bar]	Max. rotation speed [rpm]	kg	Dimension [mm]	
	 L	 R				A	B
22.5	0 510 725 441	0 510 725 164	280	3000	10.3	60.9	124.6
25	0 510 725 442	0 510 725 165	280	3000	10.4	61.9	126.6
28	0 510 725 443	0 510 725 166	280	3000	10.5	63.2	129.1
32	0 510 725 444	0 510 725 167	280	2800	10.7	64.8	132.4
36	0 510 725 445	0 510 725 168	280	2800	10.9	66.4	135.7
40	0 510 725 446	0 510 725 169	280	2800	11.0	68.1	139.0
45	0 510 725 447	0 510 725 170	280	2600	11.2	70.1	143.1
50	0 510 825 324	0 510 825 024	250	2600	11.4	72.2	147.2
56	0 510 825 325	0 510 825 025	225	2300	11.7	74.7	152.2
63	0 510 825 326	0 510 825 026	200	2300	12.0	77.6	158.0

Unit dimensions

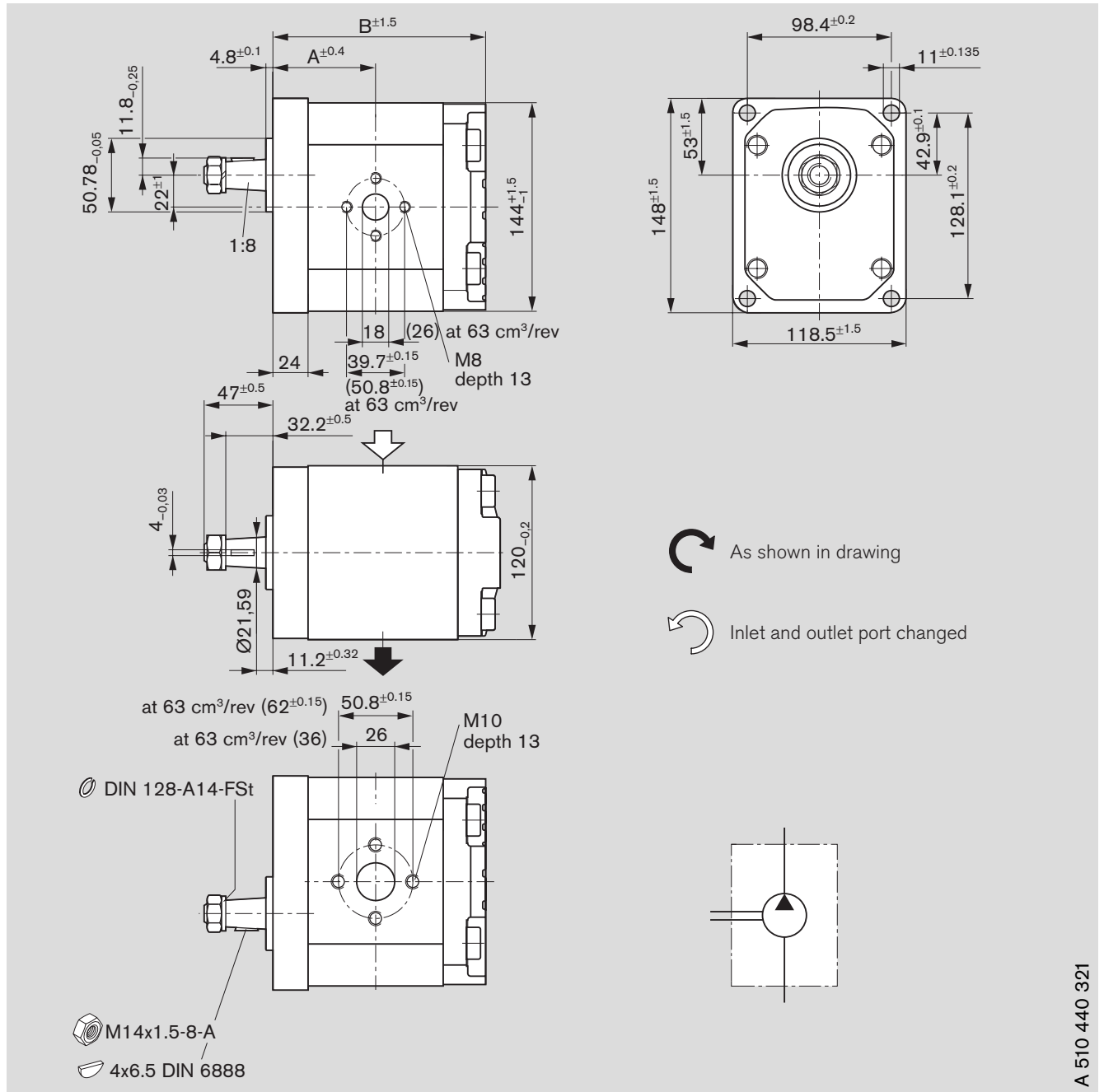

Standard range



A 510 440 321

Ordering code:

AZPG - 22 - H O 30 M B

Displacement [cm ³ /rev]	Ordering-No.		Max. operating pressure [bar]	Max. rotation speed [rpm]	kg	Dimension [mm]	
	 L	 R				A	B
22.5	0 510 725 448	0 510 725 171	280	3000	9.6	60.9	124.6
25	0 510 725 449	0 510 725 172	280	3000	9.7	61.9	126.6
28	0 510 725 450	0 510 725 173	280	3000	9.8	63.2	129.1
32	0 510 725 451	0 510 725 174	280	2800	10.0	64.8	132.4
36	0 510 725 452	0 510 725 175	280	2800	10.1	66.4	135.7
40	0 510 725 453	0 510 725 176	280	2800	10.3	68.1	139.0
45	0 510 725 454	0 510 725 177	280	2600	10.5	70.1	143.1
50	0 510 825 327	0 510 825 027	250	2600	10.7	72.2	147.2
56	0 510 825 328	0 510 825 028	225	2300	11.0	74.7	152.2
63	0 510 825 329	0 510 825 029	200	2300	11.2	77.6	158.0

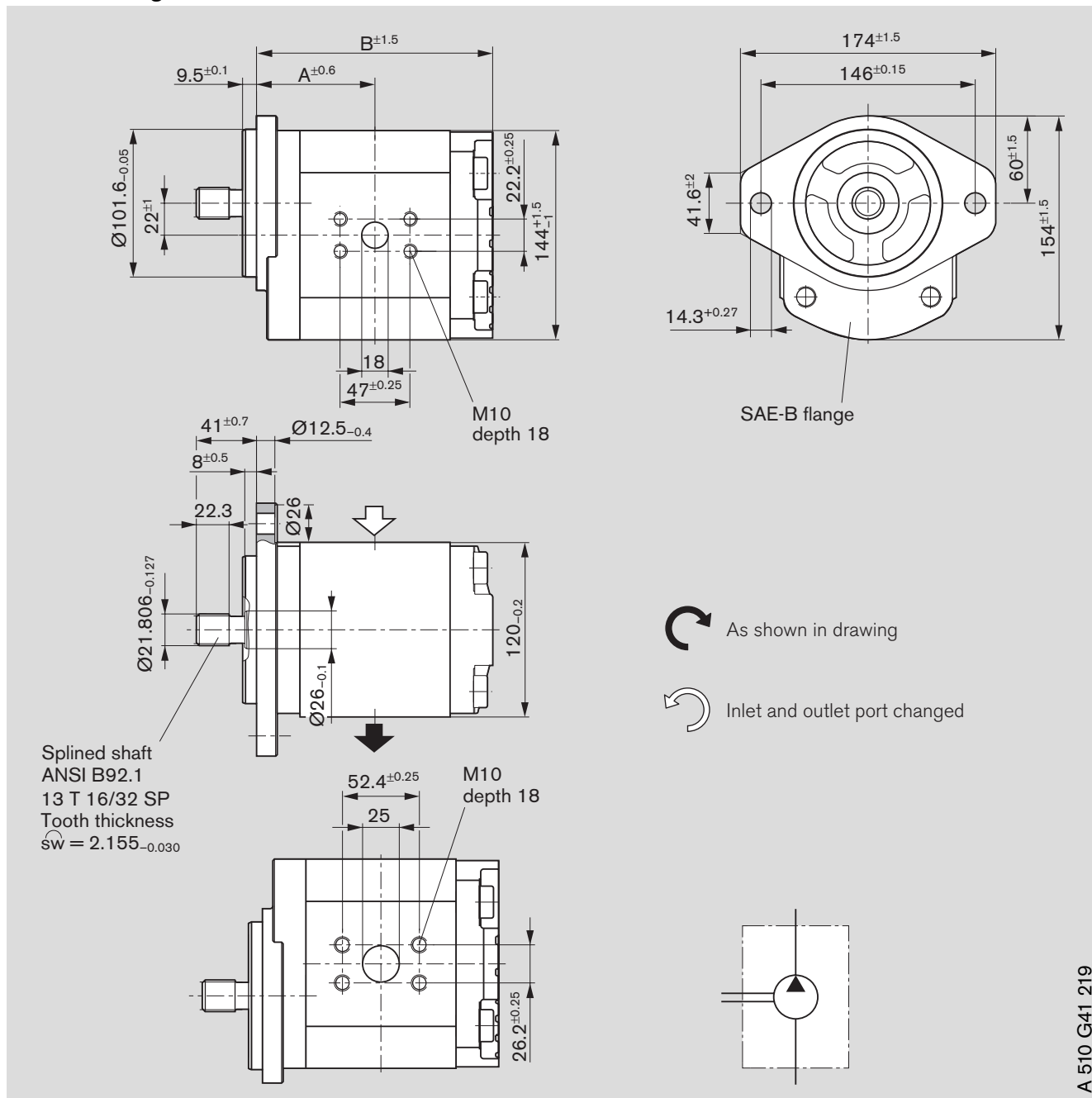

Unit dimensions

Standard range



Ordering code:

AZPG - 22 - D C 07 K B

Displacement [cm ³ /rev]	Ordering-No.		Max. operating pressure [bar]	Max. rotation speed [rpm]	kg	Dimension [mm]	
	 L	 R				A	B
22.5	0 510 725 434	0 510 725 157	280	3000	9.6	66.4	130.1
25	0 510 725 435	0 510 725 158	280	3000	9.7	67.4	132.1
28	0 510 725 436	0 510 725 159	280	3000	9.8	68.7	134.6

Unit dimensions

Standard range

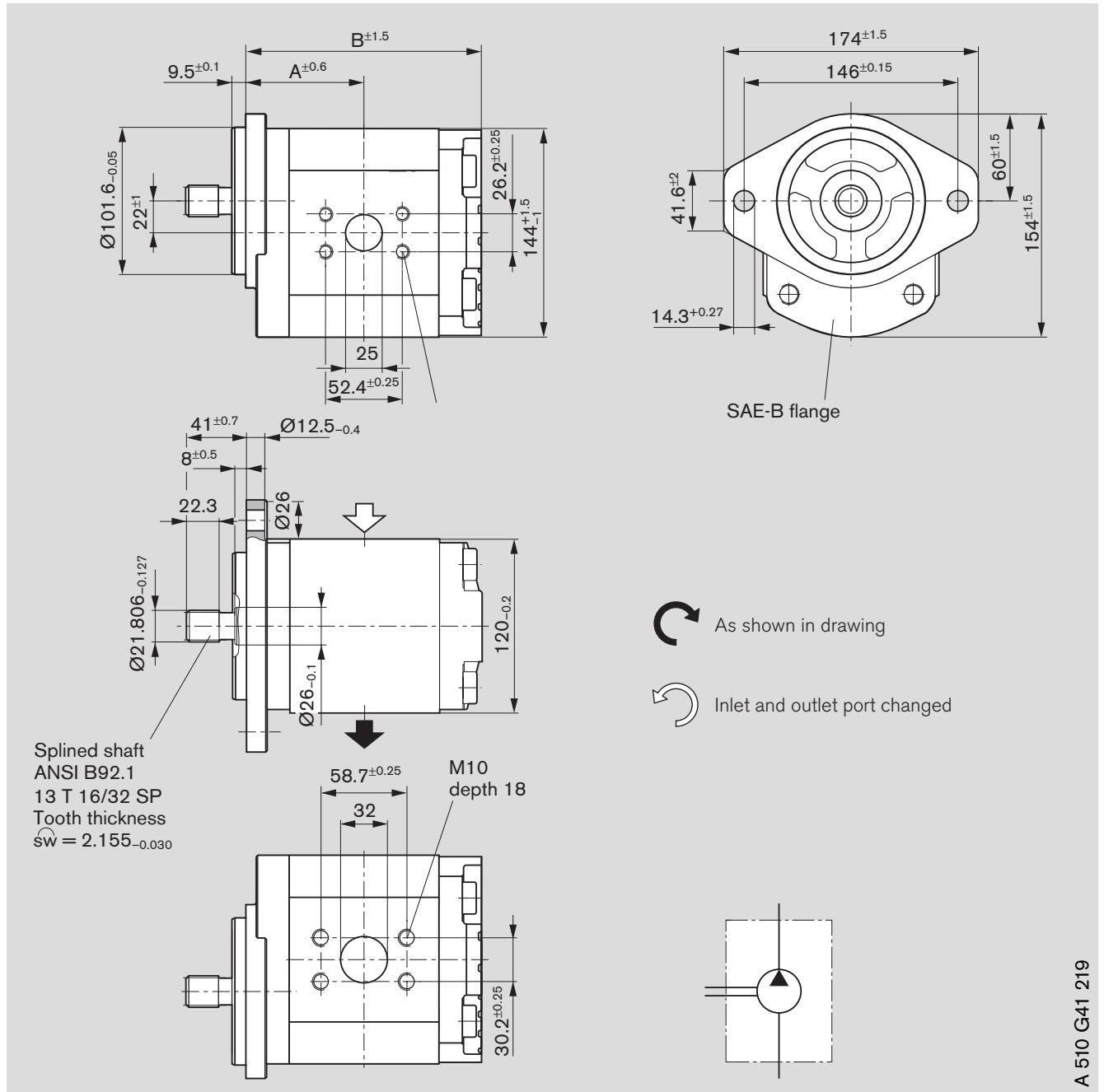

A 510 G41 219

Ordering code:

AZPG - 22 - D C 07 K B

Displacement [cm ³ /rev]	Ordering-No.		Max. operating pressure [bar]	Max. rotation speed [rpm]	kg	Dimension [mm]	
	L	R				A	B
32	0 510 725 437	0 510 725 160	280	2800	10.0	70.3	137.9
36	0 510 725 438	0 510 725 161	280	2800	10.1	71.9	141.2
40	0 510 725 439	0 510 725 162	280	2800	10.3	73.6	144.5
45	0 510 725 440	0 510 725 163	280	2600	10.5	75.6	148.6
50	0 510 825 321	0 510 825 021	250	2600	10.7	77.7	152.7

Unit dimensions

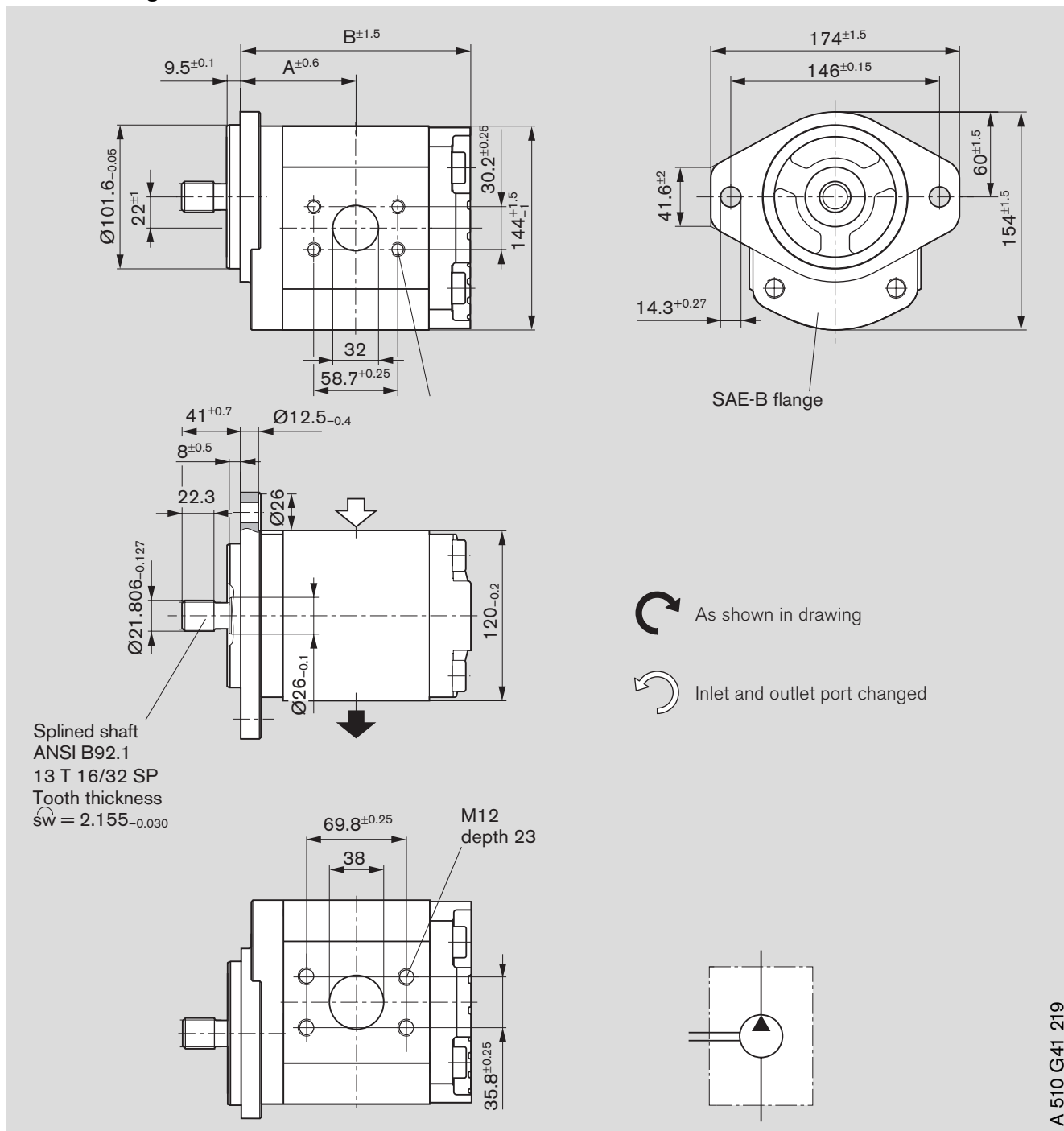

Standard range



A 510 G41 219

Ordering code:

AZPG - 22 - DC 07 KB

Displacement [cm ³ /rev]	Ordering-No.		Max. operating pressure [bar]	Max. rotation speed [rpm]	kg	Dimension [mm]	
	 L	 R				A	B
56	0 510 825 322	0 510 825 022	225	2300	11.0	80.2	157.7
63	0 510 825 323	0 510 825 023	200	2300	11.3	83.1	163.5

Fittings

Fittings can be used for rectangular flange **20** see page 7

Gear pump flange, 90° angle

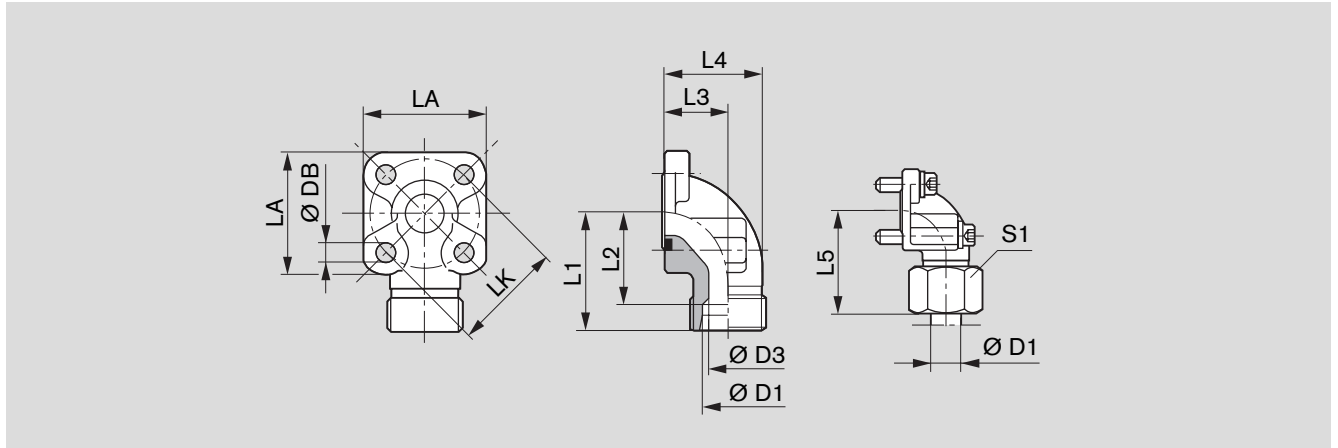

LK	D1	D3	L1	L2	L3	L4	L5	LA	S1	DB	Screws 2x	2x	Seal ring	Mass kg	Part number	<i>p</i> (bar)
55	20S	17	45	34.5	24.0	40.0	56.0	58	36	8.4	M8x25	M8x50	33x2.5	0.44	1 515 702 004	250
55	30S	26	49	35.5	32.0	50.0	62.0	58	50	8.4	M8x25	M8x50	33x2.5	0.50	1 515 702 006	250
55	35L	31	49	38.5	32.0	51.5	62.0	58	50	8.4	M8x25	M8x60	33x2.5	0.47	1 515 702 005	100
55	42 L	38	49	38.0	40.0	64.5	61.0	58	60	8.4	M8x25	M8x70	33x2.5	0.60	1 515 702 019	100

Complete fittings with seal ring, metric screw set, nuts and olive.

Note

The permissible tightening torques can be found in our publication:

“General operating instructions for external gear units”

RE 07 012-B1.

Spare parts

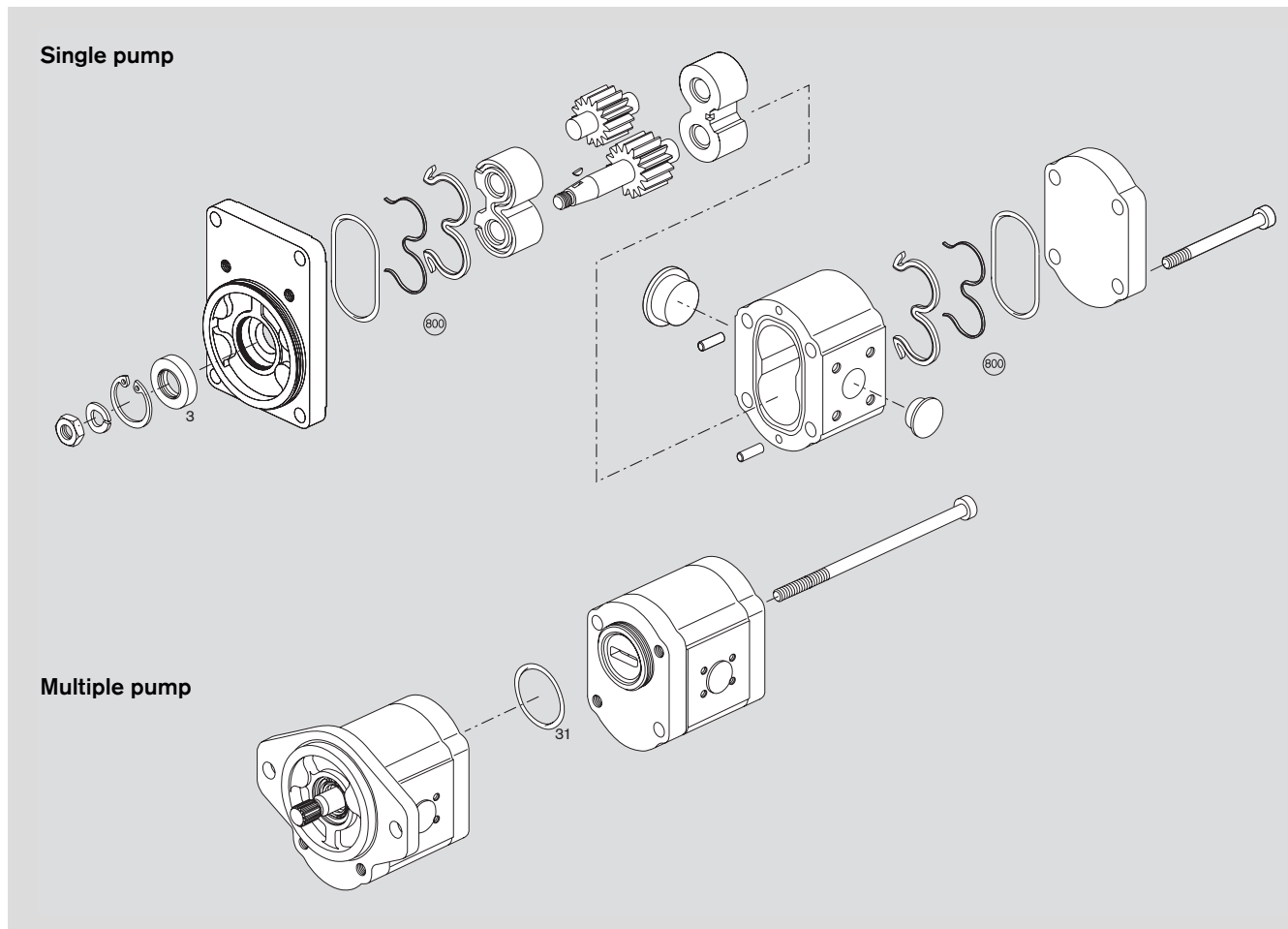

Page	Ordering code	Seal kit "G" Pos. 800 NBR	Shaft seal ring Pos. 3	Dimension	Material
18	AZPG - 22 - □□□ □ C B 20 M B	1517010231	1510283072	42x26x7	NBR
19	AZPG - 22 - □□□ □ H O 30 M B	1517010231	1510283072	42x26x7	NBR
20, 21, 22	AZPG - 22 - □□□ □ D C 07 K B	1517010231	1510283069	42x26x7	FPM

NBR = Perbunan® FPM = Viton®

For multiple pumps

Seal ring Item 31 NBR	1 900 210 145
-----------------------------	---------------

Notes for commissioning

- Fill pump with hydraulic fluid before installation.
- Check direction of rotation.
- Avoid axial and radial forces when mounting the couplings.
- Pipelines to be cleaned of dirt, cinders, sand, chips etc. Pipes, in particular must be pickled or rinsed.
- The introduction of external forces through pipe or hose lines is to be avoided.
- During the initial startup the overall hydraulics system is to be carefully vented. Vertical installations, in particular, with a drive shaft pointing upwards may result in air inclusions near the radial lip-type sealing ring.
- Cover up radial lip-type shaft seal ring when spraying and painting.
- Observe parameters, in particular, speeds and pressures as well as negative pressure in the suction line.
- Allow pump to run without load and have it deliver in depressurized state for several seconds to ensure it is sufficiently lubricated.
- Do not allow pump to run without any oil.
- If, after approx. 20 seconds, the pump is still operating without bubbles then the system should be checked again. Once the operating values have been reached, check pipe connections for signs of leaks. Check operating temperature.

Filter recommendation

The major share of premature failures in gear pumps is due to contaminated hydraulic fluid.

As a warranty cannot be issued for dirt-specific wear, we recommend filtration compliant with cleanliness level 21/18/15 ISO 4406, which reduces the degree of contamination to a permissible dimension in terms of the size and concentration of dirt particles:

Operating pressure [bar]	> 160	< 160
Contamination class NAS 1638	9	10
Contamination class ISO 4406	18/15	19/16
To be reached with $\beta_x = 75$	20	25

We recommend that a full-flow filter always be used.

Basic contamination of the hydraulic fluid used may not exceed class 19/16 as under ISO 4406.

Experience has shown that new fluid quite often lies above this value. In such instances a filling device with special filter should be used.

General

- The pumps supplied by us have been checked for function and performance. No modifications of any kind may be made to the pumps; any such changes will render the warranty null and void!
- Repairs may only be made by the manufacturer or its authorized dealers and subsidiaries. Repairs conducted on their own will render the warranty null and void.

Important notes

- Assembly, maintenance and repair of the pumps to be performed by authorized, skilled and instructed personnel only.
- Pump to be operated at specified data only (see page 14).
- Pump to be operated in proper working condition only.
- System to be depressurized when work conducted on pump.
- Arbitrary conversions and modifications, which affect safety and function are not allowed.
- Mount safety devices (e.g. coupling protection) or do not remove existing ones.
- Make sure that all fixing screws are tight (observe specified tightening torque values).
- General safety and accident prevention regulations must be adhered to.

Project planning notes

Comprehensive notes and suggestions are available in Hydraulics Trainer, Volume 3 RE 00 281, "Project planning notes and design of hydraulic systems".

Where external gear pumps are used we recommend that the following note be adhered to.

Technical data

All stated technical data is dependent on production tolerances and is valid for specific marginal conditions.

Please note that the same dispersion is possible and that technical data may vary under certain marginal conditions (e.g. viscosity).

Characteristics

When designing the engine, please note maximum possible application data based on the characteristics shown on pages 9 to 11.

You can find further information in our publication: "General Operating Instructions for External Gear Units" RE 07 012-B1.