

External gear pump Series B

RE 10 087/11.09
Replaces:
RE 10 087/08.07

AZPB-22...

Fixed pumps
 $V = 1.0...7.1 \text{ cm}^3/\text{rev}$



Overview of contents

Contents	Page
General	2
Product overview	3
Ordering code single pumps	4
Ordering code multiple pumps	5
Drive shaft	6
Front cover	6
Line ports	7
Gear pumps with integrated pressure-relief valve	7
Performance charts	8
Noise charts	11
Design calculations for pumps	12
Specifications	13
Drive Arrangements	14
Multiple gear pumps	15
Unit dimensions	16
Fittings	23
Notes for commissioning	24
Spare parts, schematic diagram	25
Ordering-No.	27

Features

- Nominal pressure 280 bar (up to $5 \text{ cm}^3/\text{rev}$)
- Slide bearings for heavy duty applications
- Standardized drive shafts
- Line ports:
 - Connection flange or internal thread
- Long service life thru reinforced design of shafts and gray cast iron cover
- Consistent high quality thru mass production
- Numerous configuration variants available

General

Rexroth external gear pumps are available as standard gear pumps in the 4 series of B, F, N and G and as SILENCE gear pumps in the series of S, T and U, in which the displacements are graded by different gear widths. Further configuration variants are given by different flanges, shafts, valve arrangements and multiple pump combinations.

Construction

The external gear pump consists essentially of a pair of gears supported in bearing bushings and the case with a front and a rear cover. The drive shaft protrudes from the front cover where it is sealed by the shaft seal ring. The bearing forces are absorbed by special slide bearings with sufficient elasticity to produce surface contact instead of line contact. They also ensure excellent resistance to galling – especially at low speed. The gears have 12 teeth. This keeps both flow pulsation and noise emission to a minimum.

The internal sealing is achieved by forces which are proportional to delivery pressure. This ensures optimum efficiency. The bearings provide the seal at the ends of the gaps between the teeth which carry the pressurized oil. The sealing zone between the gear teeth and the bearings is controlled by the admission of operating pressure to the rear of the bearings. Special seals form the boundary of the zone. The radial clearance at the tips of the gear teeth is sealed by internal forces pushing them against the case.

Axial and radial compensation for gear pump

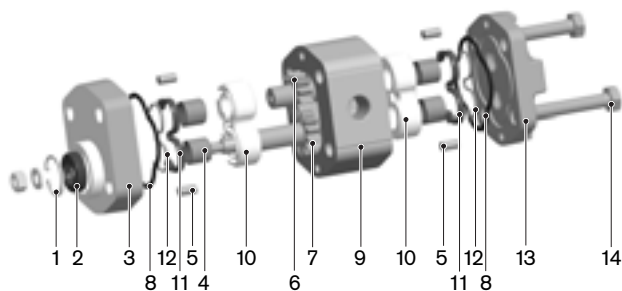
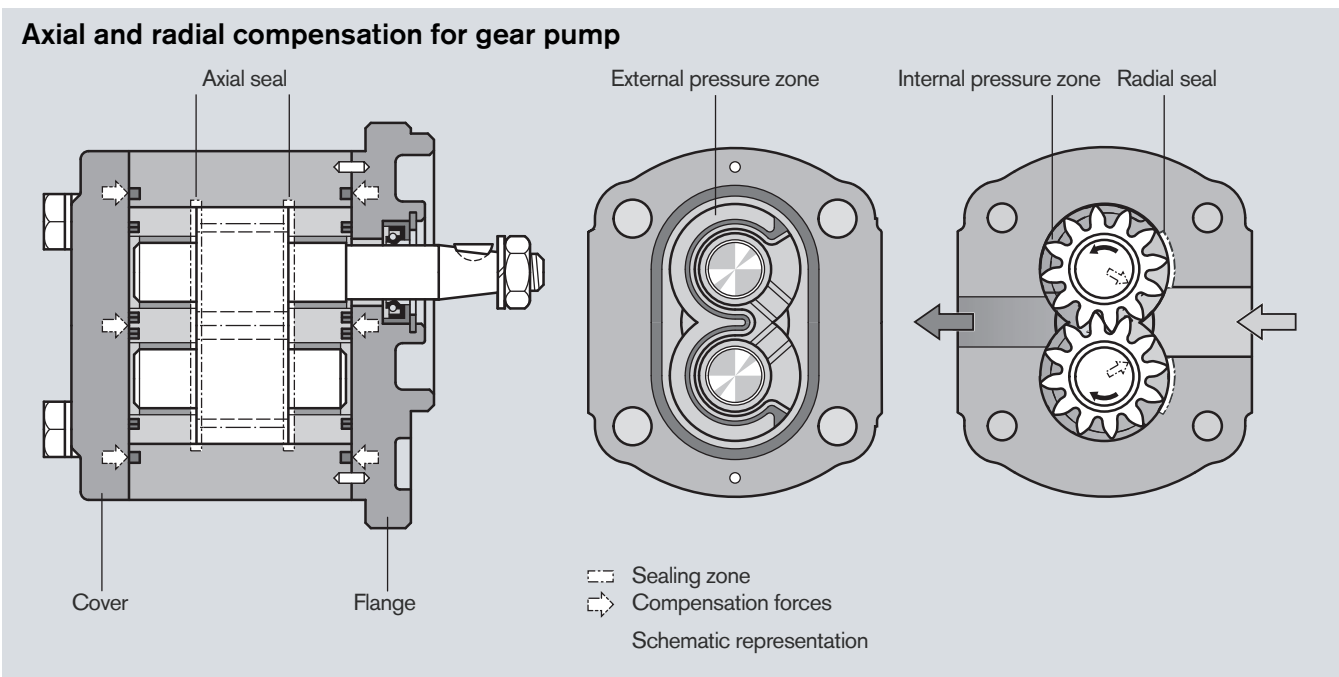

- 1 Retaining ring
- 2 Shaft seal ring
- 3 Front cover
- 4 Slide bearing
- 5 Centering pin
- 6 Gear
- 7 Gear (frictional)
- 8 Case seal
- 9 Pump case
- 10 Bearing
- 11 Axial zone seal
- 12 Support
- 13 End cover
- 14 Fixing screws

Overview of "Series B" standard types

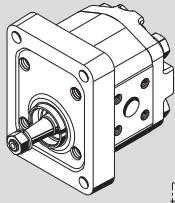
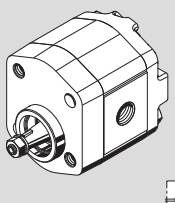
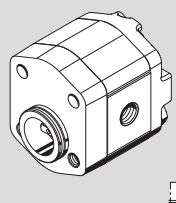
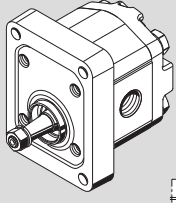
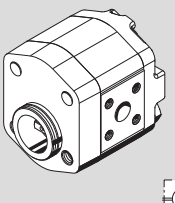
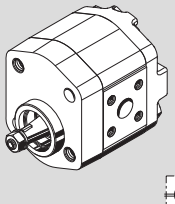
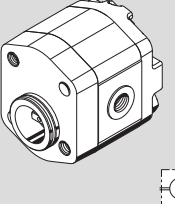









Version	Page	Version	Page	Version	Page
	16		19		22
	17		20		
	18		21		

Ordering code

External gear units Single pumps Standard

AZ	P	B	-	x	x	-	4.0	R	C	P	02	M	D	200 xx	S xxxx
Function P = Pump Series 2 = 2nd generation Version 2 = corrosion-resistant, pinned Size (B) 1.0 = 1.00 cm ³ /rev 2.0 = 2.00 cm ³ /rev 2.5 = 2.50 cm ³ /rev 3.1 = 3.15 cm ³ /rev 4.0 = 4.00 cm ³ /rev 4.5 = 4.50 cm ³ /rev 5.0 = 5.00 cm ³ /rev 6.3 = 6.30 cm ³ /rev 7.1 = 7.10 cm ³ /rev Direction of rotation R = Clockwise L = Counterclockwise							Special design *)		Valve adjustment 200 xx = PRV 200 bar		Rear cover B = Standard D = DBV, internal residual current Seals M = NBR K = NBR, shaft seal ring in FKM P = FKM				

*) Some of the special designs shown on pages 16–22 are not covered in the illustration of the ordering code.

Drive shafts				Front cover				Line ports			
Suitable front cover											
C	Tapered key shaft 1:5		P	P	2-bolt mounting Centering Ø 32 mm		01	Pipe thread ISO 228/1			
H	Tapered key shaft 1:8		O	O	Square flange Centering Ø 25.28 mm		02	Thread, metric ISO 9974-1			
N	Two-surface Claw		M	Y	M 2-bolt mounting Centering Ø 32 mm, with seal ring		20	Rectangular flange			
				Y	2-bolt mounting Centering Ø 32 mm, with seal ring, mounting on series F						

Not all variants can be selected by using ordering code!



























Please select the required pump by using the selection tables (standard types) or after consultation with Bosch Rexroth!

Special options are possible upon request.

Ordering code

External gear units, Multiple pumps, Standard

AZ	P	BB	-	x	x	-	4.0/4.0	R	H	O	20 20	K	B
Function P = Pump Series B = 1.0...71 cm ³ /rev S = 4.0...28 cm ³ /rev F = 4.0...28 cm ³ /rev T = 20.0...36 cm ³ /rev N = 20.0...36 cm ³ /rev U = 22.5...63 cm ³ /rev G = 22.5...63 cm ³ /rev Series , relates to pump section 1 2 = Case width 110 mm Version , relates to pump section 1 2 = corrosion-resistant, pinned Size as per individual Series Direction of rotation R = Clockwise L = Counterclockwise							Rear cover relates to last pump stage B = Standard Seals M = NBR K = NBR, shaft seal ring pump stage 1 in FKM P = FKM						

Drive shafts relates to pump stage 1				Front cover relates to pump stage 1				Line ports every pump stage			
Series B:				Suitable front cover							
H	Tapered key shaft 1:8		O	O	Square flange Centering Ø 25.38 mm		01	Pipe thread ISO 228/1			
							20	Rectangular flange			
Series F, S:											
C	Tapered key shaft 1:5		B	B	Square flange Centering Ø 80 mm		20	Rectangular flange			
H	Tapered key shaft 1:8		O	O	Square flange Centering Ø 36.47 mm		30	Rectangular flange			
R	Splined shaft SAE J 744 16-4 9T		R	R	SAE J 744 82-2 A Centering Ø 82.55 mm 2-hole mounting						
Series N, T:											
C	Tapered key shaft 1:5		B	B	Square flange Centering Ø 100 mm		07	Square flange SAE thread, metric			
D	Splined shaft SAE J 744 22-4 13T		C	C	SAE J 744 101-2 B Centering Ø 101.6 mm 2-hole mounting		20	Rectangular flange			
Series G, U:											
C	Tapered key shaft 1:5		B	B	Square flange Centering Ø 105 mm		07	Square flange SAE thread, metric			
D	Splined shaft SAE J 744 22-4 13T		C	C	SAE J 744 101-2 B Centering Ø 101.6 mm 2-hole mounting		20	Rectangular flange			
H	Tapered key shaft 1:8		O	O	Square flange Centering Ø 50.78 mm		30	Rectangular flange			

Not all variants can be selected by using ordering code!

Please select the required pump by using the selection tables (standard types) or after consultation with Bosch Rexroth!

Special options are possible upon request.

Drive shafts

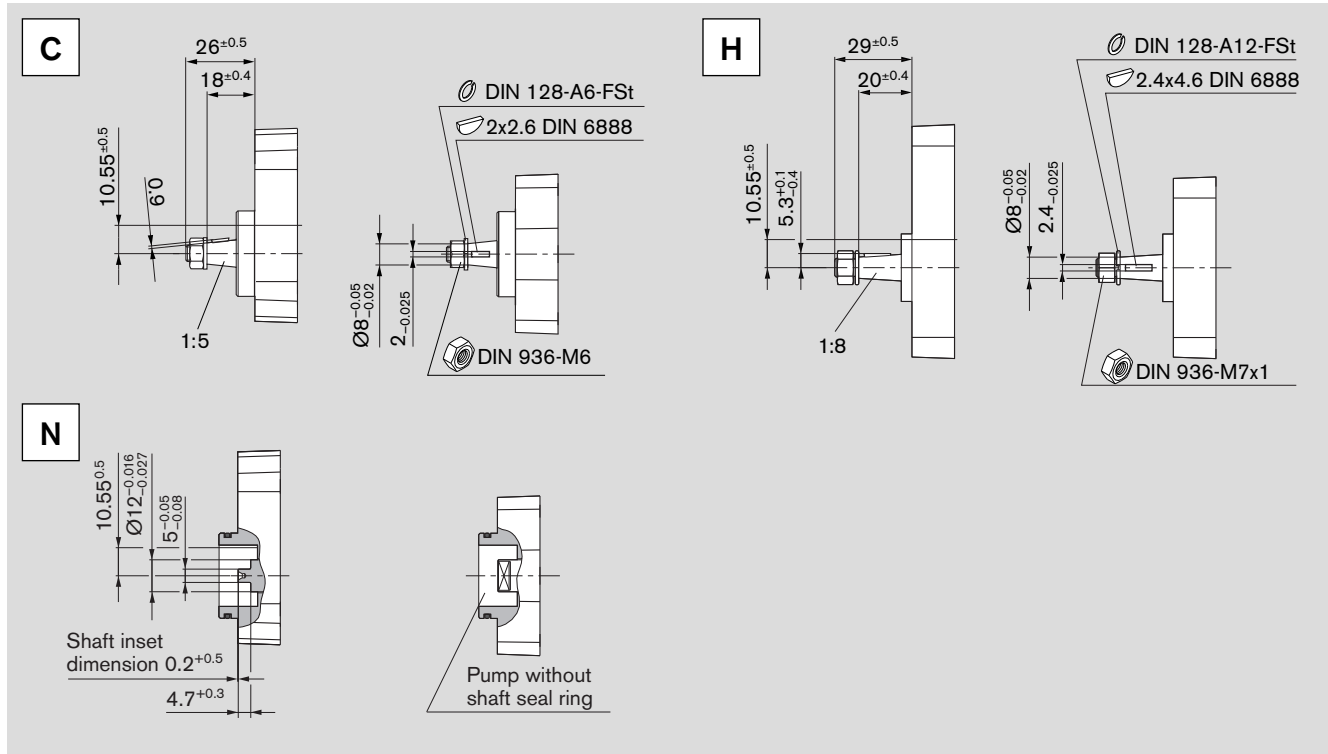

Front cover

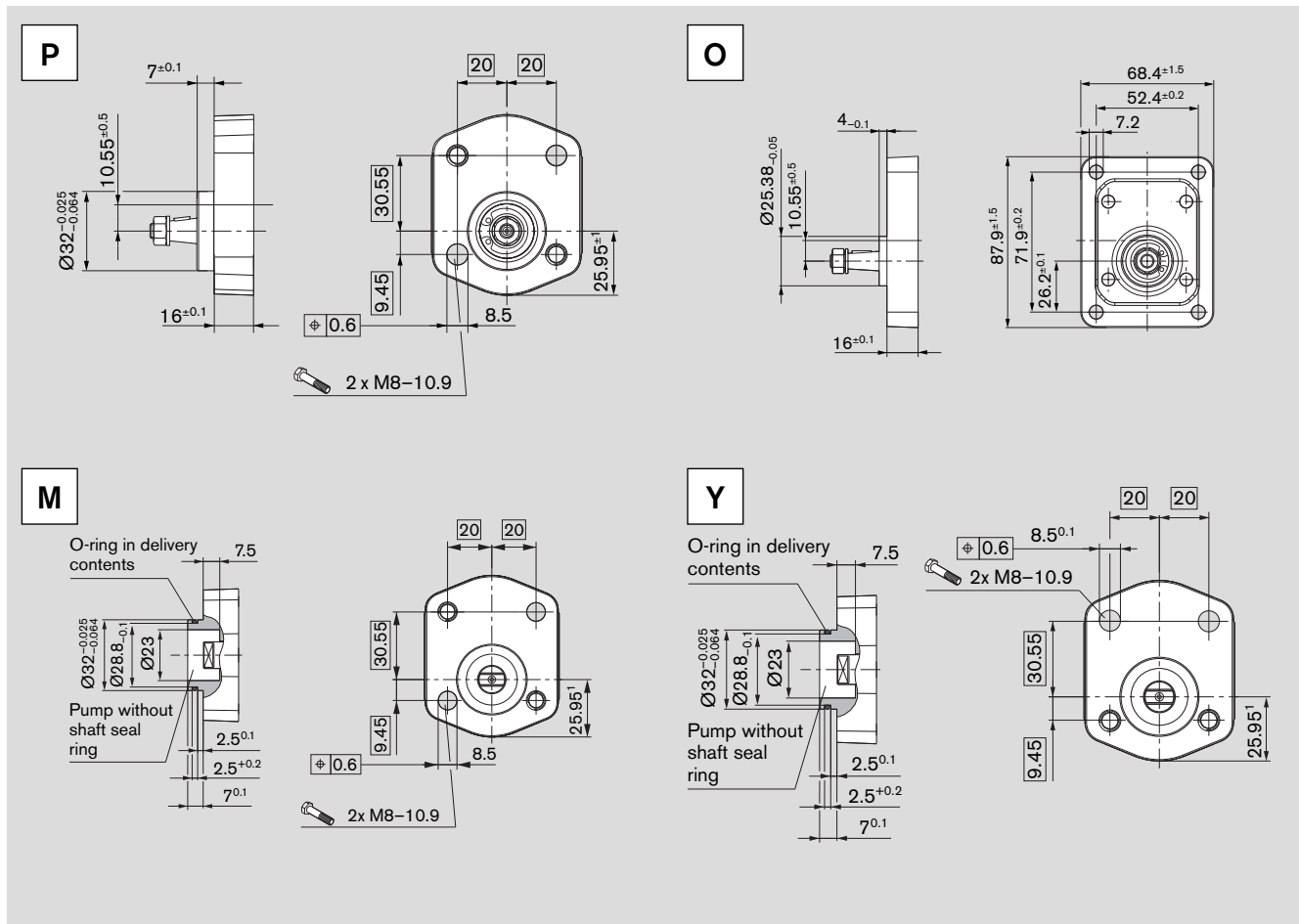

Line ports

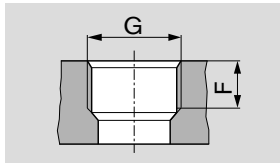

01 Pipe thread
ISO 228/1

Limited service life
compared to line port **20**

Ordering code	Size	Pressure side		Suction side	
		G	F	G	F
01	1...3.15 cm ³	G 3/8	13	G 3/8	13
	4.0...7.1 cm ³	G 3/8		G 1/2	

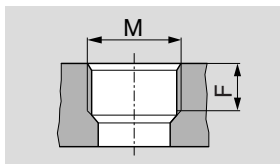

02 Pipe thread
ISO 9974-1

Limited service life
compared to line port **20**

Ordering code	Size	Pressure side		Suction side	
		M	F	M	F
02	1...3.15 cm ³	14 x 1.5	13	M18 x 1.5	13
	4...7.1 cm ³			M22 x 1,5	

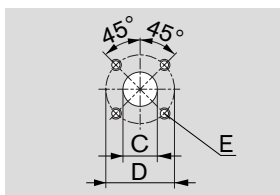

20 Rectangular flange

Ordering code	Size	Pressure side			Suction side		
		C	D	E	C	D	E
20	2...3.5 cm ³	12	30	M 6 depth 13	12	30	M 6 depth 11.5
	3.15...7.1 cm ³	15	35		15	35	

Gear pumps with integrated pressure-relief valve

In order to reduce external pipework it is possible to incorporate a pressure-relief valve in the cover of the gear pump.

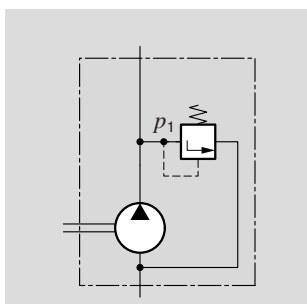

Pressure-relief valve.
Discharge returned to suction line
 $p_1 = 5...250$ bar

Performance charts

$\nu = 35 \text{ mm}^2/\text{s}$, $\vartheta = 50^\circ\text{C}$

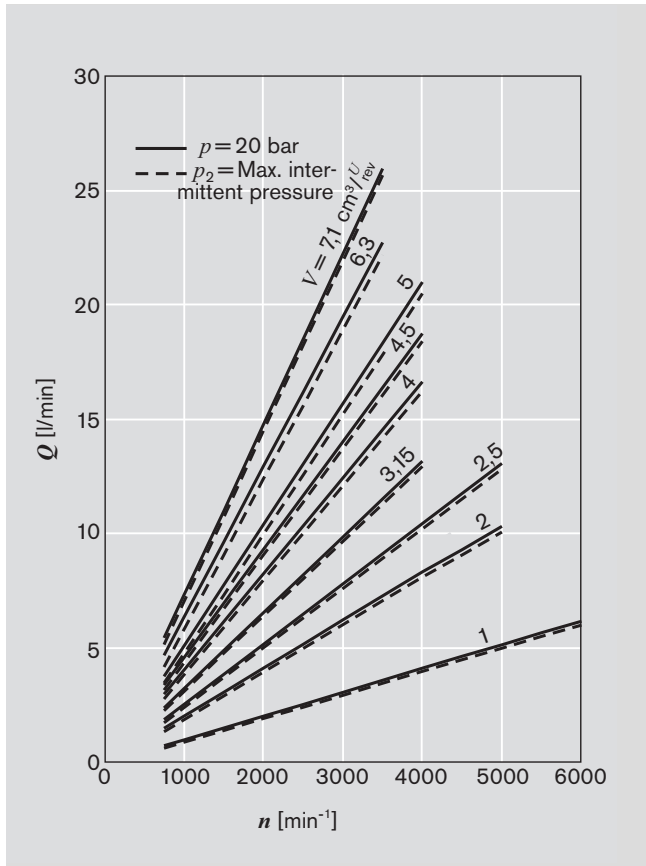

$Q = f(n, V)$ incl. η_v
 $P = f(n, p)$ — incl. η_t
 $M = f(n, p)$ - - - incl. η_{hm}

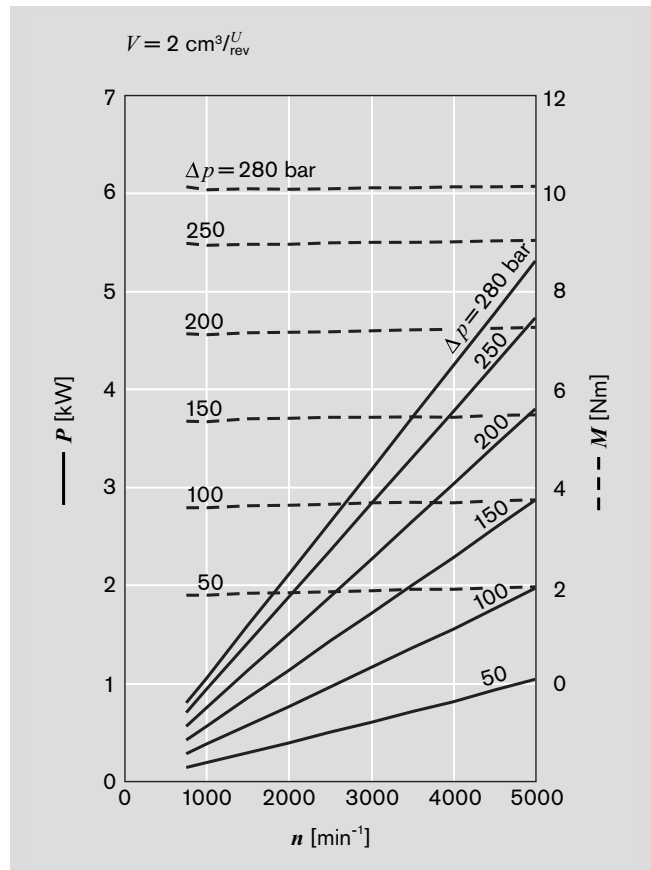
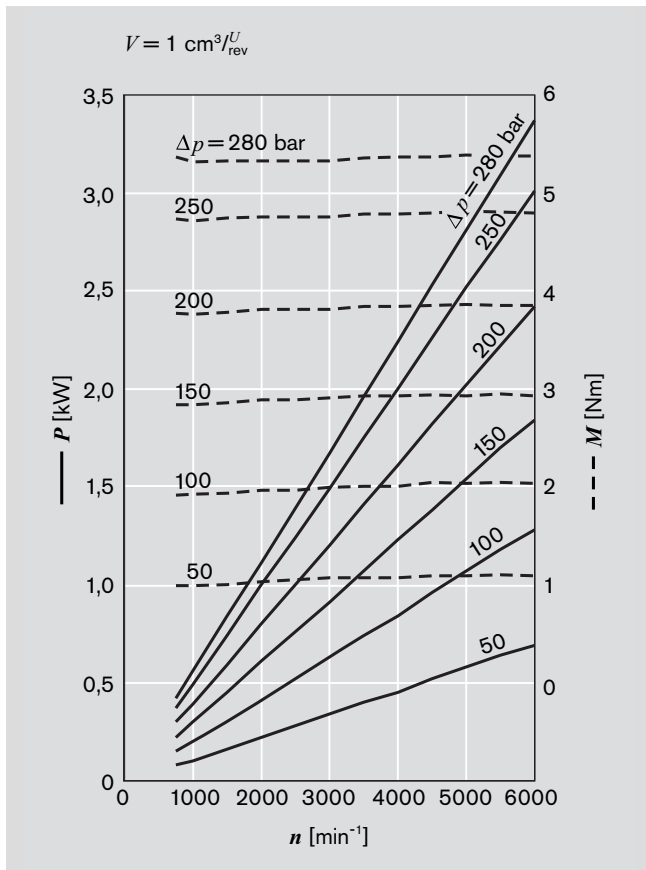

Performance charts (continued)

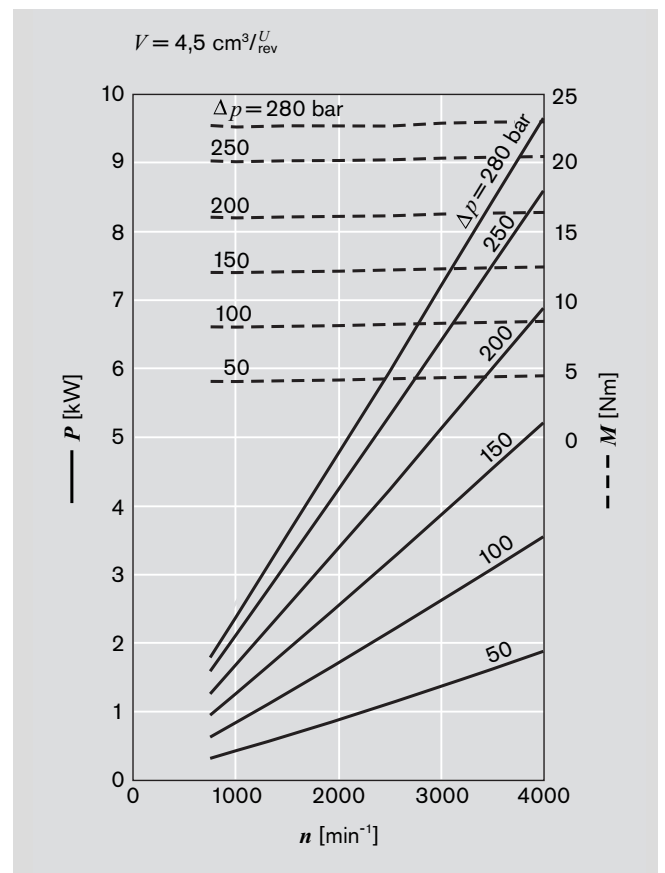
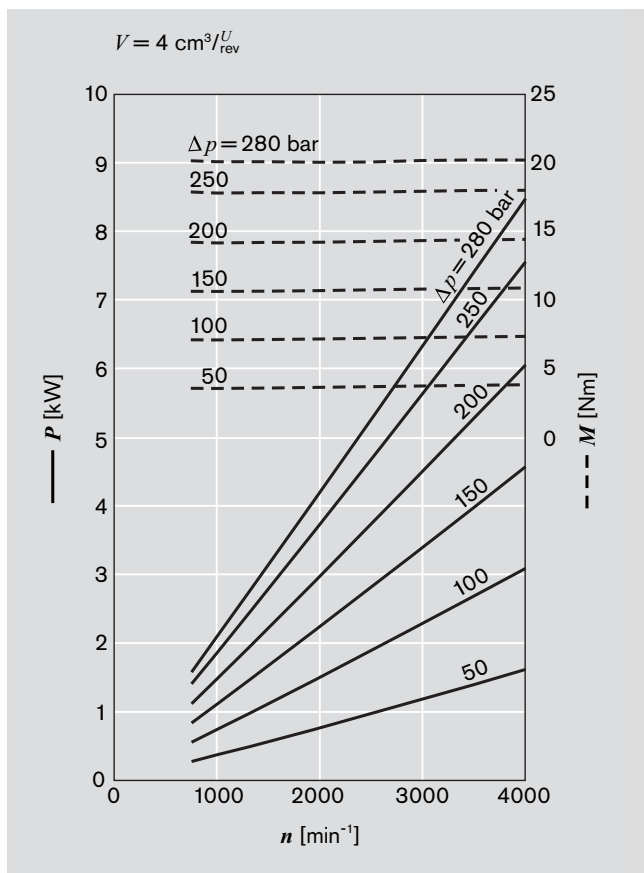
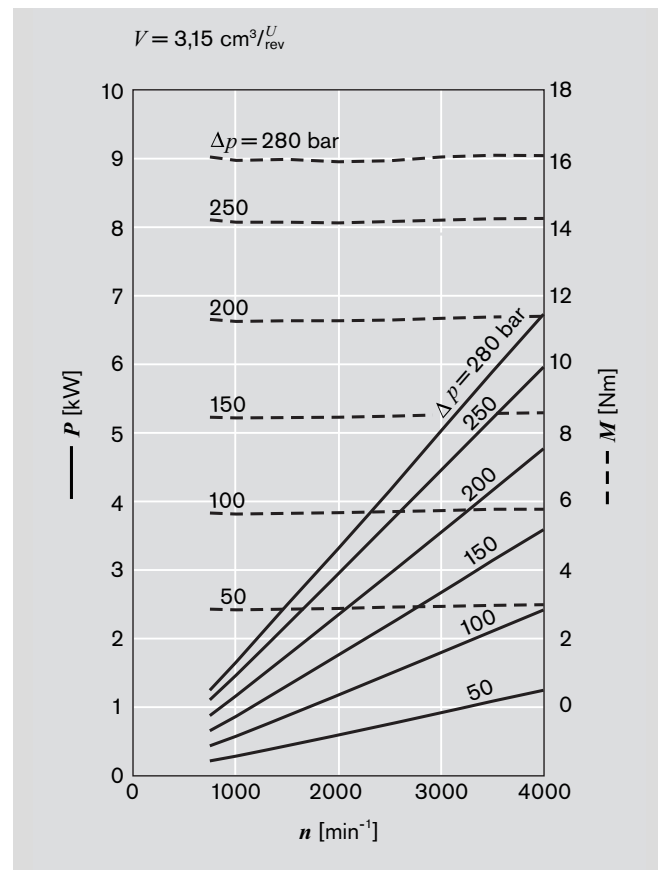
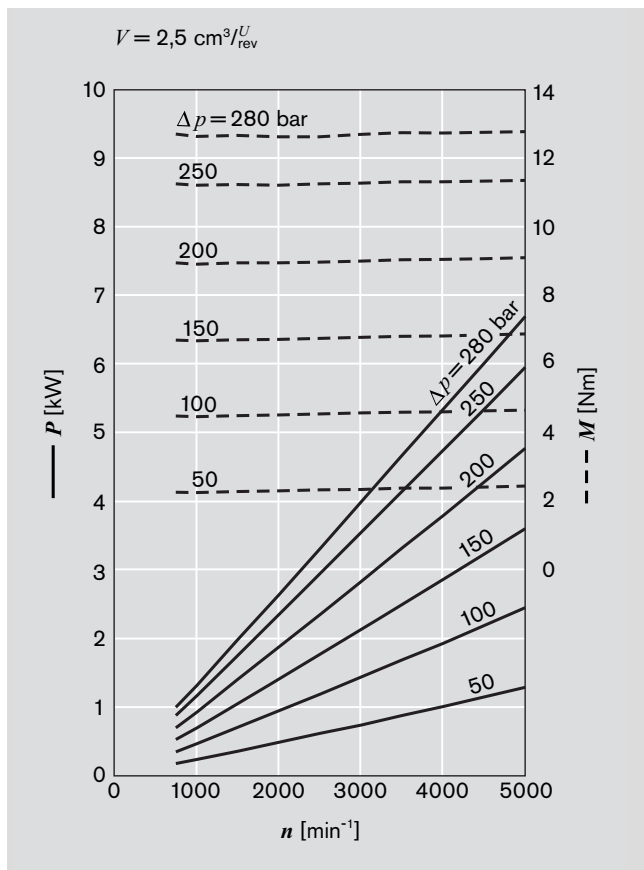

Performance charts (continued)

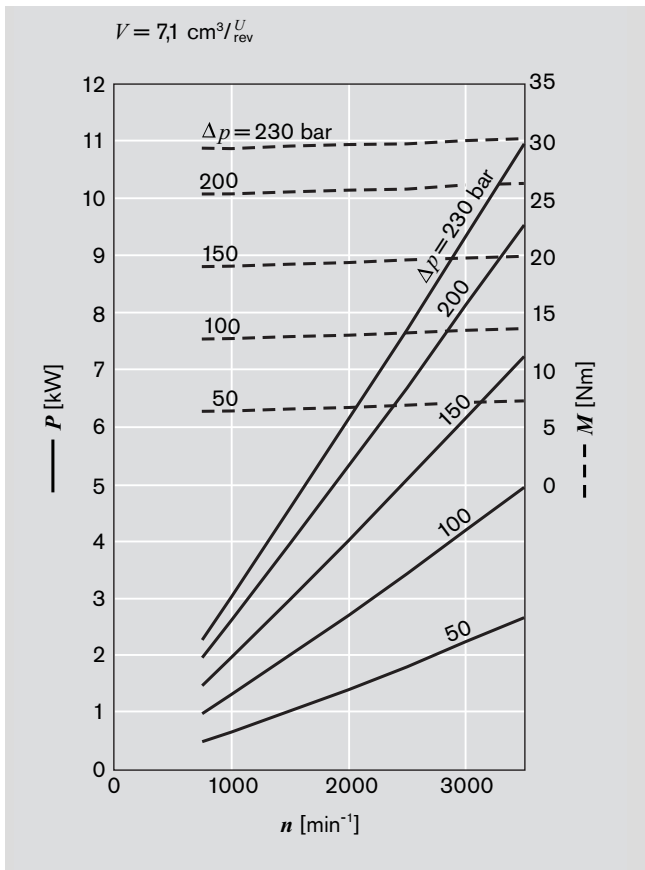
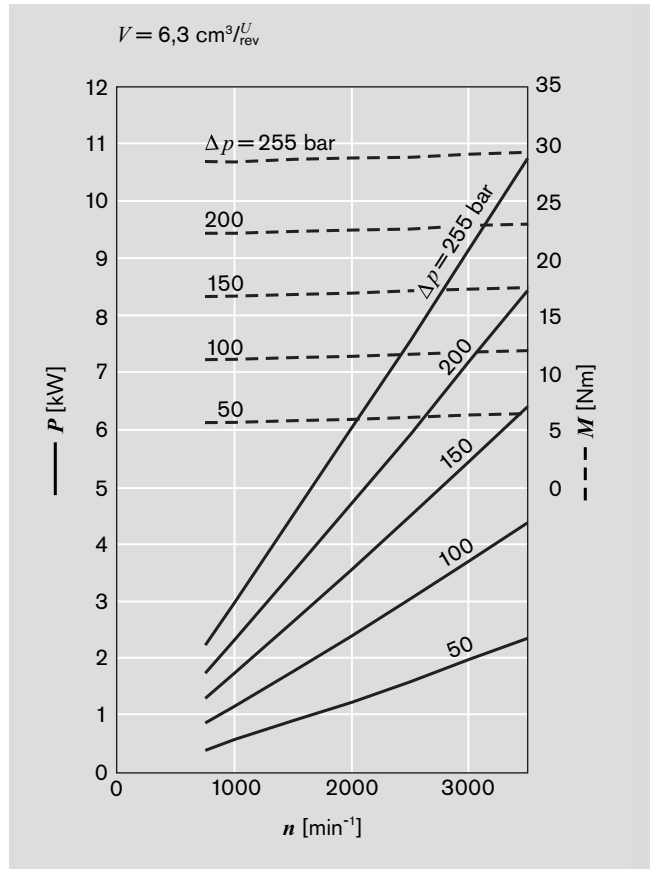
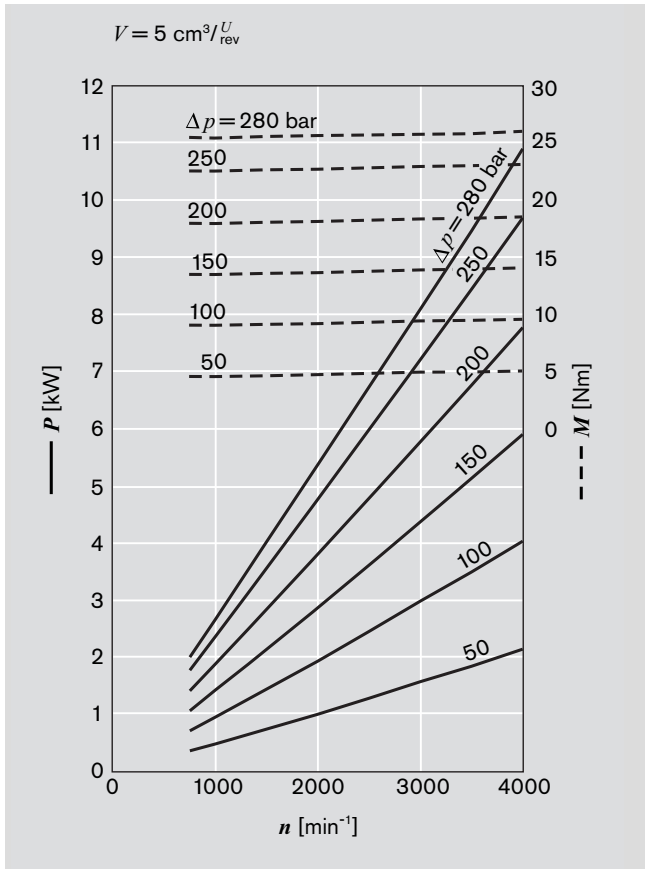

Noise charts

Noise level dependent on rotational speed, pressure range between 10 bar and pressure value p_2 (see page 13 Specifications table).

Oil data: $\nu = 32 \text{ mm}^2/\text{s}$, $\vartheta = 50^\circ\text{C}$.

Sound pressure level calculated from noise measurements made in the sound absorbent measuring room compliant with DIN 45635, Part 26.

Spacing between measuring sensor – pump: 1 m.

These are typical characteristic values for the respective model. They describe the airborne sound emitted solely by the pump. Environmental influences (installation site, piping, further system components) are not taken into consideration. Each value applies for a single pump.

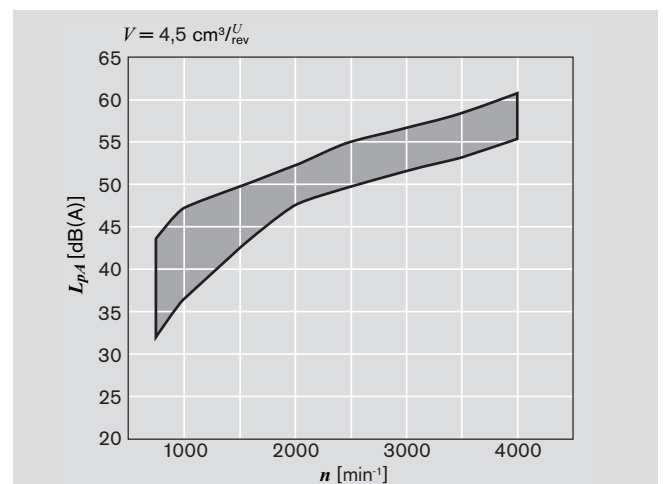
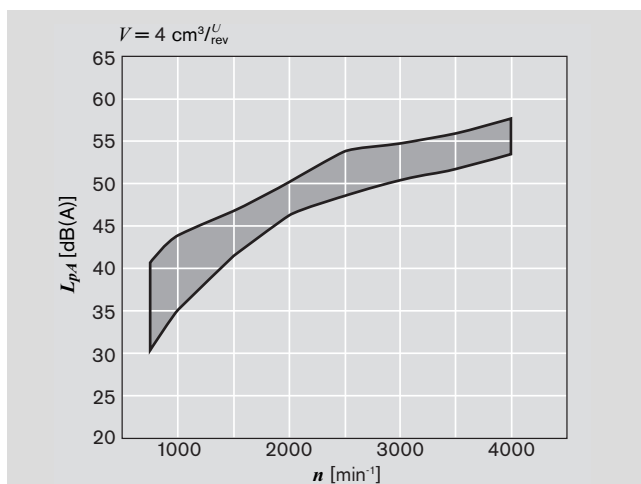
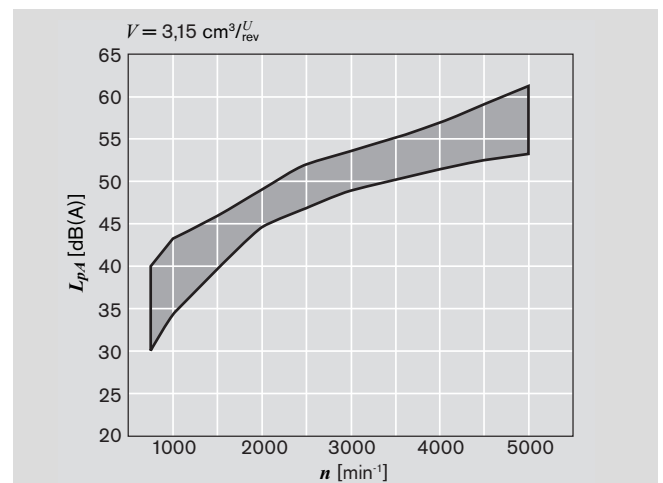
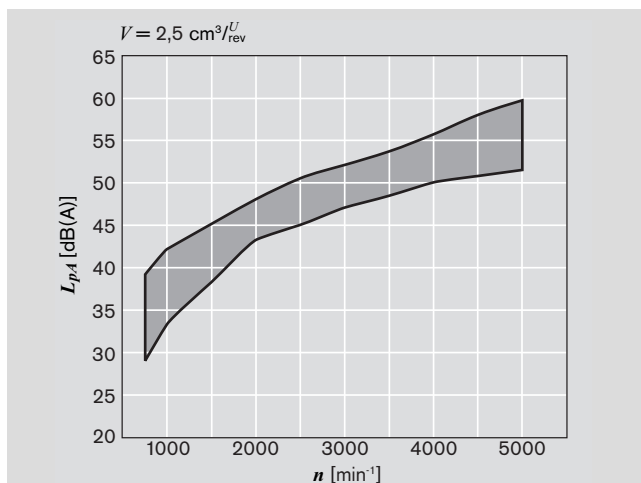
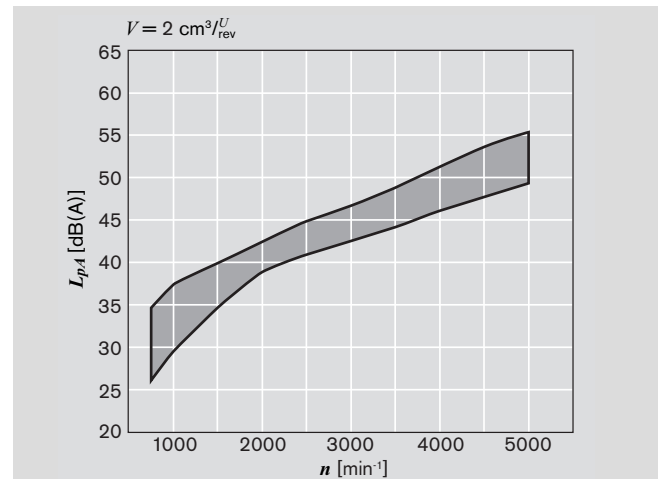
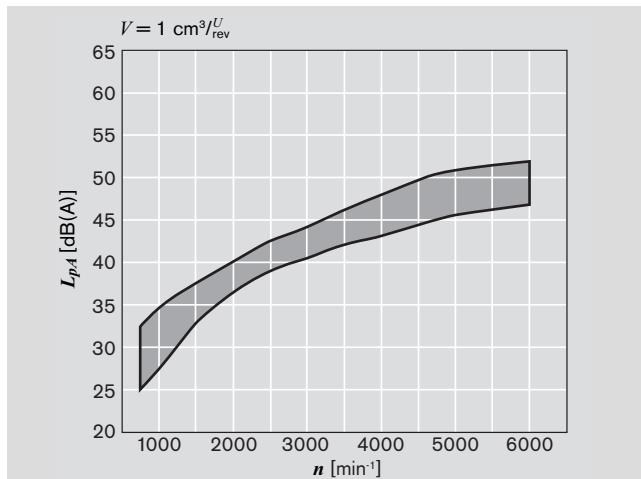

Noise charts (continued)

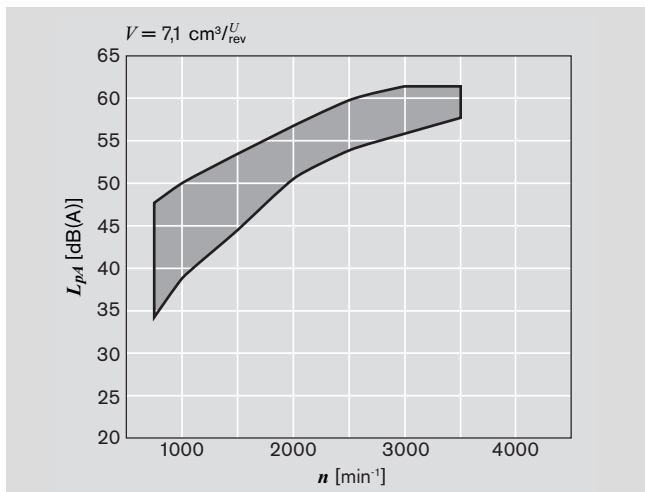
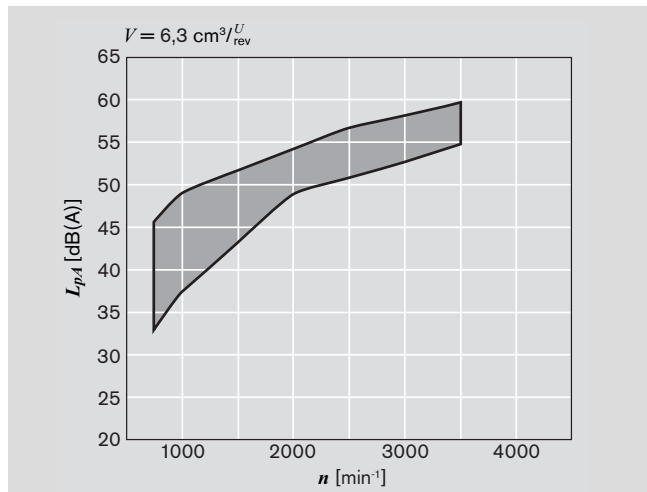
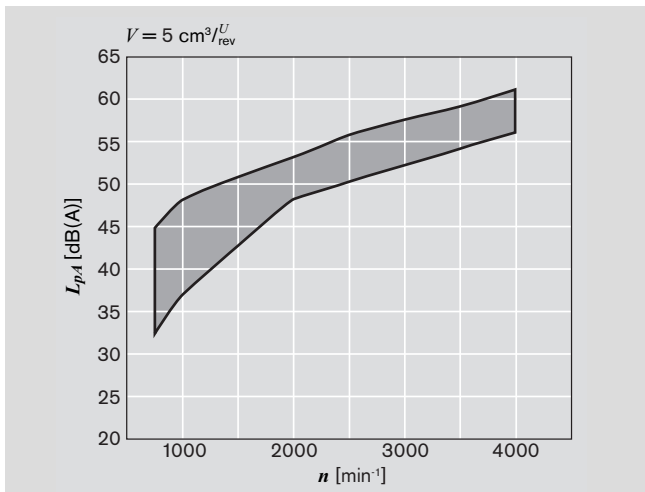

Design calculations for pumps

The design calculations for pumps are based on the following parameters:

- V [cm³/rev] Displacement
- Q [l/min] Delivery
- p [bar] Pressure
- M [Nm] Drive torque
- n [rev/min] Drive speed
- P [kW] Drive power

It is also necessary to allow for different efficiencies such as:

- η_v Volumetric efficiency
- η_{hm} Hydraulic-mechanical efficiency
- η_t Overall efficiency

The following formulas describe the various relationships.

They include correction factors for adapting the parameters to the usual units encountered in practice.

Caution: Diagram for approximate selection data can be found on pages 8...10.

$$Q = V \cdot n \cdot \eta_v \cdot 10^{-5}$$

$$p = \frac{M \cdot \eta_{hm}}{1.59 \cdot V}$$

$$P = \frac{p \cdot Q}{6 \cdot \eta_t}$$

$$V = \frac{Q}{n \cdot \eta_v} \cdot 10^5$$

$$V = \frac{M \cdot \eta_{hm}}{159 \cdot p}$$

$$Q = \frac{6 \cdot P \cdot \eta_t}{p}$$

$$n = \frac{Q}{V \cdot \eta_v} \cdot 10^5$$

$$M = \frac{1.59 \cdot V \cdot p}{\eta_{hm}}$$

$$p = \frac{6 \cdot P \cdot \eta_t}{Q}$$

[%]

n — η_v —→ Q V [cm³/rev] Q [l/min] p [bar]

M — η_{hm} —→ p

P — η_t —→ p · Q n [rev/min] P [kW] M [Nm]

Caution: η [%] e.g. 95 [%]

Specifications

General	
Construction	External gear pump
Mounting	Flange or through-bolting with spigot
Line ports	Internal thread, flange
Direction of rotation (looking on shaft)	Clockwise or counterclockwise, the pump may only be driven in the direction indicated
Installation position	Any
Load on shaft	Radial and axial forces after consulting
Ambient temperature range	-30°C...+80°C with NBR seal -20°C...+110°C with FKM seals
Fluids	- Mineral oil compliant with DIN 51 524, 1-3, however under higher load at least HLP compliant with DIN 51 524 Part 2 recommended. - Comply with RE 90220 - Further operating fluids possible after consultation
Viscosity	12...800 mm ² /s permissible range 20...100 mm ² /s recommended range ...2000 mm ² /s permissible range for start up
Fluid temperature range	max. +80°C with NBR seals max. +110°C with FKM seals
Filtration *)	At least cleanliness level 20/18/15 compliant with ISO 4406 (1999)

*) During the application of control systems or devices with critical counter-reaction, such as steering and brake valves, the type of filtration selected must be adapted to the sensitivity of these devices/systems.

Safety requirements pertaining to the whole systems are to be observed.

In the case of applications with high numbers of load cycles please consulting.

Definition of direction of rotation

Always look on the drive shaft.

Caution: Dimensions drawings always show clockwise-rotation pumps. On counterclockwise-rotation pumps the positions of the drive shaft and the suction and pressure ports are different.

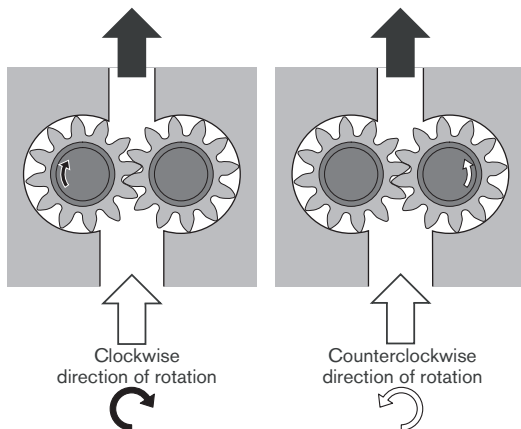

Definitions of pressures

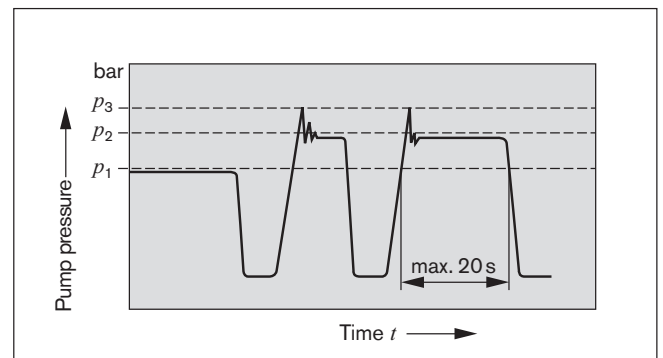

p_1 max. continuous pressure
 p_2 max. intermittent pressure
 p_3 max. peak pressure

AZPB-22

Displacement	V	cm ³ /rev	1	2	2.5	3.15	4	4.5	5	6.3	7.1
Suction pressure	p_e	bar	0.7...3 (absolute)								
max. continuous pressure	p_1		250	250	250	250	250	250	250	225	200
max. intermittent pressure	p_2		280	280	280	280	280	280	280	255	230
max. peak pressure	p_3		300	300	300	300	300	300	300	275	250
min. rotational speed		rpm	750	750	750	750	750	750	750	750	750
max. rotational speed at	p_2		6,000	5,000	5,000	4,000	4,000	4,000	4,000	3,500	3,500

Drive arrangement

The coupling must not transfer any radial or axial forces to the pump.

1. Flexible couplings

Refer to the fitting instructions provided by the coupling manufacturer for details of the maximum permitted shaft misalignment.

The maximum radial runout of pump shaft spigot is 0.2 mm.

2. Drive shaft with tang

For the close-coupling of the pumps to electric motor or internal-combustion engine, gear, etc. The pump shaft has a special tang and driver ③ (not included in supply).

There is no shaft sealing.

The recommended arrangements and dimensions for the drive end and sealing are as follows.

Transferrable torque:

AZPB-22 = 25 Nm.

Suitable couplings for AZPB-22:

1 510 001 002 for AZPFB,

1 510 240 001 for AZPBB.

① Drive shaft

Case-hardening steel DIN 17 210

e.g. 20 MnCrS 5

case-hardened 1.0 deep; HRA 83 \pm 2

Surface for sealing ring
ground without rifling $R_t \leq 4\mu\text{m}$

② Radial shaft seal

with rubber covered seal
(see DIN 3760, Type AS, or
double-lipped ring).

Please take note of the seal ring manufacturer's guidelines for arrangement of the installation space.

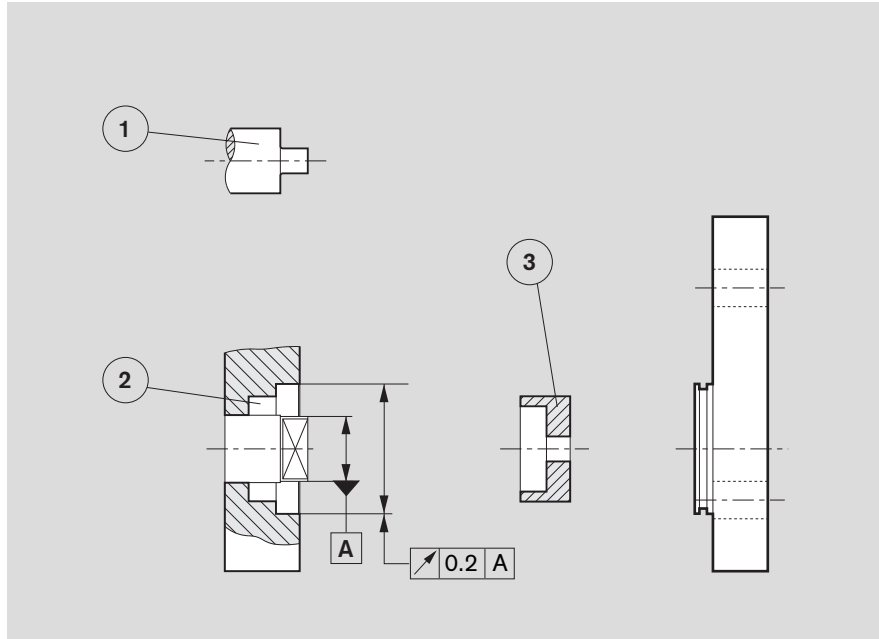
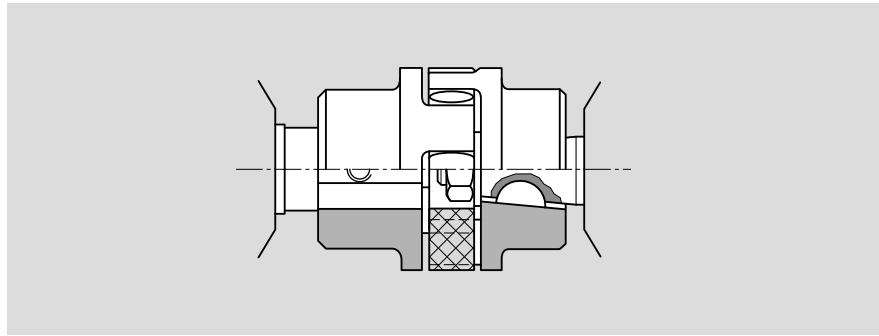

Multiple gear pumps

Gear pumps are suitable for multiple setups, whereby the drive shaft for the 1st pump is extended to a second and even a 3rd pump. A coupling is fitted between each pair of pumps.

In most cases each pump is isolated from its neighbor, i.e. the suction ports are separate from one another. A common suction port is also possible as an option.

Caution: Basically, the specifications for the single pumps apply, but with certain restrictions:

Max. speed: This is determined by the highest rated pump speed in use.

Pressures: These are restricted by the strength of the drive shaft, the through drives and the drivers. Appropriate data is given in the dimensional drawings.

Pressure restrictions

In the case of series B (AZPB-22), the driver for the second pumping stage can carry a load of up to $M_{max.} = 25$ Nm, i.e. there is a pressure restriction for the second stage and any further stages.

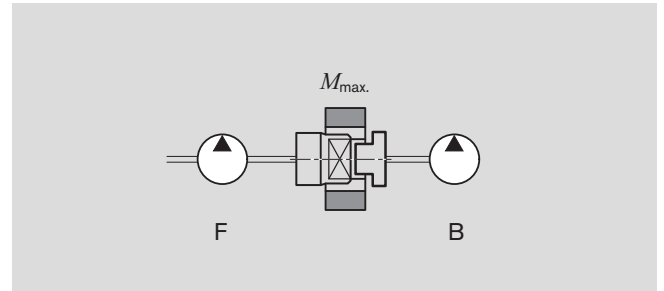

Combinations

Series Pump 1	$M_{max.}$ [Nm]	Series Pump 2
F	25	B
B	25	B

For configuration of multiple pumps we recommend the pump is positioned with the largest displacement on the drive side.

Drive shaft		max. transferrable drive torque * [Nm]
C	1:5	26
H	1:8	30
N	Claw	25

* These values only apply when the conditions described above are complied with. Bosch Rexroth is to be consulted if the stated values are exceeded.

If the first stage is driven through a tang (driver) or outboard bearing type 1, pressure restrictions apply as indicated in the formula below.

Reinforced through drives are available for applications with higher transfer torques and/or rotational vibrations. Customized designs available on request.

$$M_{max.} \cong \Delta p_1 \cdot V_1 \cdot 0.0177 + \Delta p_2 \cdot V_2 \cdot 0.0177 + \Delta p_3 \cdot V_3 \cdot 0.0177$$

Δp [bar] V [cm³/rev]

Unit dimensions

Standard range

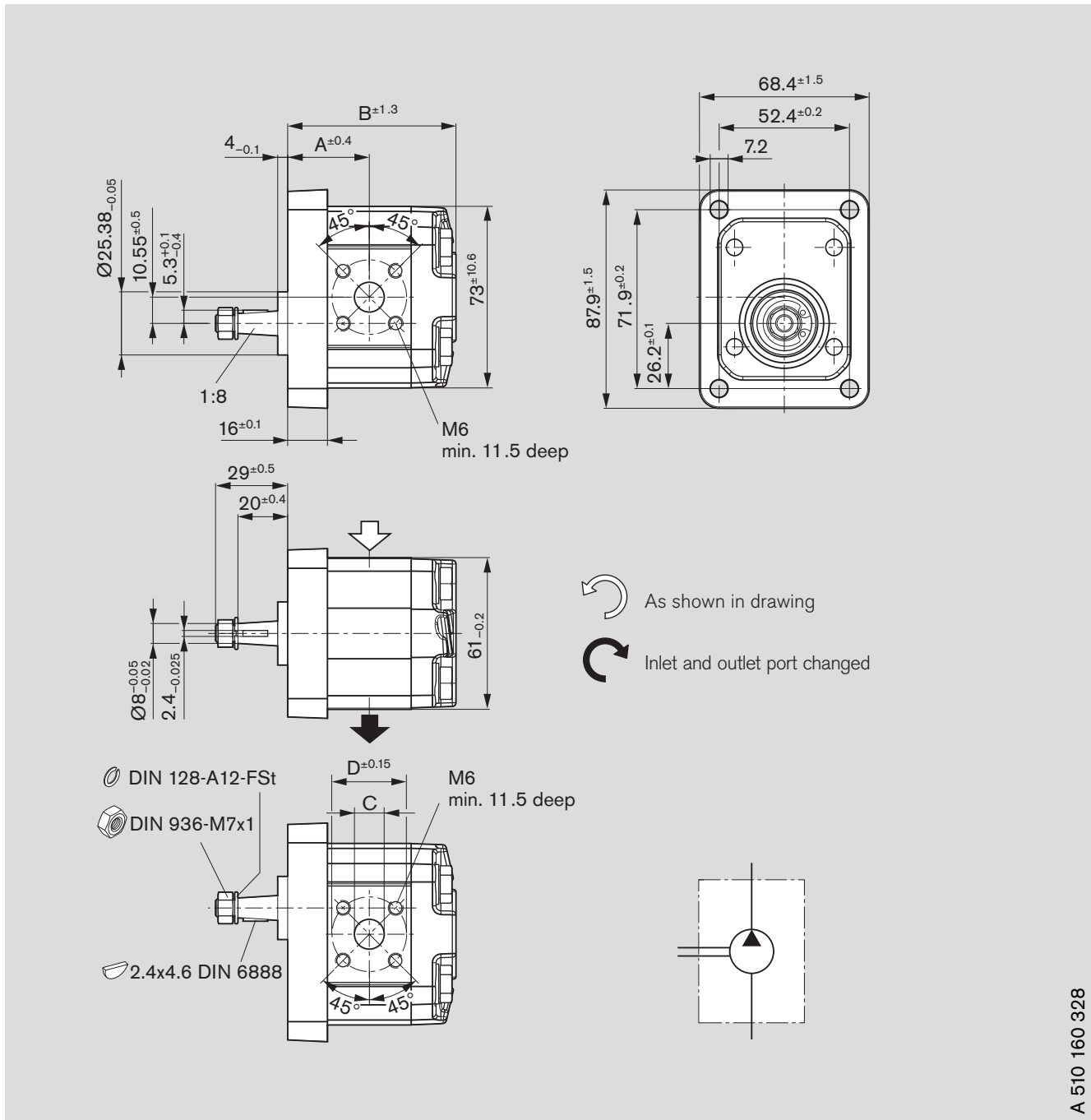

A 510 160 328

Ordering code:

AZPB - 22 - H O 20 M B

Displacement [cm ³ /rev]	Ordering-No.		max. operating pressure [bar]	max. rotation speed [rpm]	Mass kg	Dimension [mm]			
	L	R				A	B	C	D
2	0 510 120 310	0 510 120 012	280	5,000	1.5	32.8	67.9	12	30
2.5	0 510 120 311	0 510 120 013	280	5,000	1.5	33.8	69.8	12	30
3.15	0 510 120 312	0 510 120 014	280	4,000	1.5	35.0	72.3	15	35
4	0 510 120 313	0 510 120 015	280	4,000	1.6	36.6	75.5	15	35
4.5	0 510 120 314	0 510 120 016	280	4,000	1.6	37.8	77.4	15	35
5	0 510 120 315	0 510 120 017	280	4,000	1.6	38.6	79.5	15	35
6.3	0 510 120 316	0 510 120 018	255	3,500	1.7	41.0	84.2	15	35
7.1	0 510 120 317	0 510 120 019	230	3,500	1.7	42.5	87.3	15	35

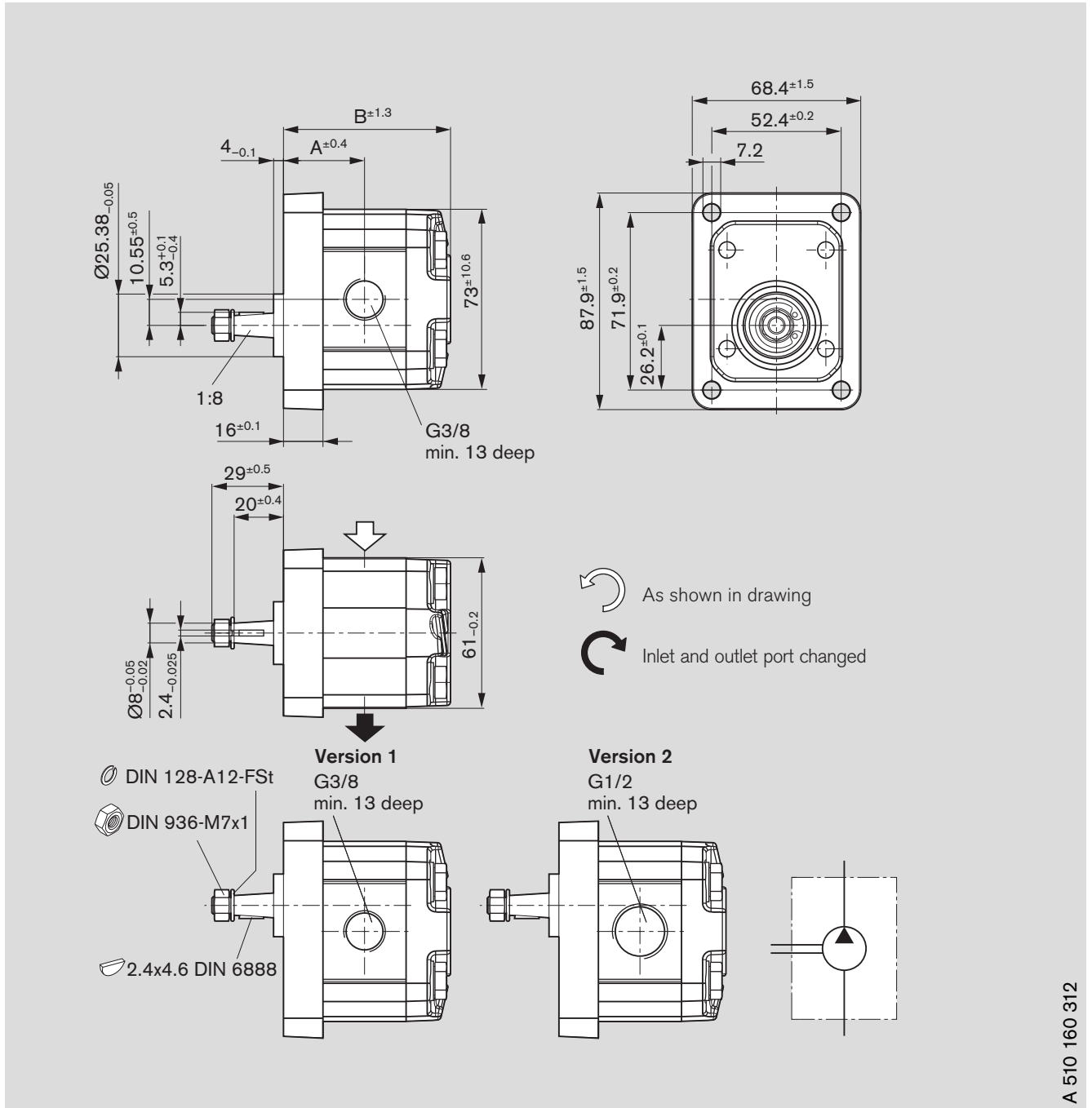

Unit dimensions

Standard range



Ordering code:

AZPB - 22 - H O 01 M B

Displacement [cm ³ /rev]	Ordering-No.		max. operating pressure [bar]	max. rotation speed [rpm]	Mass kg	Dimension [mm]		
	 L	 R				A	B	Version
1	0 510 020 302	0 510 020 002	280	6,000	1.4	30.9	64.1	1
2	0 510 120 302	0 510 120 004	280	5,000	1.5	32.8	67.9	1
2.5	0 510 120 303	0 510 120 005	280	5,000	1.5	33.8	69.8	1
3.15	0 510 120 304	0 510 120 006	280	4,000	1.5	35.0	72.3	1
4	0 510 120 305	0 510 120 007	280	4,000	1.6	36.6	75.5	2
4.5	0 510 120 306	0 510 120 008	280	4,000	1.6	37.8	77.4	2
5	0 510 120 307	0 510 120 009	280	4,000	1.6	38.6	79.5	2
6.3	0 510 120 308	0 510 120 010	255	3,500	1.7	41.0	84.2	2
7.1	0 510 120 309	0 510 120 011	230	3,500	1.7	42.5	87.3	2

Unit dimensions

Standard range

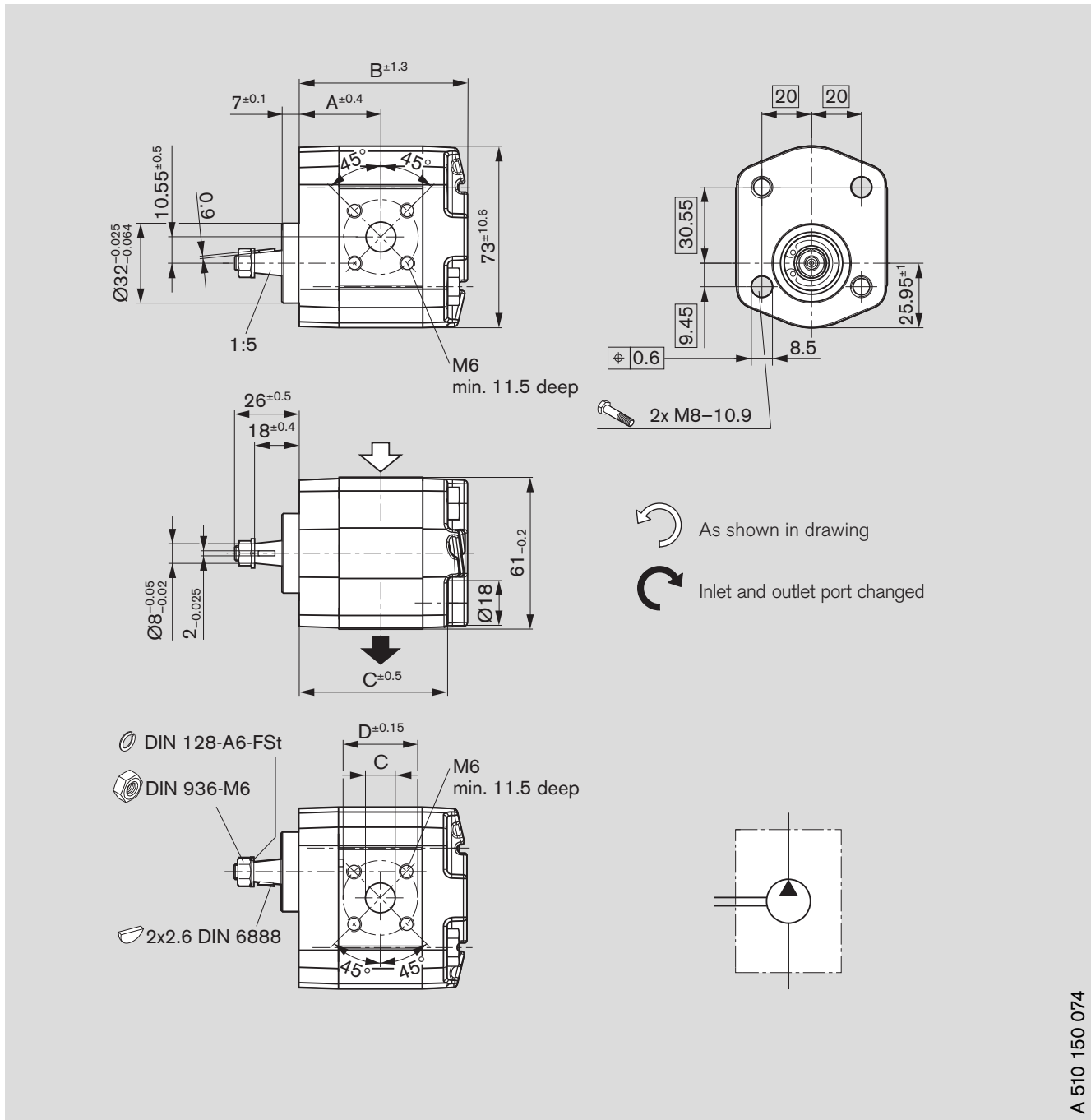

Ordering code:

AZPB - 22 - **C P 20 M B**

Displacement [cm³/rev]	Ordering-No.		max. operating pressure [bar]	max. rotation speed [rpm]	Mass kg	Dimension [mm]				
	L	R				A	B	C	D	E
2	0 510 110 318	0 510 110 012	280	5,000	1.2	32.8	67.9	12	30	59.0
2.5	0 510 110 319	0 510 110 013	280	5,000	1.3	33.8	69.8	12	30	60.9
3.15	0 510 112 314	0 510 112 011	280	4,000	1.3	35.0	72.3	12	30	63.4
4	0 510 114 312	0 510 114 009	280	4,000	1.3	36.6	75.5	15	35	66.6
4.5	0 510 114 313	0 510 114 010	280	4,000	1.4	37.8	77.4	15	35	68.5
5	0 510 114 314	0 510 114 011	280	4,000	1.4	38.6	79.5	15	35	70.6
6.3	0 510 122 308	0 510 122 006	255	3,500	1.4	41.0	84.2	15	35	75.3
7.1	0 510 122 309	0 510 122 007	230	3,500	1.5	42.5	87.3	15	35	78.4

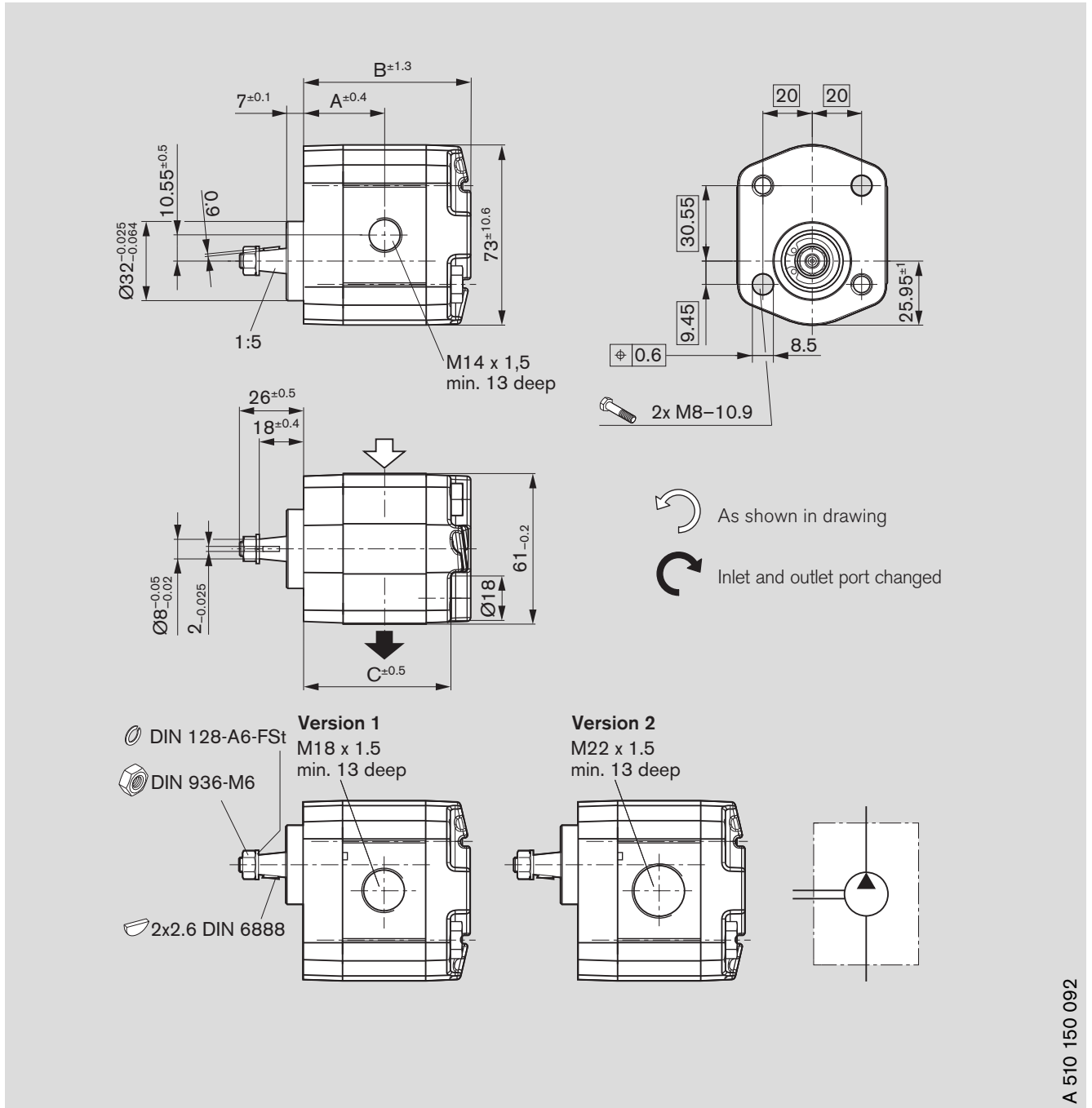

Unit dimensions

Standard range



Ordering code:

AZPB - 22 - C P 02 M B

Displacement [cm ³ /rev]	Ordering-No.		max. operating pressure [bar]	max. rotation speed [rpm]	Mass kg	Dimension [mm]			Version
	 L	 R				A	B	C	
1	0 510 010 309	0 510 010 006	280	6,000	1.2	30.9	64.1	56.4	1
2	0 510 110 314	0 510 110 008	280	5,000	1.2	32.8	67.9	59.0	1
2.5	0 510 110 315	0 510 110 009	280	5,000	1.3	33.8	69.8	60.9	1
3.15	0 510 112 313	0 510 112 010	280	4,000	1.3	35.0	72.3	63.4	1
4	0 510 114 309	0 510 114 006	280	4,000	1.3	36.6	75.5	66.5	2
4.5	0 510 114 310	0 510 114 007	280	4,000	1.4	37.8	77.4	68.5	2
5	0 510 114 311	0 510 114 008	280	4,000	1.4	38.6	79.5	70.6	2
6.3	0 510 122 306	0 510 122 004	255	3,500	1.4	41.0	84.2	75.3	2
7.1	0 510 122 307	0 510 122 005	230	3,500	1.5	42.5	87.3	78.4	2

Unit dimensions

Standard range

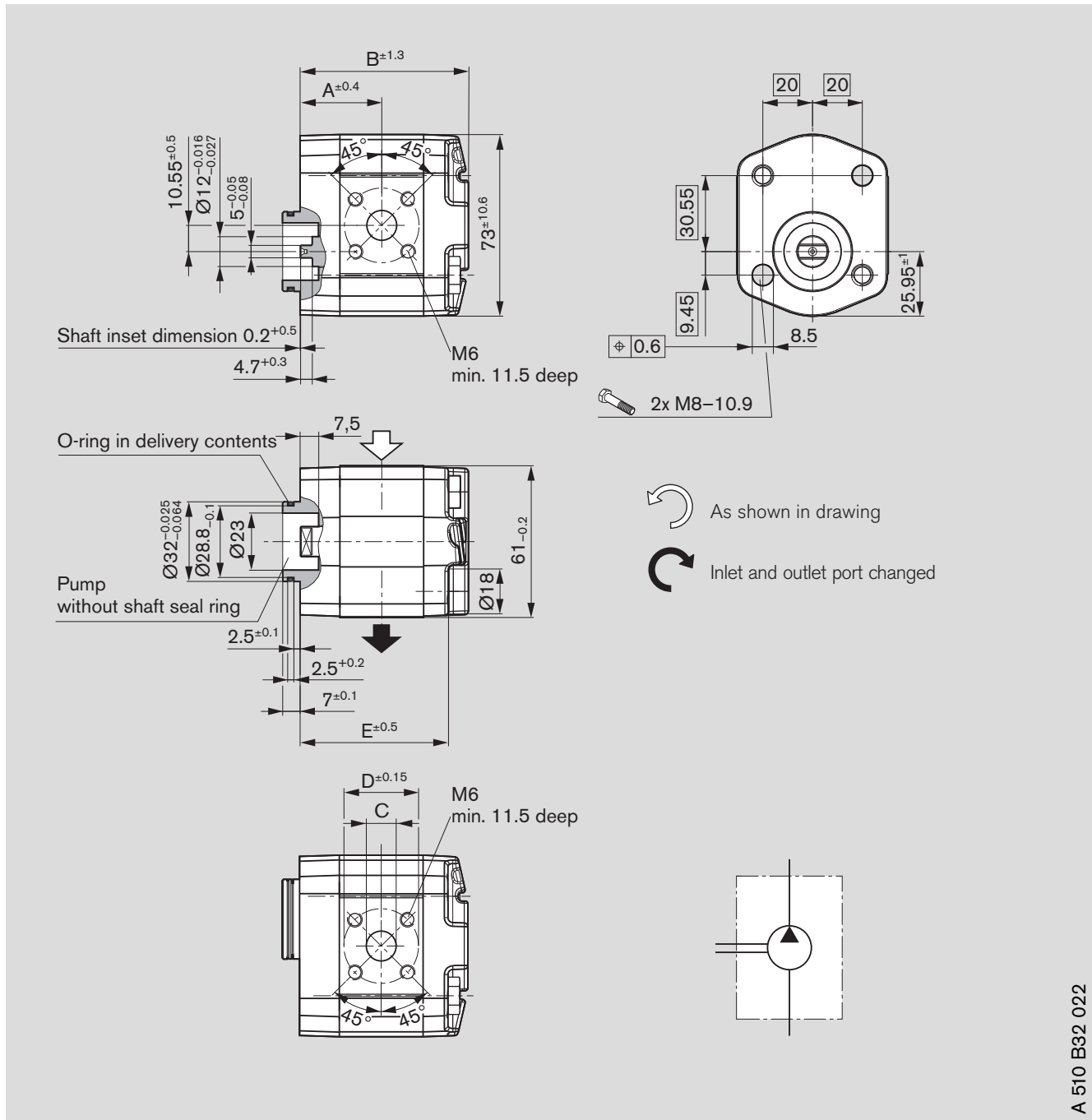

A 510 B32 022

Ordering code:

AZPB - 22 - **N M 20 M B**

Displacement [cm³/rev]	Ordering-No.		max. operating pressure [bar]	max. rotation speed [rpm]	Mass kg	Dimension [mm]				
	L	R				A	B	C	D	E
2	0 510 110 320	0 510 110 015	280	5,000	1.2	32.8	67.9	12	30	59.0
2.5	0 510 110 321	0 510 110 016	280	5,000	1.3	33.8	69.8	12	30	60.9
3.15	0 510 112 316	0 510 112 013	280	4,000	1.3	35.0	72.3	15	35	63.4
4	0 510 114 318	0 510 114 015	280	4,000	1.3	36.6	75.5	15	35	66.6
4.5	0 510 114 319	0 510 114 016	280	4,000	1.3	37.8	77.4	15	35	68.5
5	0 510 114 320	0 510 114 017	280	4,000	1.4	38.6	79.5	15	35	70.6
6.3	0 510 122 312	0 510 122 010	255	3,500	1.4	41.0	84.2	15	35	75.3
7.1	0 510 122 313	0 510 122 011	230	3,500	1.5	42.5	87.3	15	35	78.4

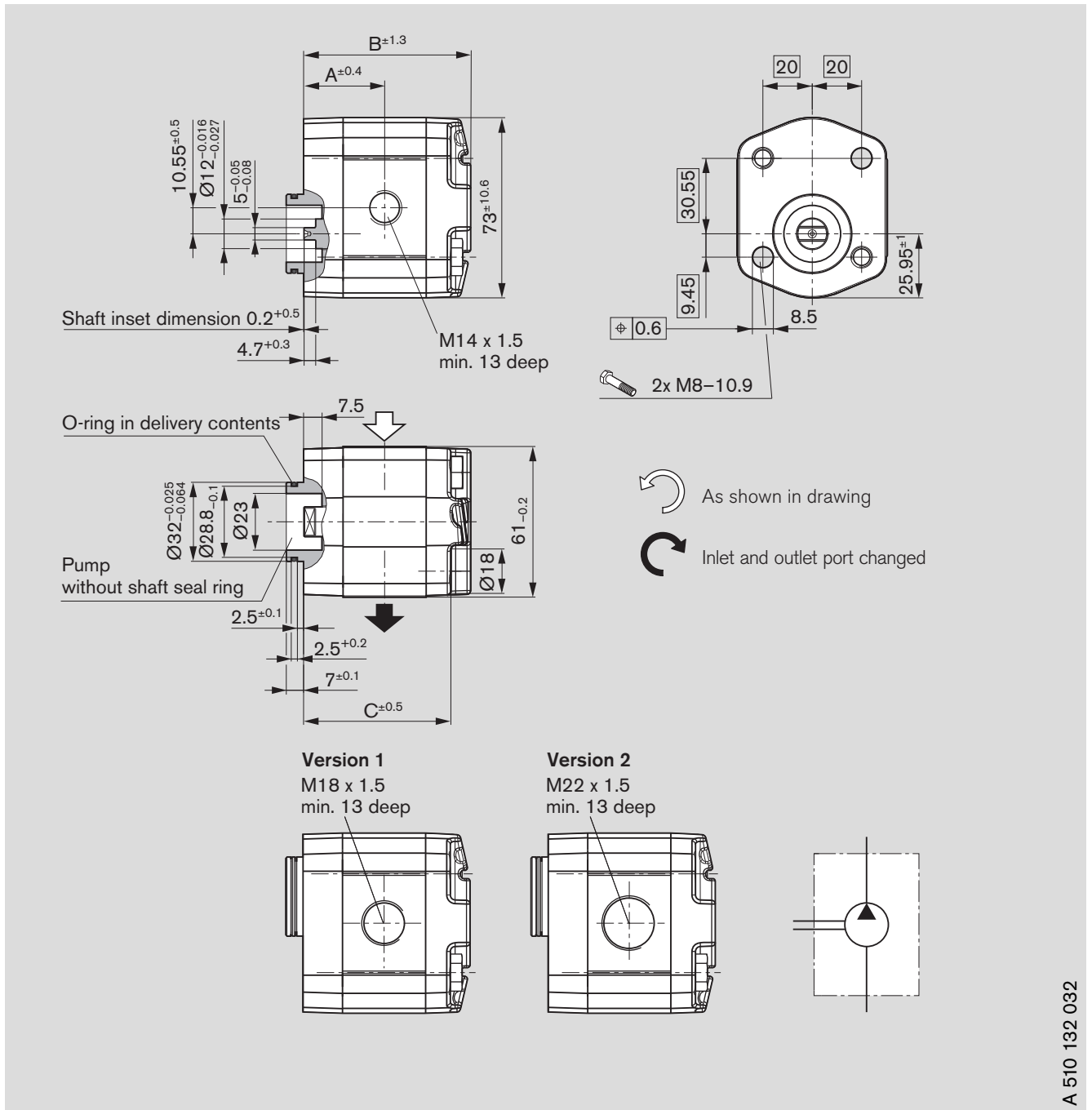

Unit dimensions

Standard range



Ordering code:

AZPB - 22 - C P 02 M B

Displacement [cm ³ /rev]	Ordering-No.		max. operating pressure [bar]	max. rotation speed [rpm]	Mass kg	Dimension [mm]			Version
	 L	 R				A	B	C	
1	0 510 010 310	0 510 010 007	280	6,000	1.2	30.9	64.1	55.2	1
2	0 510 110 316	0 510 110 010	280	5,000	1.2	32.8	67.9	59.0	1
2.5	0 510 110 317	0 510 110 011	280	5,000	1.3	33.8	69.8	60.9	1
3.15	0 510 112 315	0 510 112 012	280	4,000	1.3	35.0	72.3	63.4	1
4	0 510 114 315	0 510 114 012	280	4,000	1.3	36.6	75.5	66.6	2
4.5	0 510 114 316	0 510 114 013	280	4,000	1.3	37.8	77.4	68.5	2
5	0 510 114 317	0 510 114 014	280	4,000	1.4	38.6	79.5	70.6	2
6.3	0 510 122 310	0 510 122 008	255	3,500	1.4	41.0	84.2	75.3	2
7.1	0 510 122 311	0 510 122 009	230	3,500	1.5	42.5	87.3	78.4	2

Unit dimensions

Standard range

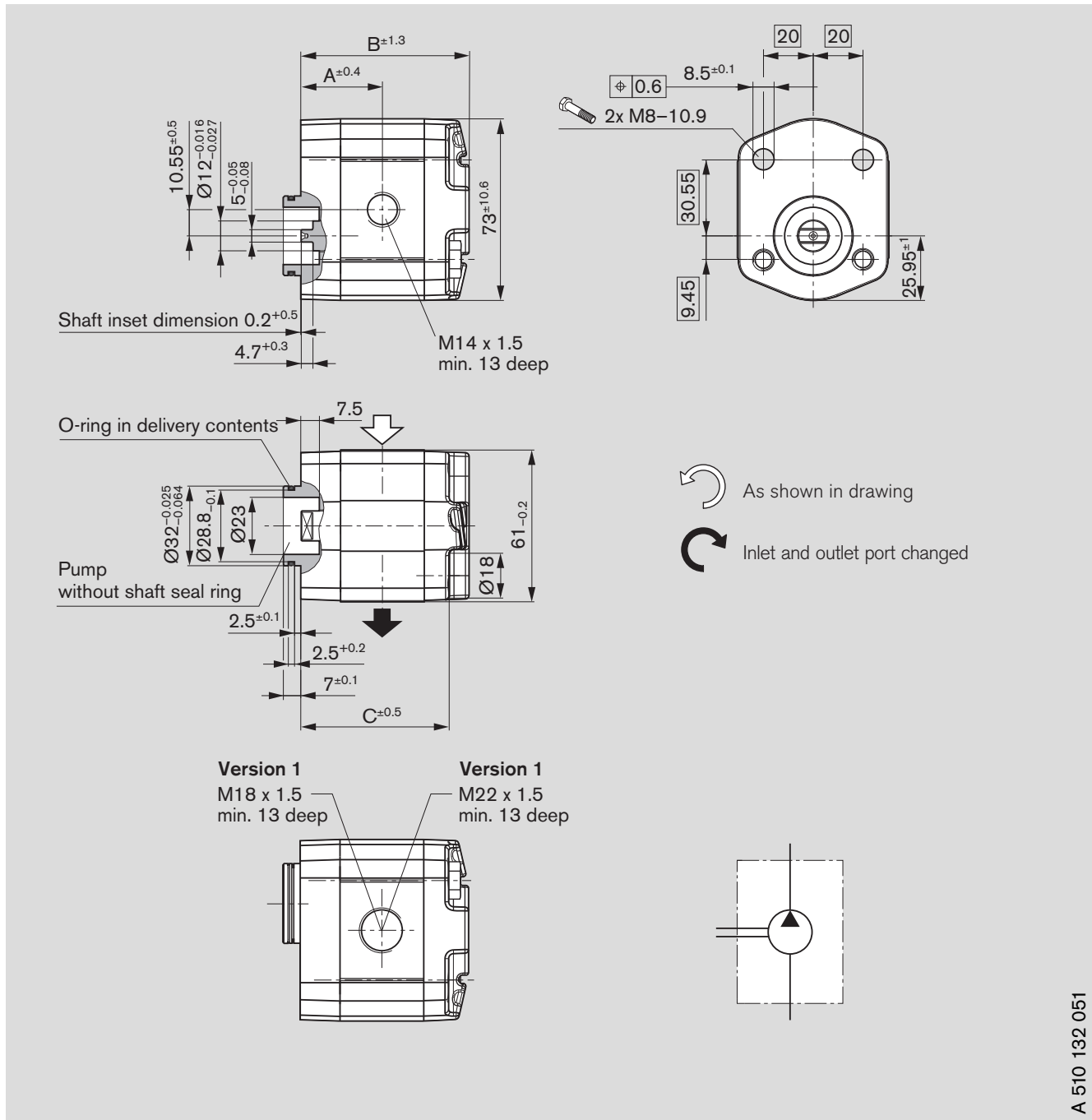

A 510 132 051

Ordering code:

AZPB - 22 - **NY 02 MB**

Displacement [cm ³ /rev]	Ordering-No.		max. operating pressure [bar]	max. rotation speed [rpm]	Mass kg	Dimension [mm]		
	L	R				A	B	Version
1	1 519 222 214	1 519 222 213	280	6,000	1.2	30.9	64.1	1
2	1 519 222 216	1 519 222 215	280	5,000	1.2	32.8	67.9	1
2.5	1 519 222 218	1 519 222 217	280	5,000	1.3	33.8	69.8	1
3.15	1 519 222 220	1 519 222 219	280	4,000	1.3	35.0	72.3	1
4	1 519 222 222	1 519 222 221	280	4,000	1.3	36.6	75.5	2
4.5	1 519 222 224	1 519 222 223	280	4,000	1.4	37.8	77.4	2
5	1 519 222 226	1 519 222 225	280	4,000	1.4	38.6	79.5	2
6.3	1 519 222 228	1 519 222 227	255	3,500	1.4	41.0	84.2	2
7.1	1 519 222 230	1 519 222 229	230	3,500	1.5	42.5	87.3	2

Fittings

Gear pump flange, straight, for rectangular flange **20** see page 7

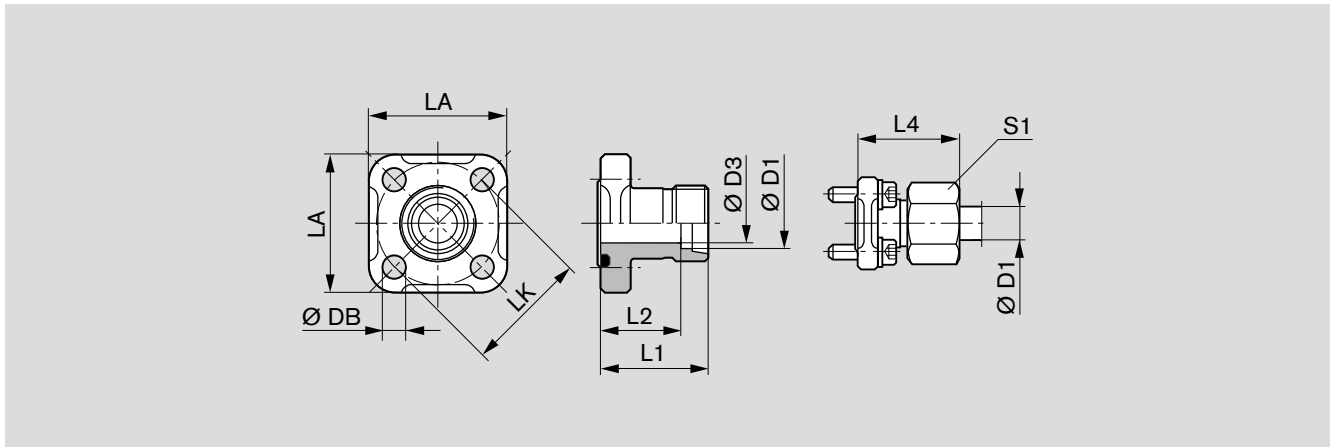

LK	D1	D3	L1	L2	L4	LA	S1	DB	Screws (metr.) 4 pieces	Seal ring	Mass kg	Part number	p (bar)
35	10L	8	30	23.0	39.0	40	19	6.4	M6x22	20x2.5	0.09	1 515 702 064	315
35	12L	10	30	23.0	39.0	40	22	6.4	M6x22	20x2.5	0.10	1 515 702 065	315
35	15L	12	30	23.0	38.0	40	27	6.4	M6x22	20x2.5	0.10	1 515 702 066	250

Complete fittings with seal ring, metric screw set, nuts and olive.

Gear pump flange, 90° angle, for rectangular flange **20** see page 7

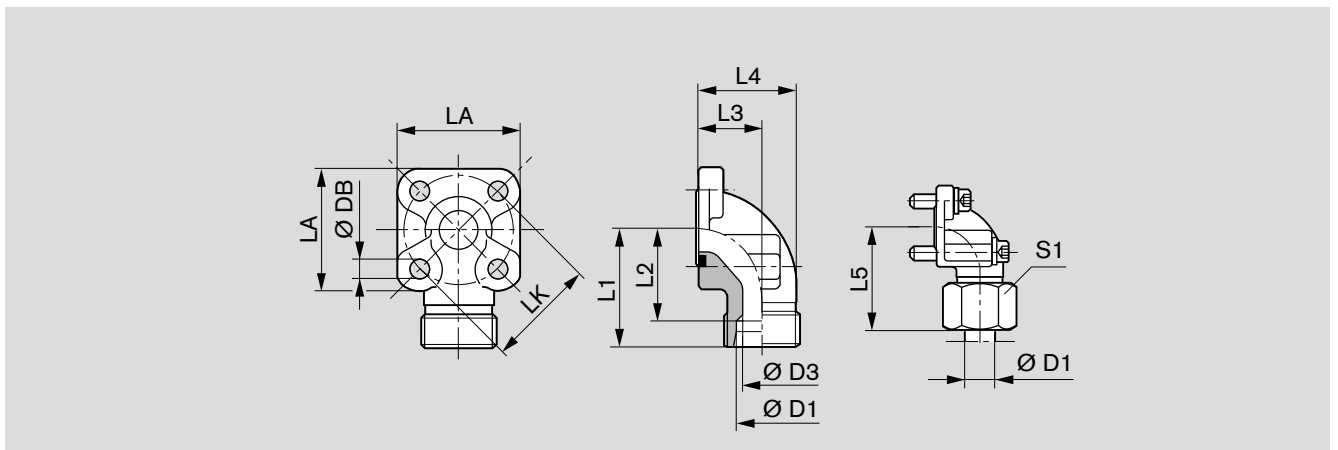

LK	D1	D3	L1	L2	L3	L4	L5	LA	S1	DB	Screws 2 pieces	2 pieces	Seal ring	Mass kg	Part number	p (bar)
35	10L	8	38	31.0	16.5	26.5	47.0	40	19	6.4	M6x22	M6x35	20x2.5	0.16	1 515 702 070	315
35	12L	10	38	31.0	16.5	26.5	47.0	40	22	6.4	M6x22	M6x35	20x2.5	0.16	1 515 702 071	315
35	15L	12	38	31.0	16.5	26.5	46.0	40	27	6.4	M6x22	M6x35	20x2.5	0.15	1 515 702 072	250
35	16S	12	38	29.5	20.0	31.0	48.0	40	30	6.4	M6x22	M6x40	20x2.5	0.18	1 515 702 002	315
35	18L	15	38	29.5	20.0	31.0	47.0	40	32	6.4	M6x22	M6x40	20x2.5	0.18	1 545 702 006	250
35	20S	16	45	34.5	25.0	38.0	56.0	40	36	6.4	M6x22	M6x45	20x2.5	0.24	1 515 702 017	315

Complete fittings with seal ring, metric screw set, nuts and olive.

Notes for commissioning

Filter recommendation

The major share of premature failures in external gear pumps is caused by contaminated pressure fluid.

As a warranty cannot be issued for dirt-specific wear, we recommend filtration compliant with cleanliness level 20/18/15 ISO 4406, which reduces the degree of contamination to a permissible dimension in terms of the size and concentration of dirt particles.

We recommend that a full-flow filter always be used. Basic contamination of the pressure fluid used may not exceed class 20/18/15 according to ISO 4406. Experience has shown that new fluid quite often lies above this value. In such instances a filling device with special filter should be used.

General

- The pumps supplied by us have been checked for function and performance. No modifications of any kind may be made to the pumps; any such changes will render the warranty null and void!
- Pump may only be operated in compliance with permitted data (see pages 15 – 18).

Project planning notes

Comprehensive notes and suggestions are available in Hydraulics Trainer, Volume 3 RE 00 281, "Project planning notes and design of hydraulic systems". Where external gear pumps are used we recommend that the following note be adhered to.

Technical data

All stated technical data is dependent on production tolerances and is valid for specific marginal conditions.

Note that, as a consequence, scattering is possible, and at certain marginal conditions (e.g. viscosity) **the technical data may change.**

Characteristics

When designing the external gear pump, note the maximum possible service data based on the characteristics displayed on pages 13 to 15.

Additional information on the proper handling of hydraulic products from Bosch Rexroth is available in our document: "General product information for hydraulic products" RE 07 008.

Contained in delivery

The components with characteristics as described under device measurements and ordering code, pages 19 – 27, are contained in delivery.

You can find further information in our publication:
"General Operating Instructions for External Gear Units"
RE 07 012-B1.

Spare parts, schematic diagram

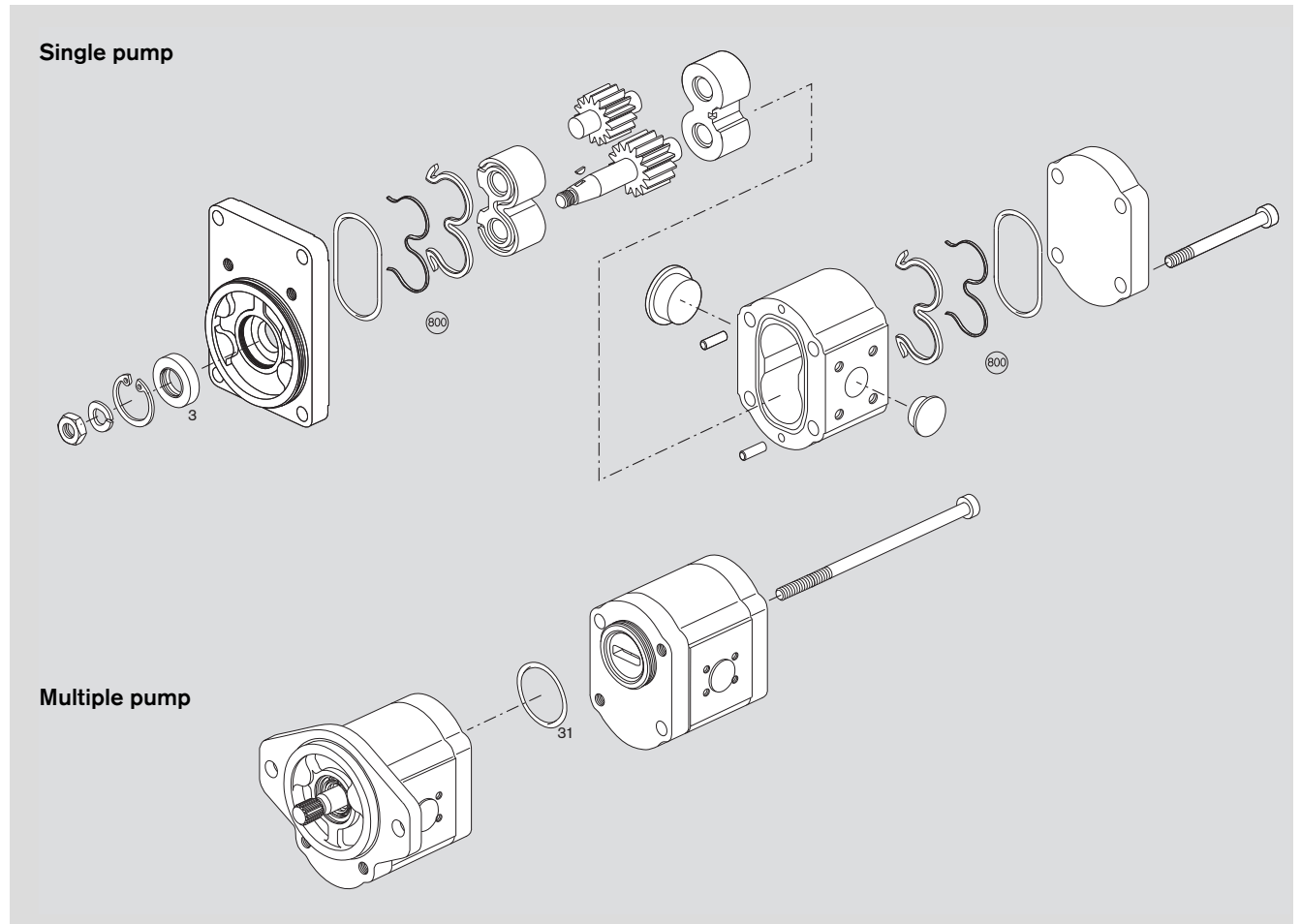

Page	Ordering code	Seal kit "B" Item 800 NBR	Shaft seal ring Item 3	Dimension	Material
16	AZPB - 22 - <input type="checkbox"/> <input type="checkbox"/> <input type="checkbox"/> H O 20 M B	1 517 010 238	1 510 283 074	22x 12x 6	NBR
17	AZPB - 22 - <input type="checkbox"/> <input type="checkbox"/> <input type="checkbox"/> H O 01 M B	1 517 010 238	1 510 283 074	22x 12x 6	NBR
18	AZPB - 22 - <input type="checkbox"/> <input type="checkbox"/> <input type="checkbox"/> C P 20 M B	1 517 010 238	1 510 283 074	22x 12x 6	NBR
19	AZPB - 22 - <input type="checkbox"/> <input type="checkbox"/> <input type="checkbox"/> C P 02 M B	1 517 010 238	1 510 283 074	22x 12x 6	NBR
20	AZPB - 22 - <input type="checkbox"/> <input type="checkbox"/> <input type="checkbox"/> N M 20 M B	1 517 010 238	1 510 283 074	22x 12x 6	NBR
21	AZPB - 22 - <input type="checkbox"/> <input type="checkbox"/> <input type="checkbox"/> N M 02 M B	1 517 010 238	1 510 283 074	22x 12x 6	NBR
22	AZPB - 22 - <input type="checkbox"/> <input type="checkbox"/> <input type="checkbox"/> N Y 02 M B	1 517 010 238	1 510 283 074	22x 12x 6	NBR

NBR = Perbunan®

For multiple pumps

Seal ring Item 31 NBR	1 900 210 127
-----------------------------	---------------

The AZ configurator at www.boschrexroth.com/azconfigurator

The AZ configurator assists you to configure your individual external gear unit easily and user-friendly. You only need to specify your requirements: From the displacement, direction of rotation, drive shaft, connection flange right up to the required rear cover. You immediately receive a project drawing (PDF format) if a configuration already exists. You receive the price of the configured external gear unit upon request.

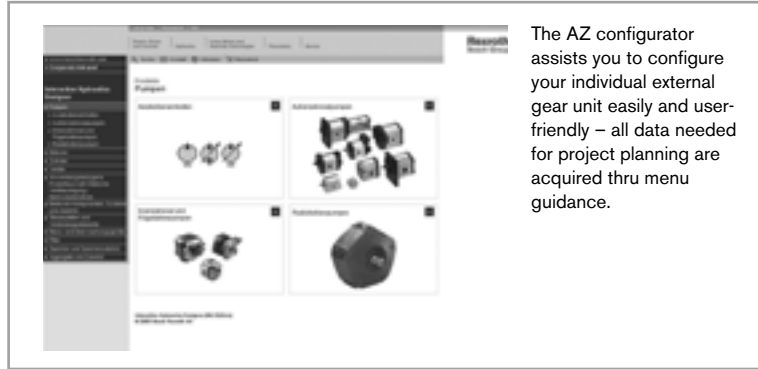

The AZ configurator assists you to configure your individual external gear unit easily and user-friendly – all data needed for project planning are acquired thru menu guidance.

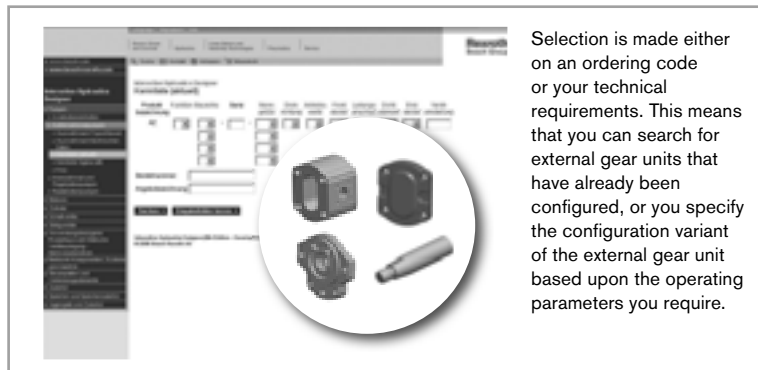

Selection is made either on an ordering code or your technical requirements. This means that you can search for external gear units that have already been configured, or you specify the configuration variant of the external gear unit based upon the operating parameters you require.

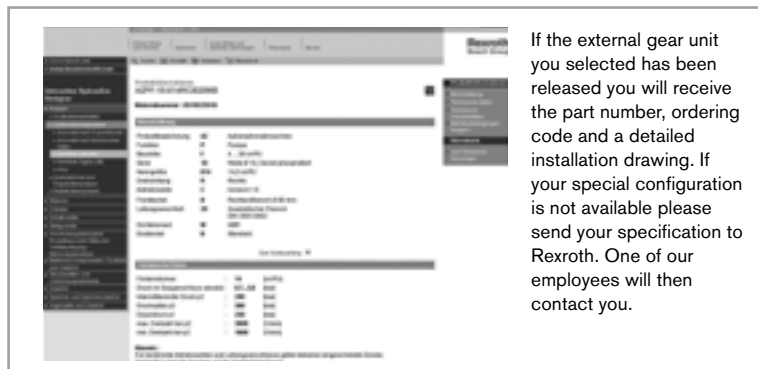

If the external gear unit you selected has been released you will receive the part number, ordering code and a detailed installation drawing. If your special configuration is not available please send your specification to Rexroth. One of our employees will then contact you.