

# Fixed displacement vane pumps

**RE 10335/10.05**  
Replaces: 11.02

1/22

## Types PVV and PVQ

Nominal sizes 18 to 193  
 Series 1X  
 Maximum operating pressure 210 bar  
 Maximum displacement 18 to 193 cm<sup>3</sup>

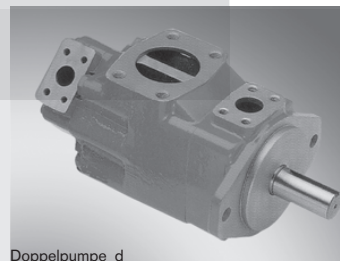

Doppelpumpe\_d\_

Double pump  
 Type PVV21-1X/...A15DD..



H/A/D5769/97

Single pump  
 Type PVV2-1X/...A15D..

## Overview of contents

### Contents

Contents	Page
Features	1
Function, section	2; 3
Symbols	3
Ordering details	4; 5
Technical data	6; 7
Tightening torque, noise pressure level	8
Drive power	9
Flow, flow losses	10
Unit dimensions:	
• PVV / PVQ 1	11
• PVV / PVQ 2; 4; 5	12
• PVV / PVQ 2...K..	13
• PVV / PVQ 4...K..	14
• PVV / PVQ 5...K..	15
• PVV / PVQ 21; 41; 42; 51; 52	16
• PVV / PVQ 54	17
Drive shaft BS 2 to 54	18
Pump cartridge	19
Accessories	20
Engineering and commissioning guidelines	21
Installation guidelines	22

## Features

- Fixed displacement
  - Long bearing life due to hydraulically unloaded shaft
  - Low wear due hydraulically unloaded vanes
  - Low operating noise
  - Easy to service due to exchangeable pump cartridges
  - Good efficiency
  - Optional positioning of the pressure connection
  - Clockwise or anti-clockwise direction of rotation
  - Drive shaft optionally; cylindrical or splined
- Double pump:
- Very compact design
  - The position of the pressure connections can be individually selected

For information regarding the available spare parts see:  
[www.boschrexroth.com/spc](http://www.boschrexroth.com/spc)

## Function, section

The PVV and PVQ hydraulic pumps are fixed displacement vane pumps.

The rotor (2) is fitted onto the splines of the drive shaft (1) which rotates inside the stator ring (3). The vanes (4) are fitted into slots in the rotor and are pressed onto the inner surface of the stator ring by centrifugal force as the rotor turns. The displacement chambers are sealed on the sides by the control plates (5). Due to the double extentric form of the stator ring there are two pressure and two suction chambers opposite to each other. The drive shaft is thereby hydraulically unloaded. It

only has to carry the torque forces. The vanes are partially unloaded as they pass through the suction areas. This unloading results in reduction in wear and makes it possible to obtain a high efficiency.

By simply removing the cover (6) it is possible to remove the pump cartridge (comprising of rotor, vanes, stator ring and control plates) without having to remove the housing (7) from the pump mounting bracket. This makes it possible to quickly repair and maintain the pump.

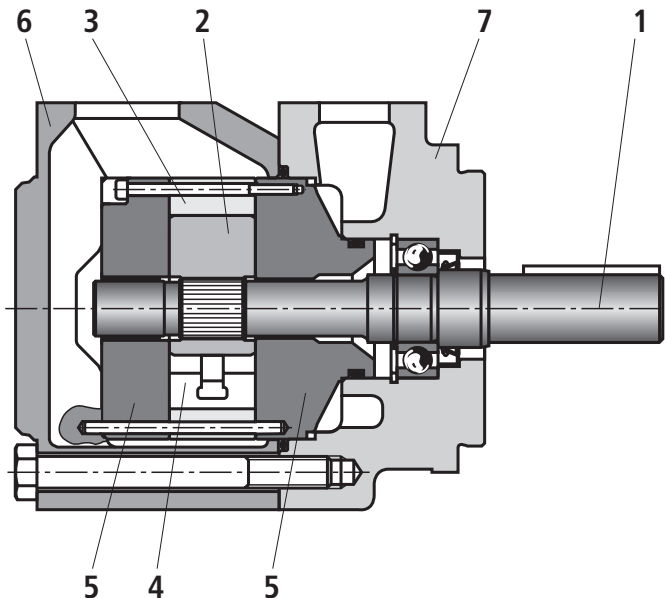
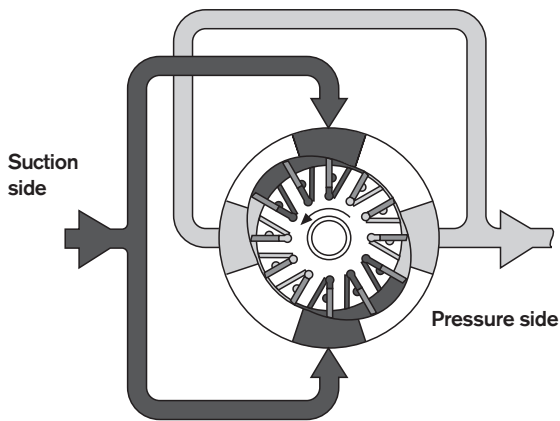

Type PVV..-1X/...A15D...

The design of the type PVQ pump makes it particularly suitable for mobile applications.

The special design of the control plates makes it possible to compensate for the heat expansion of the rotor and to act against sudden pressure changes. Due to the division of the control plates (7) into flexible discs and the cover plates (8),

counter pressure chambers (9) are created that are balanced against the pressures that are in the displacement chambers. Due to this, the optimum clearance between the rotor and the flexible discs is guaranteed and thus the best volumetric efficiency is made possible.

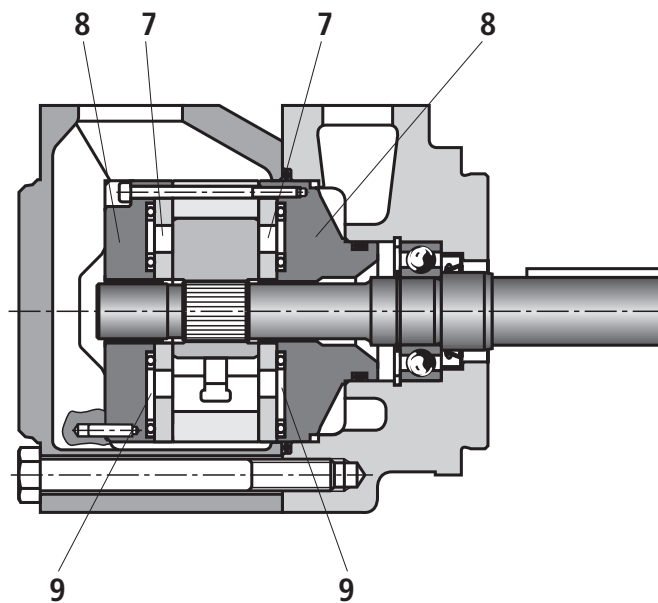

Type PVQ..1X/...A15D...

## Function, section

The PVV and PVQ double pumps are created by fitting a second pump cartridge onto a mutual shaft. The oil inlet is via a common suction connection in the centre housing (10). The oil outputs is separate via the pump cartridge. The pressure connection for the front pump cartridge is in the flange housing and for the rear pump cartridge in the cover plate.

The largest pump cartridge is always fitted at the flange housing end. It is not possible to have identically sized pump cartridges as a double pump.

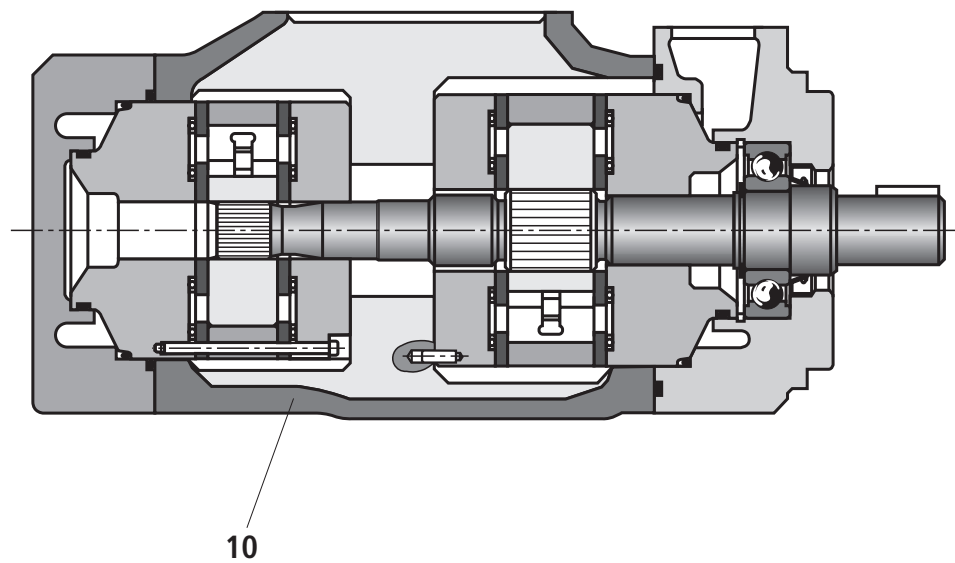

## Symbols

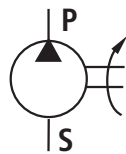

Single pump

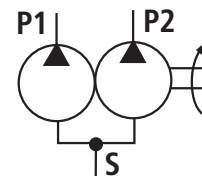

Double pump



## Ordering details (build size, displacement flows)

Single pumps	
Build size	Displacement flows
1	18,0 cm <sup>3</sup> = <b>018</b>
	27,4 cm <sup>3</sup> = <b>027</b>
	36,4 cm <sup>3</sup> = <b>036</b>
	39,5 cm <sup>3</sup> = <b>040</b>
	45,9 cm <sup>3</sup> = <b>046</b>
2	40,1 cm <sup>3</sup> = <b>040</b>
	45,4 cm <sup>3</sup> = <b>045</b>
	55,2 cm <sup>3</sup> = <b>055</b>
	60,0 cm <sup>3</sup> = <b>060</b>
	67,5 cm <sup>3</sup> = <b>068</b>
4	69,0 cm <sup>3</sup> = <b>069</b>
	81,6 cm <sup>3</sup> = <b>082</b>
	97,7 cm <sup>3</sup> = <b>098</b>
	112,7 cm <sup>3</sup> = <b>113</b>
	121,6 cm <sup>3</sup> = <b>122</b>
5	138,6 cm <sup>3</sup> = <b>139</b>
	153,5 cm <sup>3</sup> = <b>154</b>
	162,2 cm <sup>3</sup> = <b>162</b>
	183,4 cm <sup>3</sup> = <b>183</b>
	193,4 cm <sup>3</sup> = <b>193</b>

Double pumps		
Build size	Flange side	Cover side
	Displacement flows	
21	40,1 cm <sup>3</sup> = <b>040</b>	18,0 cm <sup>3</sup> = <b>018</b>
	45,4 cm <sup>3</sup> = <b>045</b>	27,4 cm <sup>3</sup> = <b>027</b>
	55,2 cm <sup>3</sup> = <b>055</b>	36,4 cm <sup>3</sup> = <b>036</b>
	60,0 cm <sup>3</sup> = <b>060</b>	39,5 cm <sup>3</sup> = <b>040</b>
	67,5 cm <sup>3</sup> = <b>068</b>	45,9 cm <sup>3</sup> = <b>046</b>
41	69,0 cm <sup>3</sup> = <b>069</b>	18,0 cm <sup>3</sup> = <b>018</b>
	81,6 cm <sup>3</sup> = <b>082</b>	27,4 cm <sup>3</sup> = <b>027</b>
	97,7 cm <sup>3</sup> = <b>098</b>	36,4 cm <sup>3</sup> = <b>036</b>
	112,7 cm <sup>3</sup> = <b>113</b>	39,5 cm <sup>3</sup> = <b>040</b>
	121,6 cm <sup>3</sup> = <b>122</b>	45,9 cm <sup>3</sup> = <b>046</b>
42	69,0 cm <sup>3</sup> = <b>069</b>	40,1 cm <sup>3</sup> = <b>040</b>
	81,6 cm <sup>3</sup> = <b>082</b>	45,4 cm <sup>3</sup> = <b>045</b>
	97,7 cm <sup>3</sup> = <b>098</b>	55,2 cm <sup>3</sup> = <b>055</b>
	112,7 cm <sup>3</sup> = <b>113</b>	60,0 cm <sup>3</sup> = <b>060</b>
	121,6 cm <sup>3</sup> = <b>122</b>	67,5 cm <sup>3</sup> = <b>068</b>
51	138,6 cm <sup>3</sup> = <b>139</b>	18,0 cm <sup>3</sup> = <b>018</b>
	153,5 cm <sup>3</sup> = <b>154</b>	27,4 cm <sup>3</sup> = <b>027</b>
	162,2 cm <sup>3</sup> = <b>162</b>	36,4 cm <sup>3</sup> = <b>036</b>
	183,4 cm <sup>3</sup> = <b>183</b>	39,5 cm <sup>3</sup> = <b>040</b>
	193,4 cm <sup>3</sup> = <b>193</b>	45,9 cm <sup>3</sup> = <b>046</b>
52	138,6 cm <sup>3</sup> = <b>139</b>	40,1 cm <sup>3</sup> = <b>040</b>
	153,5 cm <sup>3</sup> = <b>154</b>	45,4 cm <sup>3</sup> = <b>045</b>
	162,2 cm <sup>3</sup> = <b>162</b>	55,2 cm <sup>3</sup> = <b>055</b>
	183,4 cm <sup>3</sup> = <b>183</b>	60,0 cm <sup>3</sup> = <b>060</b>
	193,4 cm <sup>3</sup> = <b>193</b>	67,5 cm <sup>3</sup> = <b>068</b>
54	138,6 cm <sup>3</sup> = <b>139</b>	69,0 cm <sup>3</sup> = <b>069</b>
	153,5 cm <sup>3</sup> = <b>154</b>	81,6 cm <sup>3</sup> = <b>082</b>
	162,2 cm <sup>3</sup> = <b>162</b>	97,7 cm <sup>3</sup> = <b>098</b>
	183,4 cm <sup>3</sup> = <b>183</b>	112,7 cm <sup>3</sup> = <b>113</b>
	193,4 cm <sup>3</sup> = <b>193</b>	121,6 cm <sup>3</sup> = <b>122</b>

Single pumps with through drive	
Build size	Displacement flows
2	40,1 cm <sup>3</sup> = <b>040</b>
	45,4 cm <sup>3</sup> = <b>045</b>
	55,2 cm <sup>3</sup> = <b>055</b>
	60,0 cm <sup>3</sup> = <b>060</b>
	67,5 cm <sup>3</sup> = <b>068</b>
4	69,0 cm <sup>3</sup> = <b>069</b>
	81,6 cm <sup>3</sup> = <b>082</b>
	97,7 cm <sup>3</sup> = <b>098</b>
	112,7 cm <sup>3</sup> = <b>113</b>
	121,6 cm <sup>3</sup> = <b>122</b>
5	138,6 cm <sup>3</sup> = <b>139</b>
	153,5 cm <sup>3</sup> = <b>154</b>
	162,2 cm <sup>3</sup> = <b>162</b>
	183,4 cm <sup>3</sup> = <b>183</b>
	193,4 cm <sup>3</sup> = <b>193</b>

**Technical data** (for applications outside these parameters, please consult us!)**General**

Mounting style	Flange mounting to SAE J744													
Pipe connections	SAE flange version (fixing threads: UNC)													
Direction of rotation	Clockwise or anti-clockwise													
Direction of flow	Inlet and outlet are independent of the direction of rotation													
Installation	Optional, inlet connection preferably at the top													
Drive	Direct, co-axial drive; radial and axial forces cannot be taken up													
Weight	BS	1	2	2K	4	4K	5	5K	21	41	42	51	52	54
	kg	12	14,8	19,4	23	28,7	34	38,1	20	34	34,5	43	46	54

**Hydraulic**

Build sizes 1 and 2 (pump cartridge)		BS1					BS2					
Nominal size ( $\approx V$ in cm <sup>3</sup> )	NS	18	27	36	40	46	40	45	55	60	68	
Max. flow at $n = 1500 \text{ min}^{-1}$ , $p = 0,7 \text{ bar}$ and $v = 25 \text{ mm}^2/\text{s}$	$q_v$ l/min	26	39	53	59	70	59	66	80	89	100	
Operating pressure, absolute		When using fluids containing water and phosphate ester min. 0,9 bar										
Inlet	$p_{\text{min-max}}$ bar	0.83 to 2.4 (recommended: 1...1.35)										
Outlet continuous for PVV	$p_{\text{max}}$ bar	210	210	210	160	140	175	175	175	175	175	
Outlet continuous for PVQ	$p_{\text{max}}$ bar	210	210	210	160	140	210	210	210	210	210	
Peak	$p_{\text{max}}$	A max. of 10% continuous output pressure; not longer than 0.5 seconds										
RPM	$n_{\text{min}}$ min <sup>-1</sup>	600					600					
*) At 1 bar	$n_{\text{max}}$ bei PVV min <sup>-1</sup> *)	1800					1800					
Inlet pressure	$n_{\text{max}}$ bei PVQ min <sup>-1</sup> *)	2700					2700		2500			
Min. drive power required at $\Delta p \approx 0 \text{ bar}$ , $n \approx 1.450 \text{ min}^{-1}$	kW	1.1	1.5	2,2			3			4		
Pressure fluid For use with the above stated operating data		HLP mineral oil to DIN 51524 part 2										
Only with FKM seals („V“)	Perm. $p_{\text{max}}$ bar	210	210	210	160	140	175	175	175	175	175	
Phosphate ester (HFD-R)	Perm. $n_{\text{max}}$ min <sup>-1</sup>	1200										
Build sizes 4 and 5 (pump cartridge)		BS4					BS5					
Nominal sizes ( $\approx V$ in cm <sup>3</sup> )	NS	69	82	98	113	122	139	154	162	183	193	
Max. flow at $n = 1500 \text{ min}^{-1}$ , $p = 0,7 \text{ bar}$ and $v = 25 \text{ mm}^2/\text{s}$	$q_v$ l/min	101	120	141	167	177	203	223	234	267	285	
Operating pressure, absolute		When using fluids containing water and phosphate ester min. 0,9 bar										
Inlet	$p_{\text{min-max}}$ bar	0.83 to 2.4 (recommended: 1...1,35)										
Outlet continuous for PVV	$p_{\text{max}}$ bar	175	175	175	175	175	175	175	175	175	175	
Outlet continuous for PVQ	$p_{\text{max}}$ bar	210	210	210	210	210	175	175	175	175	175	
Peak	$p_{\text{max}}$	A max. of 10% continuous output pressure; not longer than 0.5 seconds										
RPM	$n_{\text{min}}$ min <sup>-1</sup>	600					600					
*) At 1 bar	$n_{\text{max}}$ bei PVV min <sup>-1</sup> *)	1800					1800					
Inlet pressure	$n_{\text{max}}$ bei PVV min <sup>-1</sup> *)	2500			2400		2200					
Min. drive power required At $\Delta p \approx 0 \text{ bar}$ , $n \approx 1.450 \text{ min}^{-1}$	kW	4		5.5			7.5			11		

**Technical data** (for applications outside these parameters, please consult us!)

Continuation from page 6

**Hydraulic**

Build sizes 4 and 5 (pump cartridge)			BS4					BS5				
Pressure fluid For use with the operating data shown on page 7			HLP mineral oil DIN 51524 part 2									
Only with FKM seals („V“)	Perm. $p_{max}$	bar	175	175	175	175	175	175	175	175	175	175
Phosphate ester (HFD-R)	Perm. $n_{max}$	min <sup>-1</sup>	1200									
Pressure fluid temperature range		°C	-10 to +70. (recommended: +30 to +60) Take into account the permissible viscosity range									
Viscosity range		mm <sup>2</sup> /s	13 to 860 (recommended: 13 to 54)									
Max. permissible degree of pressure fluid contamination Cleanliness class to ISO 4406 (E) / (c)			Class 20/18/15 <sup>1)</sup>									
Alternative pressure fluids			HFB					HFC				
Max. permissible operating pressure		bar	70					140				
			Only in conjunction with a return filter with a retention rate of $\beta_{10} \geq 100$ or more. The permissible pressure fluid temperature range is +15 °C to +50 °C. Maximum permissible RPM: 1200 min <sup>-1</sup>									

**Please consult us before using our fixed displacement vane pumps with these pressure fluids!**

<sup>1)</sup> The cleanliness class stated for the components must be adhered to in hydraulic systems. Effective filtration prevents faults from occurring and at the same time increases the component service life.

For the selection of filters see data sheets RE 50070, RE 50076, RE 50081, RE 50086 and RE 50088.

**On pages 6 and 7 the stated values for the maximum RPM are valid for an absolute pressure of 1 bar at the inlet.**

The maximum permissible RPM has to be corrected in accordance with the following diagrams in relation to the absolute pressure present at the inlet.

**PVV/PVQ**

**BS1; BS2; BS4; BS21; BS41; BS42**

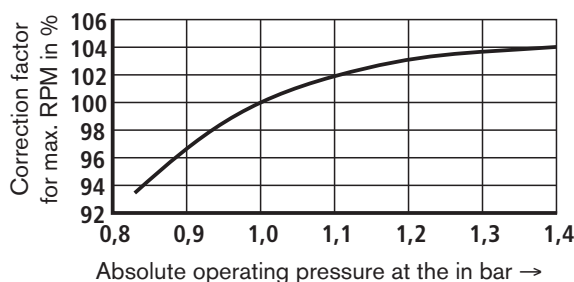

**BS5; BS51; BS52; BS54**

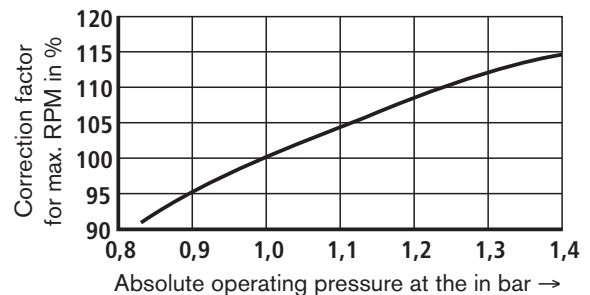

**Drive torque** (measured with  $\nu = 41 \text{ mm}^2/\text{s}$ ;  $\vartheta = 50 \text{ }^\circ\text{C}$ )

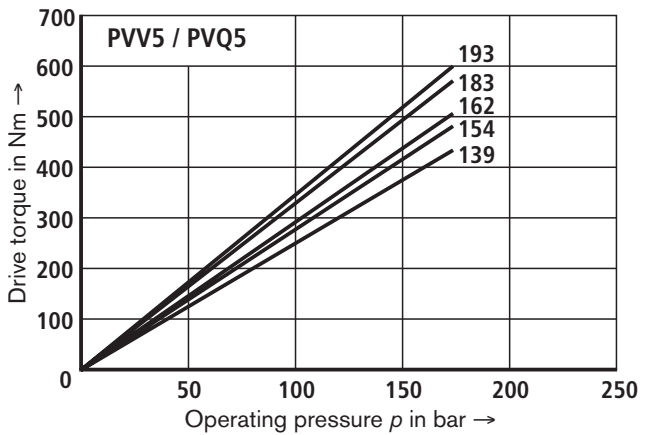
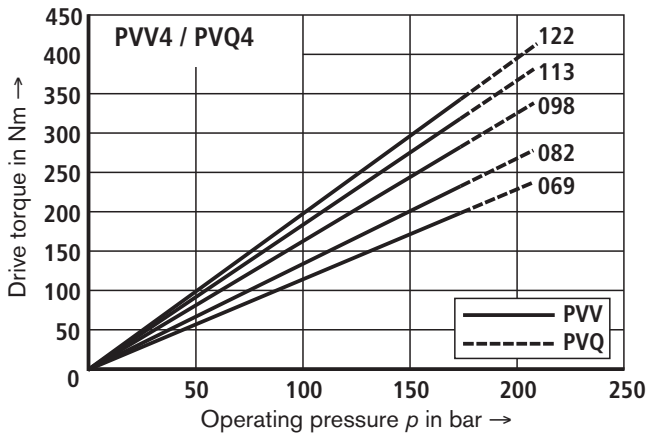
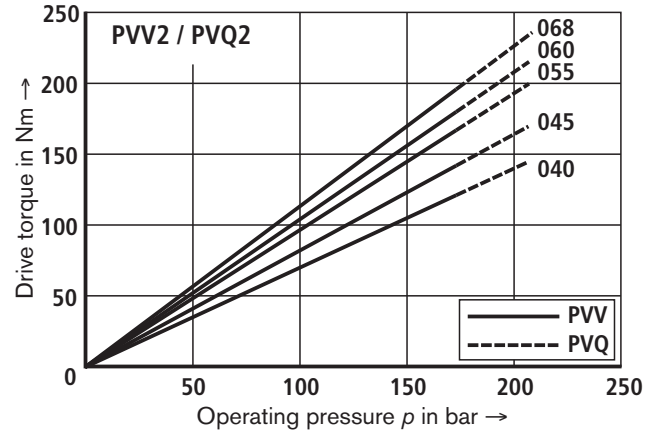
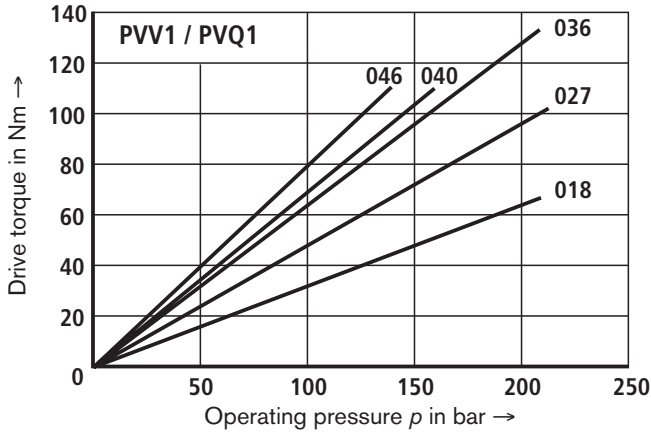

**Noise pressure level** measured in a low noise room to DIN 45635 part 26.

Distance of noise sensor to pump = 1 m.  $\nu = 41 \text{ mm}^2/\text{s}$ ;  $n = 1500$  and  $\vartheta = 50 \text{ }^\circ\text{C}$

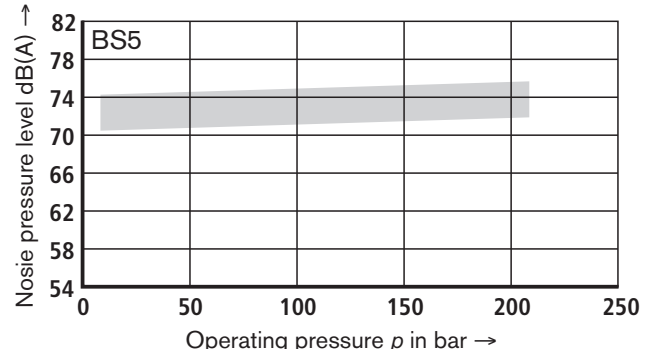
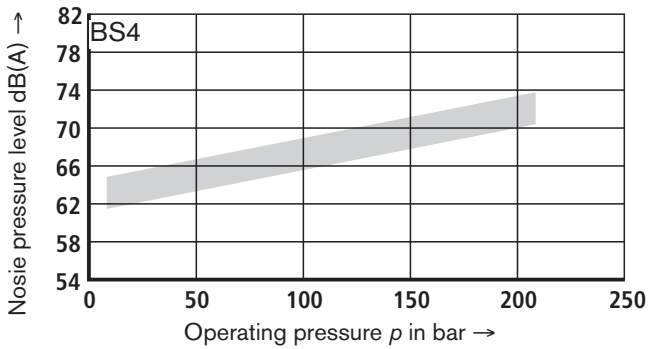
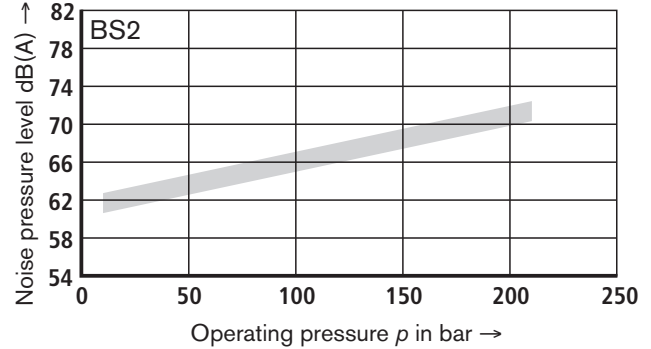
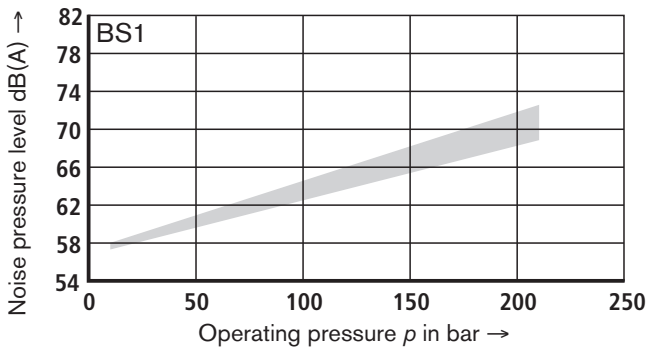

The noise pressure levels for double pumps lie on average 1 to 3 dB(A) above the values for single pumps.

Drive power (measured at  $v = 41 \text{ mm}^2/\text{s}$ ;  $\vartheta = 50 \text{ }^\circ\text{C}$ )

$n = 1500 \text{ min}^{-1}$

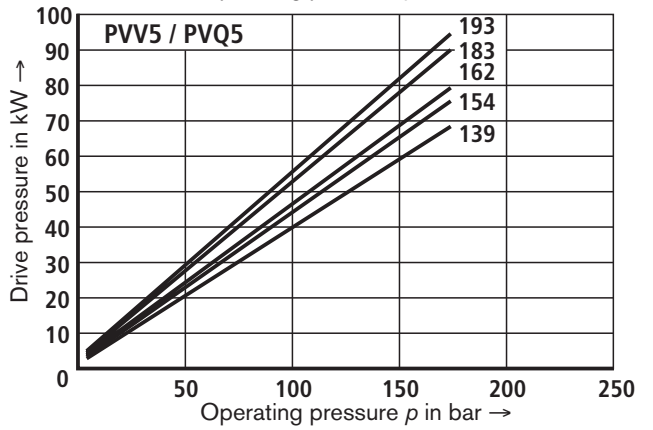
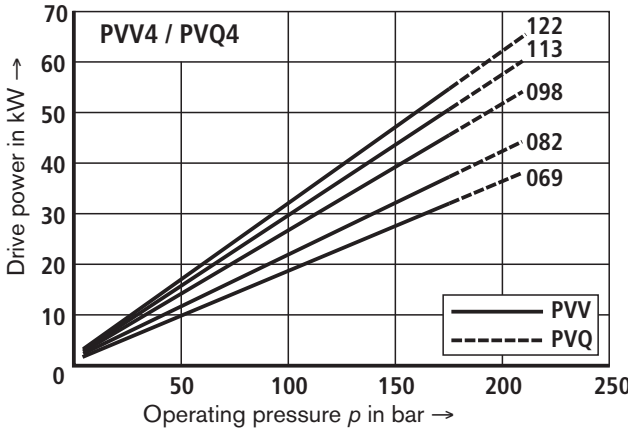
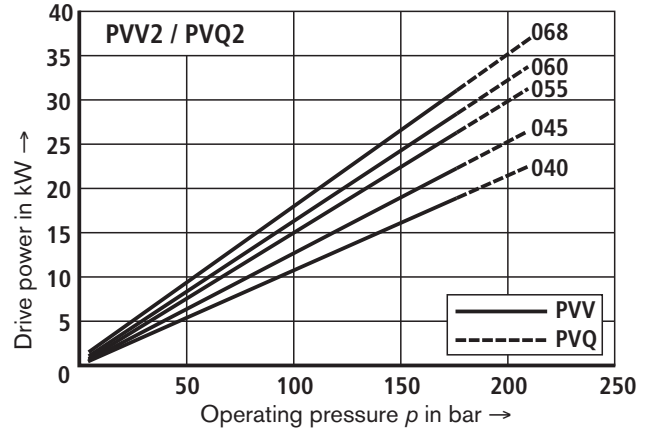
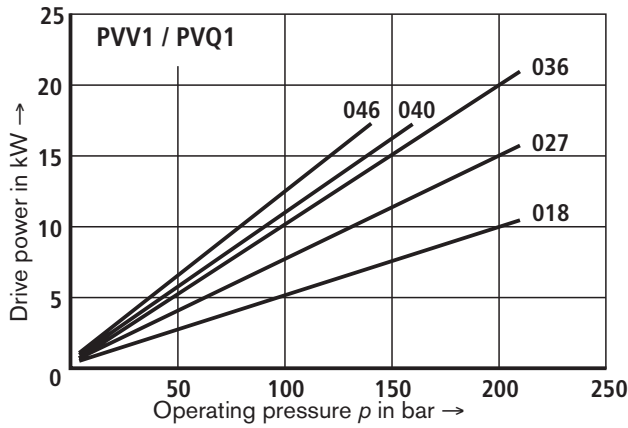

$n = 1800 \text{ min}^{-1}$

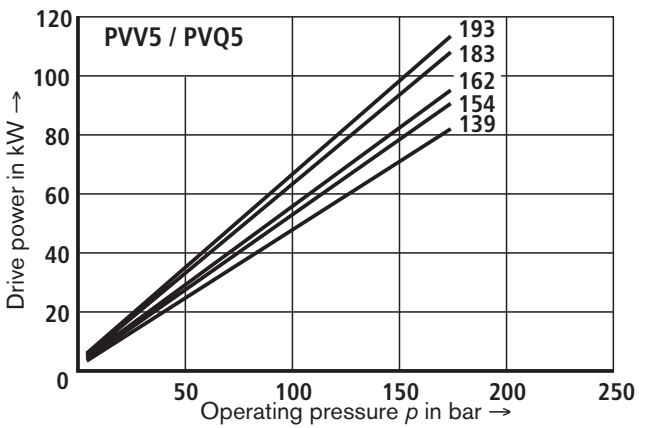
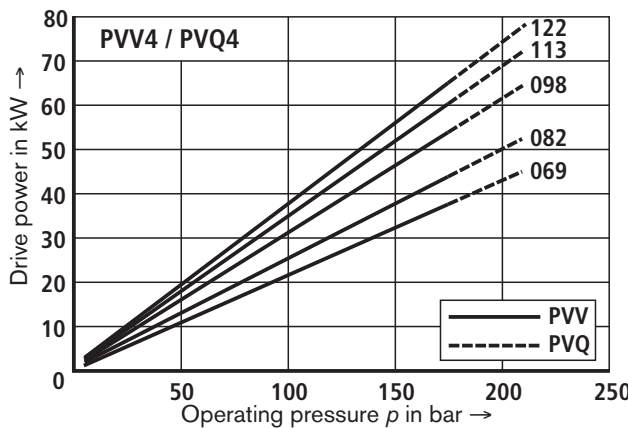
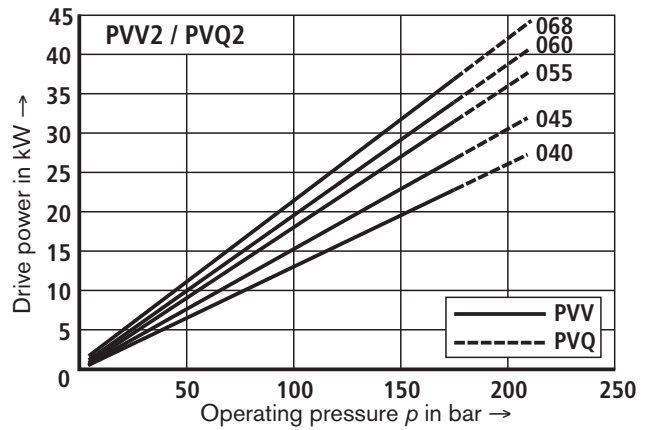
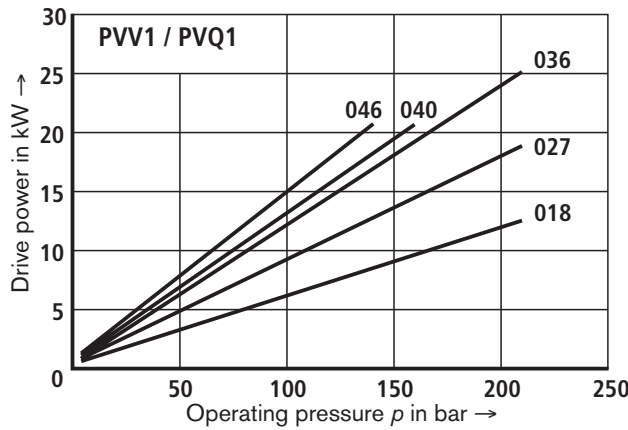

**Flow, speed dependent** (measured at  $v = 41 \text{ mm}^2/\text{s}$ ;  $\vartheta = 50 \text{ }^\circ\text{C}$ ;  $p = 7 \text{ bar}$ )

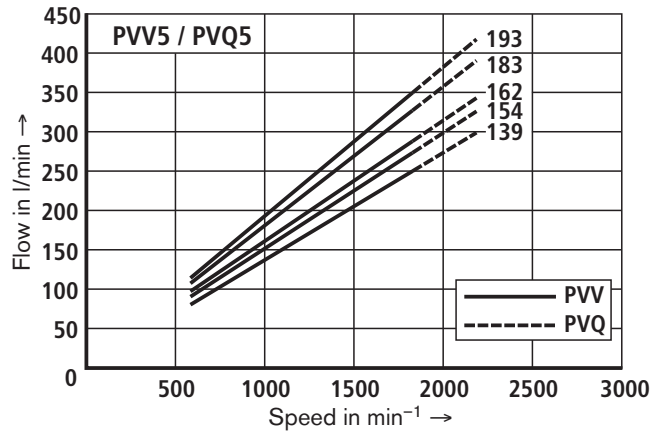
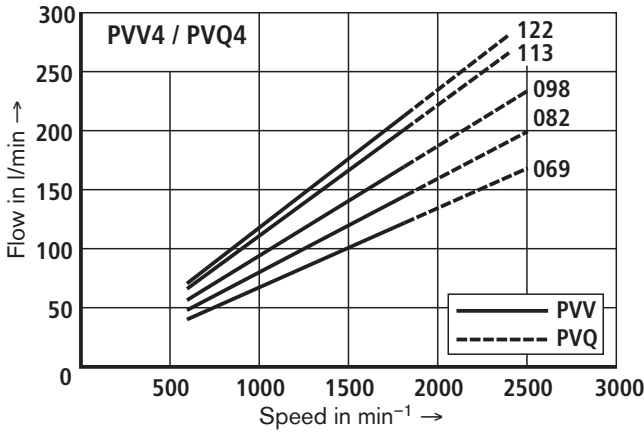
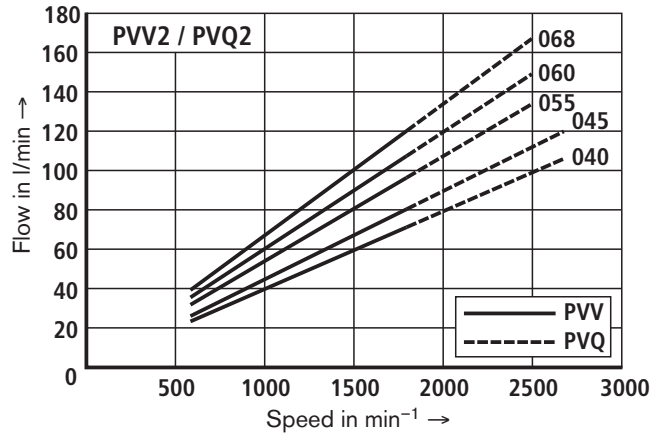
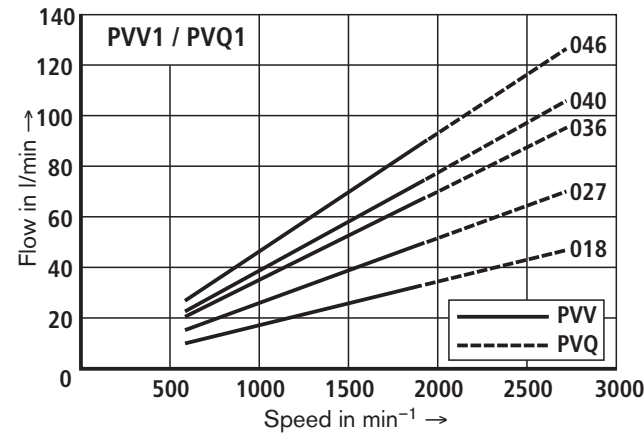

**Flow losses, pressure dependent** (measured at  $v = 41 \text{ mm}^2/\text{s}$ ;  $\vartheta = 50 \text{ }^\circ\text{C}$ )

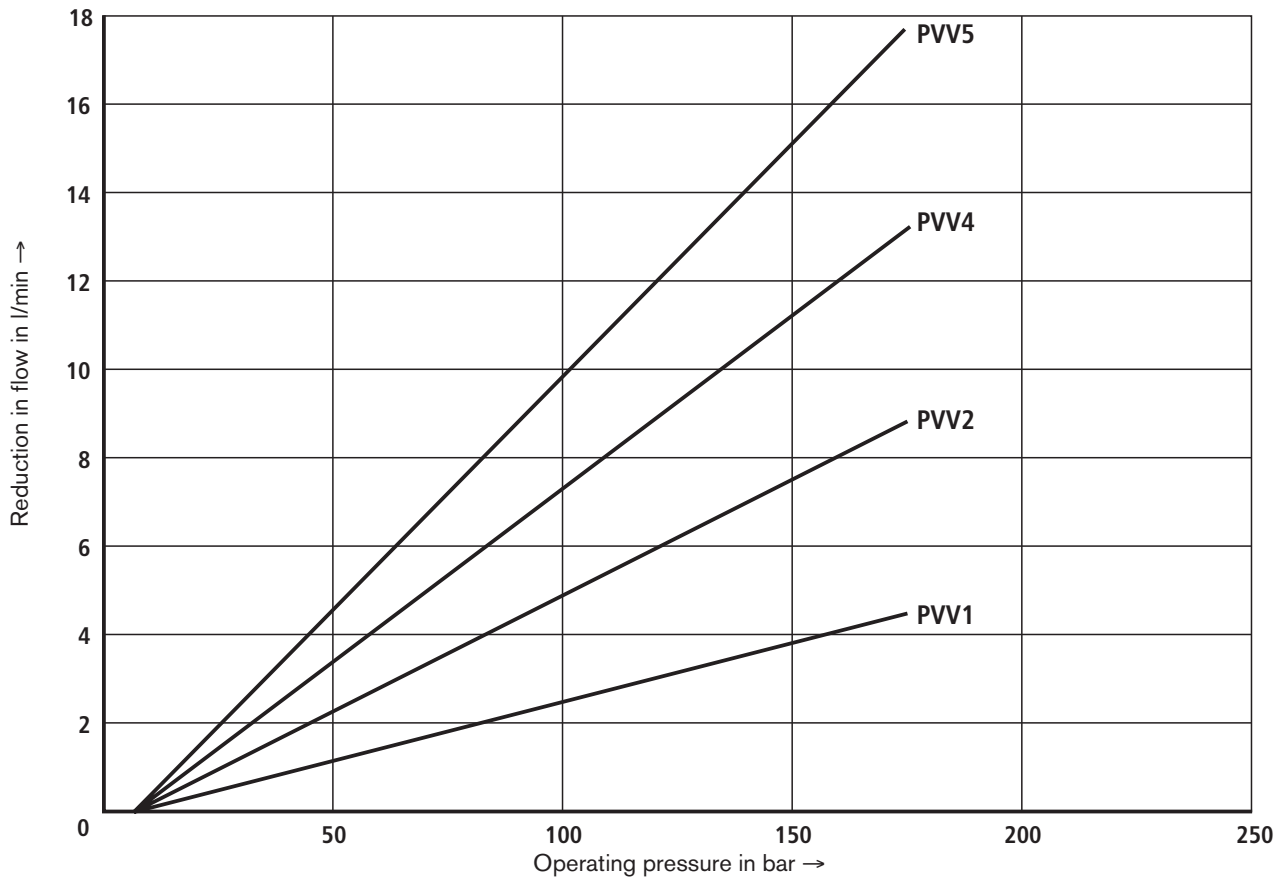

**Unit dimensions: single pumps PVV / PVO, BS1 (nominal dimensions in mm)**

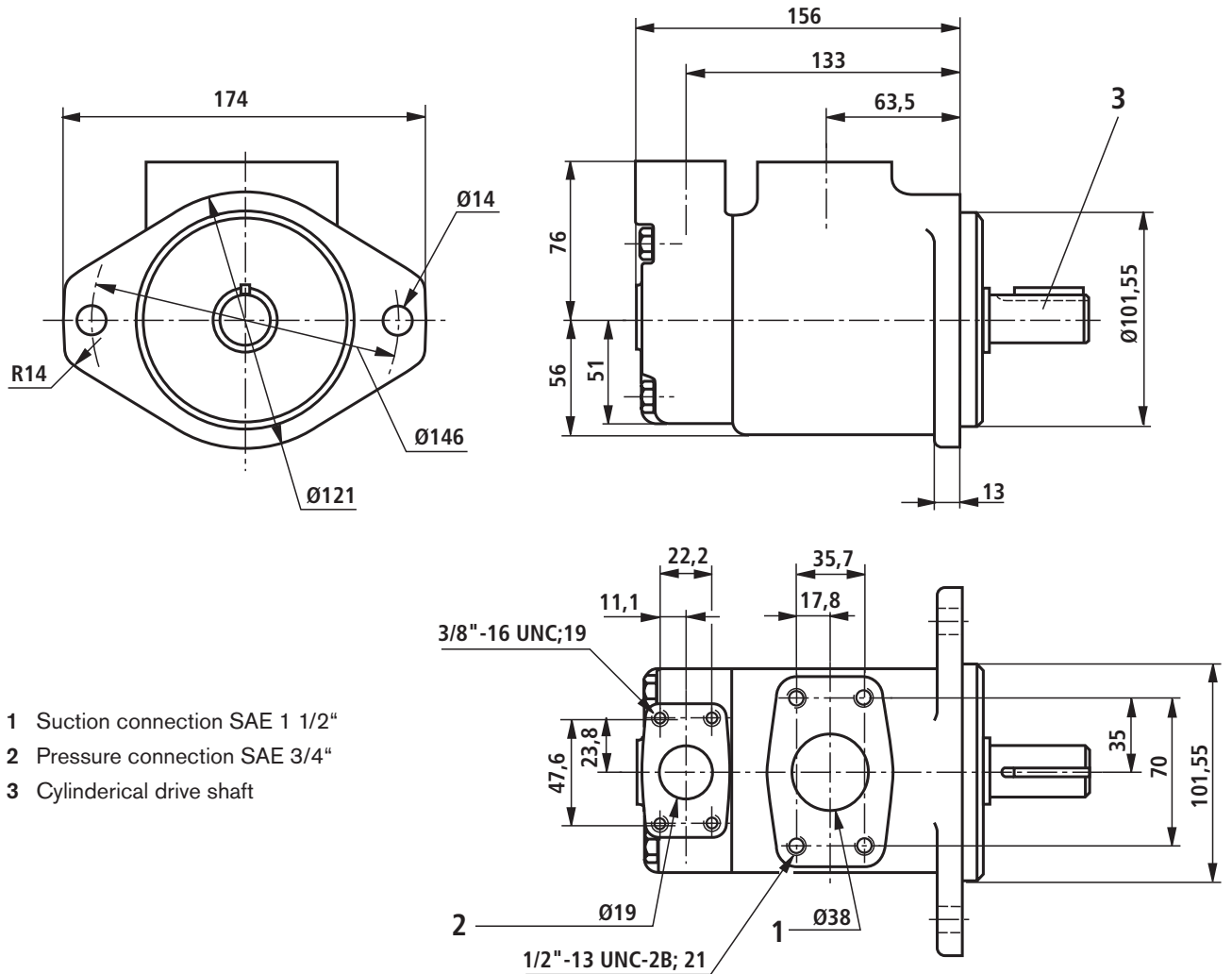

- 1 Suction connection SAE 1 1/2"
- 2 Pressure connection SAE 3/4"
- 3 Cylindrical drive shaft

**Shaft for BS1**

**Version A**

Cylindrical drive shaft (standard)

4 Key  $\square 4.76 \times 31.8$

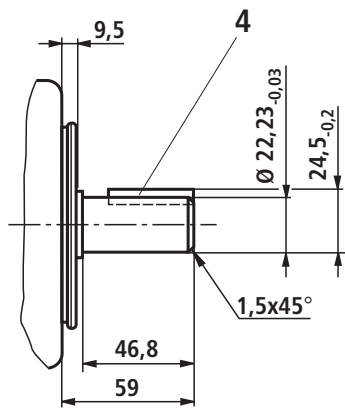

Permissible torque 250 Nm

**Version J**

Splined drive shaft SAE-B 7/8"

13 teeth 16/32DP

Tooth thickness  $t = 2.261$

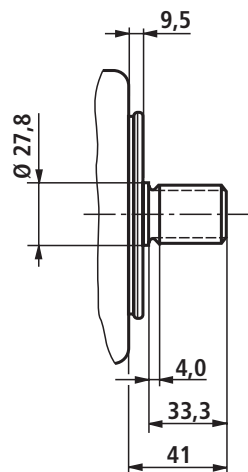

Permissible torque 316 Nm

**Unit dimensions: single pumps PVV / PVQ, BS2; 4; 5 (nominal dimensions in mm)**

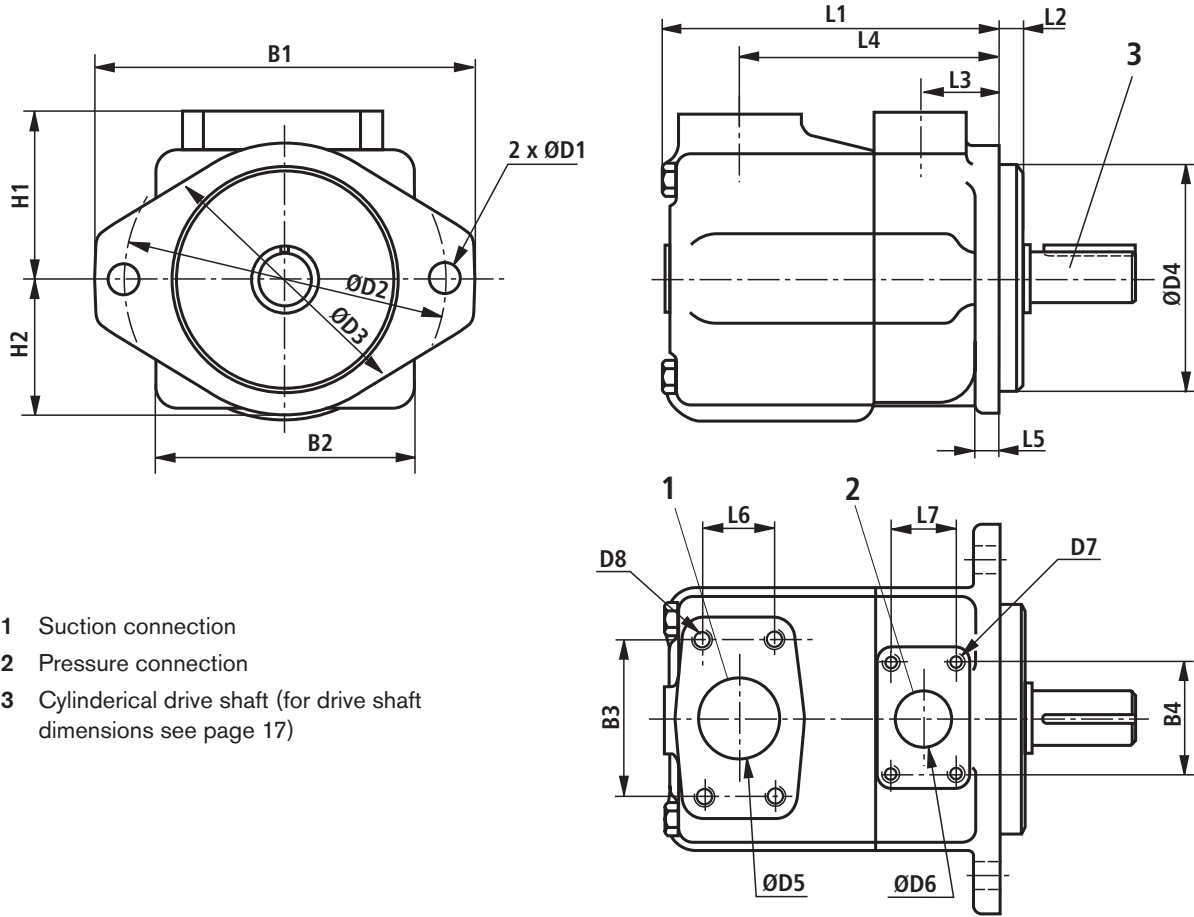

BS	Suction connection						
		ØD5	D8 <sub>-2B</sub>	B3	L6	L4	H1
2	SAE 1 1/2"	38	1/2"-13UNC; 22	69,9	35,7	120,6	76,2
4	SAE 2"	50,8	1/2"-13UNC; 23,8	77,7	42,8	125,5	82,6
5	SAE 3"	76,2	5/8"-11UNC; 28,6	106,3	61,9	153,2	93,6

BS	Pressure connection					
		ØD6	D7 <sub>-2B</sub>	B4	L7	L3
2	SAE 1"	25,4	3/8"-16UNC; 19	52,4	26,2	38,1
4	SAE 1 1/4"	31,8	7/16"-14UNC; 22	58,7	30,1	38,1
5	SAE 1 1/2"	38,1	1/2"-13UNC; 23,8	69,9	35,7	42,9

BS	Mounting flange										
		B1	ØD1	ØD2	ØD3	ØD4 <sub>0,05</sub>	L2	L5	B2	L1	H2
2	SAE-B	174	14	146	121	101,6	9,5	13	117	163	64
4	SAE-C	212	17,5	181	148	127	9,5	16	140	186	70
5	SAE-C	212	17,5	181	148	127	12,7	16	159	216	83

Unit dimensions: PVV / PVQ 2...K.. – with through drive (nominal dimensions in mm)

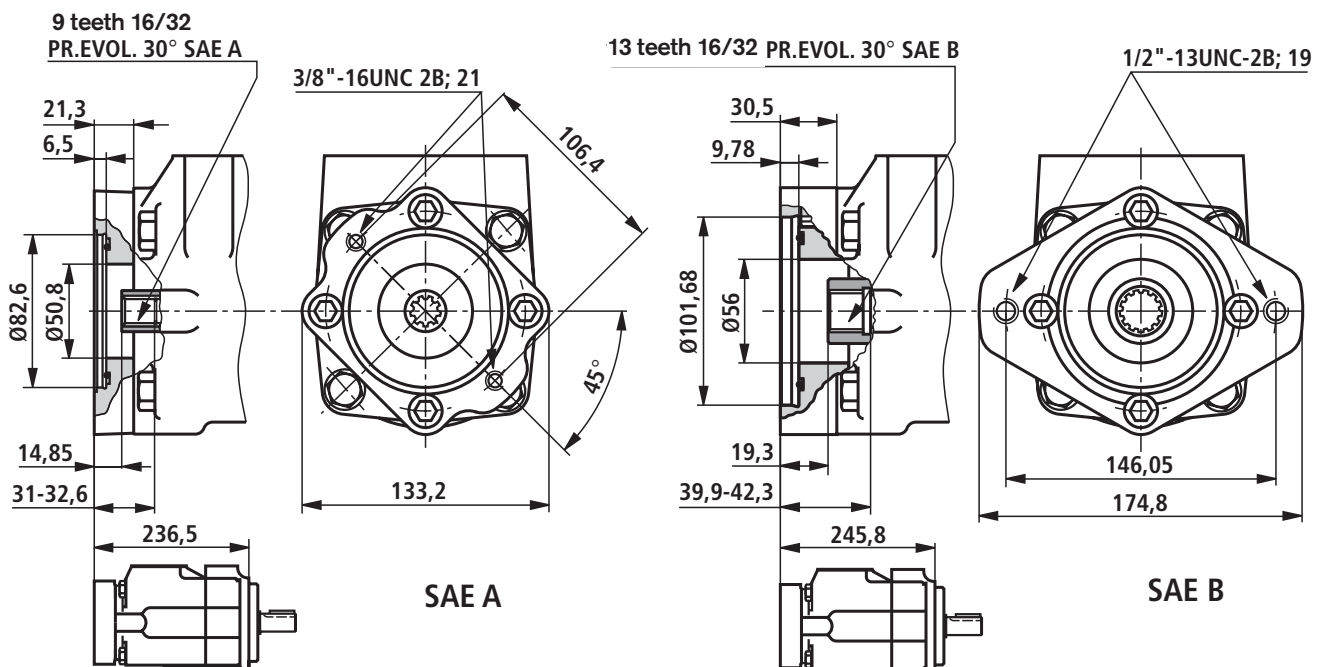
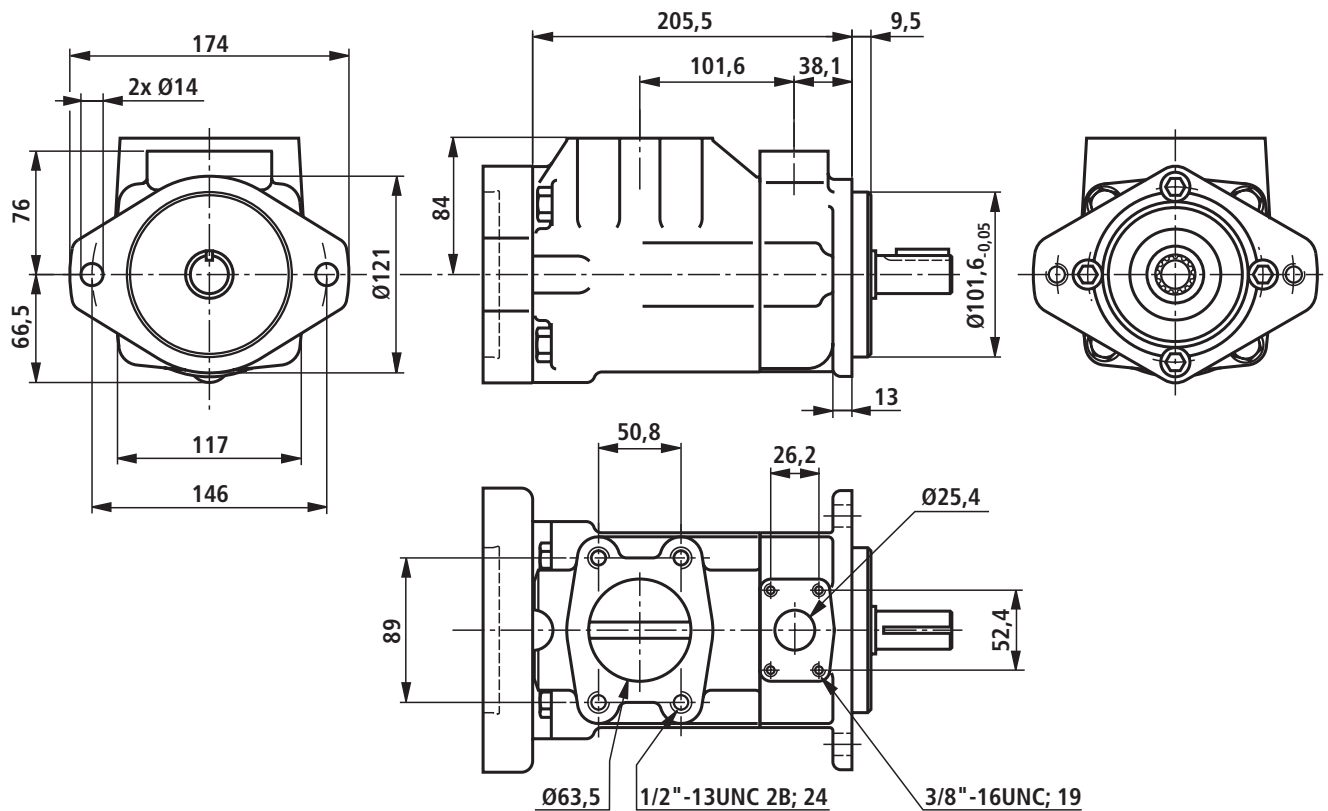

Unit dimensions: PVV / PVQ 4...K.. – with through drive (nominal dimensions in mm)

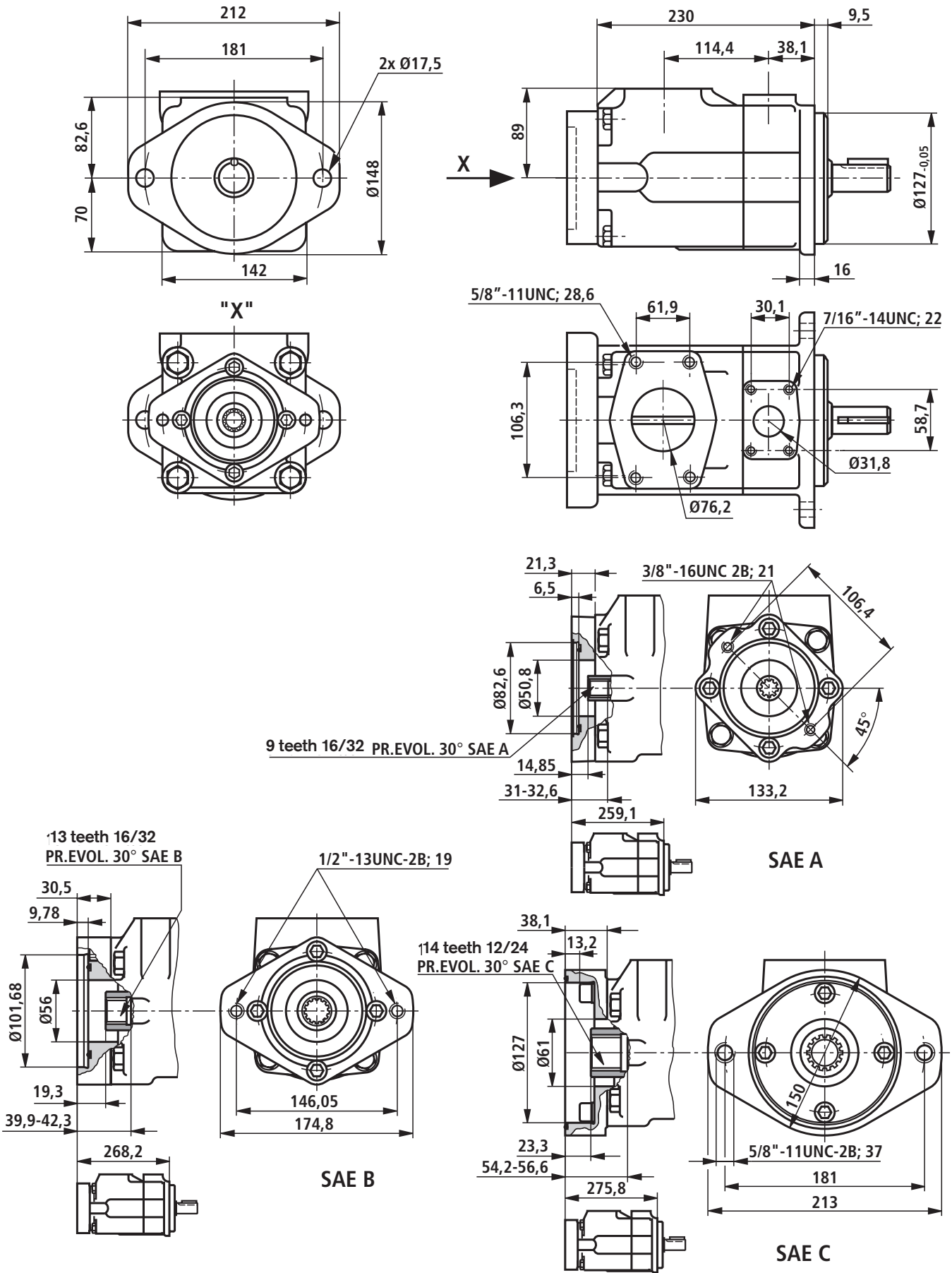

Unit dimensions: PVV / PVQ 5...K.. – with through drive (nominal dimensions in mm)

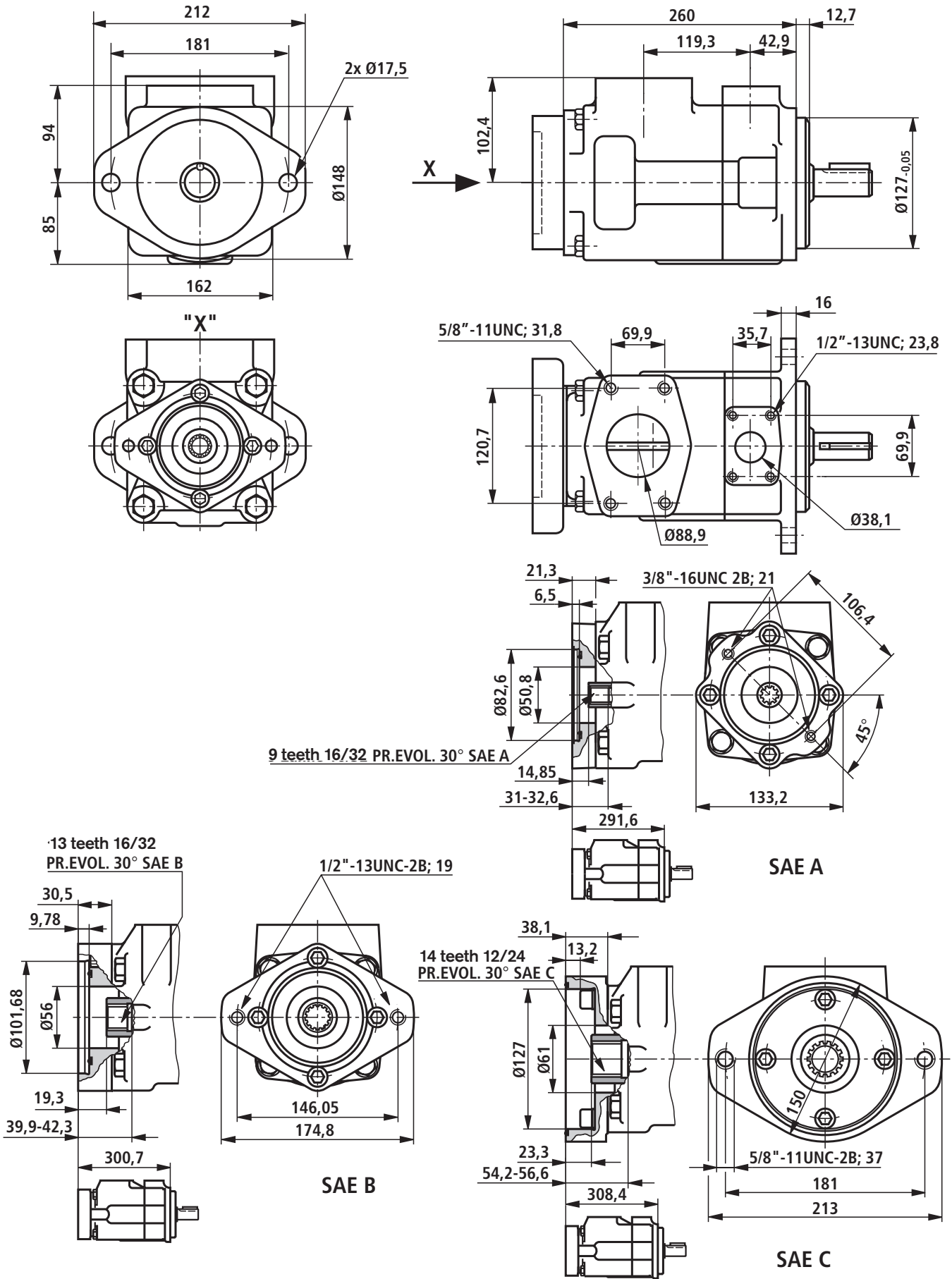

**Unit dimensions: double pumps PVV / PVQ, BS21; 41; 42; 51; 52 (nominal dimensions in mm)**

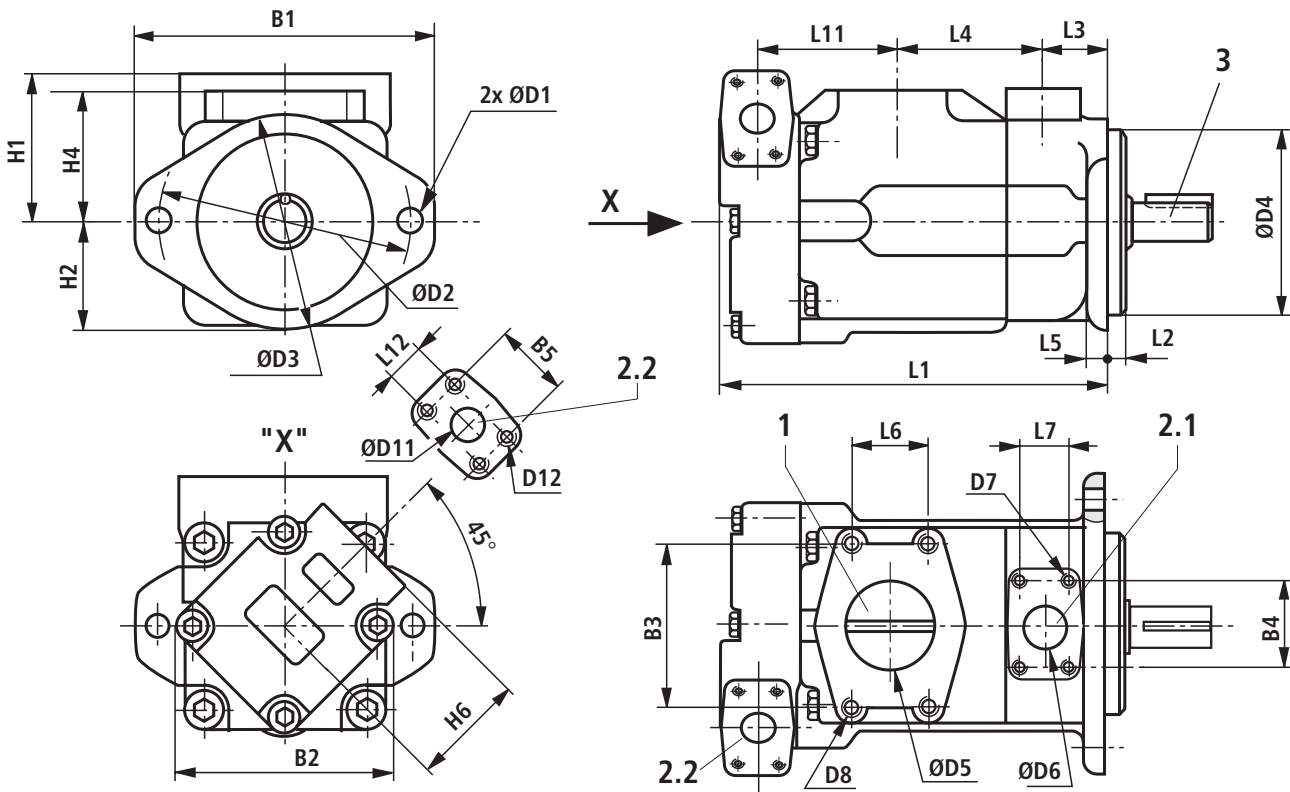

BS	Mounting flange							
	B1	ØD1	ØD2	ØD3	ØD4 <sub>-0,05</sub>	L2	L5	
21	SAE-B	174	14	146	121	101,6	9,5	13
41; 42	SAE-C	212	17,5	181	148	127	9,5	16
51; 52	SAE-C	212	17,5	181	148	127	12,7	16

BS	Suction connection						
	ØD5	D8 <sub>-2B</sub>	B3	L6	L4	H1	
21	SAE 2 1/2"	63,5	1/2"-13UNC; 23,8	88,5	50,8	101,6	84,1
41; 42	SAE 3"	76,2	5/8"-11UNC; 28,6	106,3	61,9	114,4	88,9
51; 52	SAE 3 1/2"	88,9	5/8"-11UNC; 31,8	120,7	69,9	119,3	102,4

BS	Pressure connection - flange side						
	ØD6	D7 <sub>-2B</sub>	B4	L7	L3	H4	
21	SAE 1"	25,4	3/8"-16UNC; 19,1	52,4	26,2	38,1	76,2
41; 42	SAE 1 1/4"	31,8	7/16"-14UNC; 21,6	58,7	30,1	38,1	82,6
51; 52	SAE 1 1/2"	38,1	1/2"-13UNC; 23,8	69,9	35,7	42,9	93,6

BS	Pressure connection - cover side									
	ØD11	D12 <sub>-2B</sub>	B5	L12	L11	H6	B2	L1	H2	
21	SAE 3/4"	19,1	3/8"-16UNC; 19,1	47,6	22,2	88	76,2	132	252	64
41	SAE 3/4"	19,1	3/8"-16UNC; 19,1	47,6	22,2	99,5	74,7	140	275	70
42	SAE 1"	25,4	3/8"-16UNC; 19,1	52,4	26,2	109,5	76,2	143	288	74
51	SAE 3/4"	19,1	3/8"-16UNC; 19,1	47,6	22,2	119,5	74,7	162	306	85
52	SAE 1"	25,4	3/8"-16UNC; 19,1	52,4	26,2	135,8	76,2	162	324	85

- 1 Suction connection
- 2.1 Pressure connection, flange side
- 2.2 Pressure connection, cover side
- 3 Cylindrical drive shaft (for drive shaft dimensions see page 18)

**Unit dimensions: double pumps PVV / PVO, BS54 (nominal dimensions in mm)**

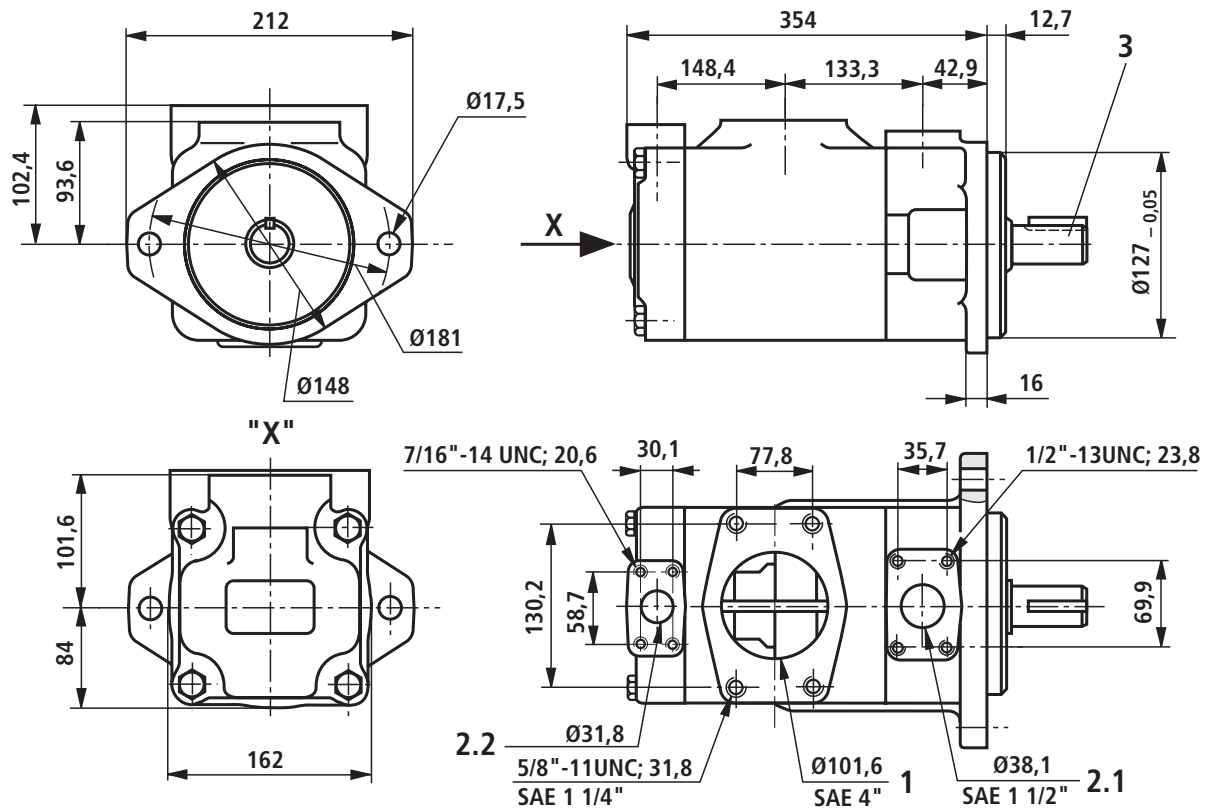

- 1 Suction connection
- 2.1 Pressure connection, flange side
- 2.2 Pressure connection, cover side
- 3 Cylindrical drive shaft  
(for drive shaft dimensions see table)
- 4 Key (for dimensions see table)

### Drive shaft for BS2 to 54

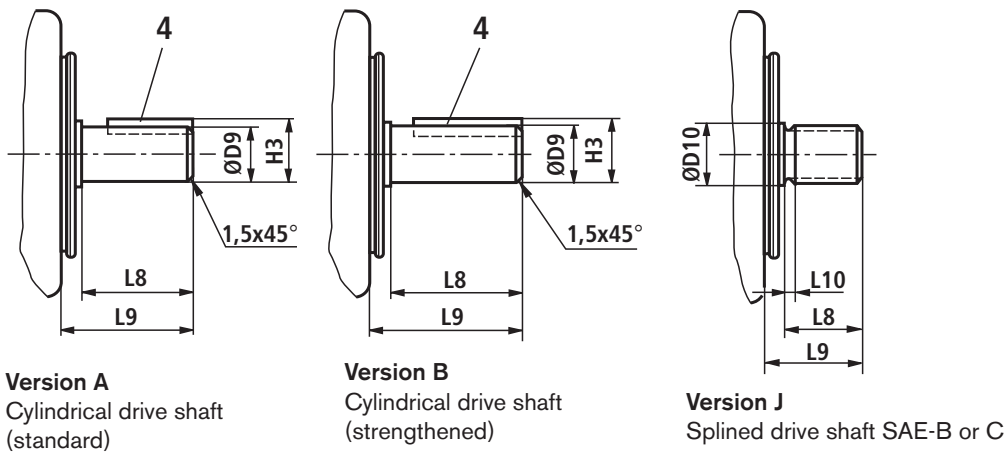

BS	Drive shaft version A						Drive shaft version B					
	L8	L9	H3	ØD9	Key	$T_{max}$ in Nm	L8	L9	H3	ØD9	Key	$T_{max}$ in Nm
2; 21	46,8	59	24,5 <sub>-0,2</sub>	22,23 <sub>-0,03</sub>	□ 4,76 x 31,8	250	64	78	28,3 <sub>-0,2</sub>	25,37 <sub>-0,02</sub>	□ 6,36 x 50,8	400
4; 41; 42	61,9	73,2	35,2 <sub>-0,3</sub>	31,75 <sub>-0,03</sub>	□ 7,9 x 38,1	407	74,6	86	38,6 <sub>-0,3</sub>	34,9 <sub>-0,03</sub>	□ 7,9 x 54,6	600
5; 51; 52; 54	47,8	62	35,2 <sub>-0,3</sub>	31,75 <sub>-0,03</sub>	□ 7,9 x 28,4	610	73	88	42,37 <sub>-0,23</sub>	38,07 <sub>-0,02</sub>	□ 9,5 x 54,6	810

BS	Drive shaft version J					$T_{max}$ in Nm	Teeth details
	L8	L9	L10	ØD10			
2; 21	33,3	41	4,0	27,8	316	SAE-B 7/8", 13 teeth, 16/32 DP	
4; 41; 42	42,1	56	3,04	35,05	580	SAE-C 1 1/4", 14 teeth, 12/24 DP	
5; 51; 52; 54	46,6	56	9,7	41,28	818	SAE-C 1 1/4", 14 teeth, 12/24 DP	

Maximum permissible through drive torques in Nm

BS	Through drive		
	K01 (SAE-A, 9T)	K02 (SAE-B, 13T)	K07 (SAE-C, 14T)
2	131	316	—
4	131	316	437
5	131	384	702

## Pump cartridges for PVV / PVQ

### Features

- Service friendly due to exchangeable pump cartridges
- Within a build size it is possible to change the flow by exchanging the pump cartridges
- The pump can be changed from type PVV to PVQ or PVQ to PVV by changing the cartridges.



H/A/D5768/97

Type: CARTRIDGE PVV1-1X/018R

### Ordering details

EINBAUSATZ	PV		-1X /		
------------	----	--	-------	--	--

#### Pump type

Industrial version	= V
Mobile version	= Q

Build size 1	= 1
Build size 2	= 2
Build size 4	= 4
Build size 5	= 5

#### Component series

Component series 10 to 19 (10 to 19: unchanged installation and connection dimensions)	= 1X
---	------

No code = Cartridge for single pumps or flange size for double pumps  
 D = Cartridge for cover side installation for double pumps

**Direction of rotation**  
 R = Clockwise  
 L = Anti-clockwise

#### Nominal size / displacement flow

018 =		18,0 cm <sup>3</sup>
027 =		27,4 cm <sup>3</sup>
036 =	Build size 1	45,4 cm <sup>3</sup>
040 =		39,5 cm <sup>3</sup>
046 =		45,9 cm <sup>3</sup>
040 =		40,1 cm <sup>3</sup>
045 =		45,4 cm <sup>3</sup>
055 =	Build size 2	55,2 cm <sup>3</sup>
060 =		60,0 cm <sup>3</sup>
068 =		67,5 cm <sup>3</sup>
069 =		69,0 cm <sup>3</sup>
082 =		81,6 cm <sup>3</sup>
098 =	Build size 4	97,7 cm <sup>3</sup>
113 =		112,7 cm <sup>3</sup>
122 =		121,6 cm <sup>3</sup>
139 =		138,6 cm <sup>3</sup>
154 =		153,5 cm <sup>3</sup>
162 =	Build size 5	162,2 cm <sup>3</sup>
183 =		183,4 cm <sup>3</sup>
193 =		193,4 cm <sup>3</sup>

### SAE connection flanges (nominal dimensions in mm)

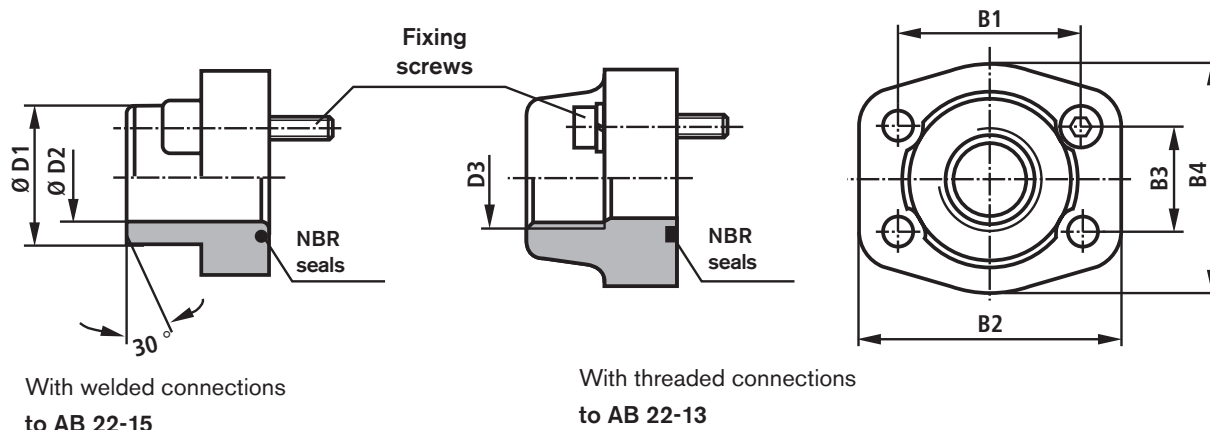

Suction connection	Pressure connection for PVV / PVQ *)	NS	Seal material	Material No. for flange with		B1	B2	B3	B4	ØD1	ØD2	D3	Fixing screws
				Welded connection	Threaded connection								
	<b>1; 21; 41; 51</b>	3/4"	NBR	R900211169	R900063050	47,6	65	22,2	52	25	19	G3/4	3/8"-16UNC
	<b>2; 21; 42; 52</b>	1"	NBR	R900211170	R900211175	52,4	70	26,2	59	30	22	G1	3/8"-16UNC
	<b>4; 41; 42; 54</b>	1 1/4"	NBR	R900211363	R900211172	58,7	79	30,2	68	38	28	G1 1/4	7/16"-14UNC
	<b>5; 51; 52; 54</b>	1 1/2"	NBR	R900211168	R900211171	69,9	95	35,7	76	38	30	G1 1/2	1/2"-13UNC
1; 2		1 1/2"	NBR	R900211165	R900211171	69,9	95	35,7	76	48	39	G1 1/2	1/2"-13UNC
4		2"	NBR	R900211434	R900211173	77,8	102	42,9	90	60	49	G2	1/2"-13UNC
21		2 1/2"	NBR	R900063063	R900211174	88,9	114	50,8	104	76	62	G2 1/2	1/2"-13UNC
5; 41; 42		3"	NBR	R900211362	-	106,3	135	61,9	131	76	70	-	5/8"-11UNC
51; 52		3 1/2"	NBR	R900211166	-	130,7	152	69,9	140	89	82	-	5/8"-11UNC
54		4"	NBR	R900211167	-	130,2	162	77,8	152	114	107	-	5/8"-11UNC

\*) The numbers in bold states the stage (for double pumps) for which the flange is intended.

The material numbers contain the flange, the O-ring and the fixing screws.

Pipe thread "G" to ISO 228/1

### Pump safety block

To limit the working pressure or (and) for solenoid operated unloading of the operating pressure we recommend the use of our pump safety blocks to RE 25880 and RE 25890.

## Engineering guidelines

---

Comprehensive guidelines and proposals can be found in the Hydraulic Trainer, Volume 3, RE 00281, "Planning and design of hydraulic power systems."

When using vane pumps we recommend that the following guidelines are partially taken into account.

### Technical data

All the technical data are dependent on manufacturing tolerances and are valid with certain operating conditions.

Please take into account that minor variations are possible and technical data can be affected by differing conditions (e.g. viscosity).

### Characteristic curves

Please take into account when dimensioning the drive motor, the maximum possible application data as shown by the characteristic curves on pages 8 to 10.

## Commissioning guidelines

---

### Commissioning

- Check to see if the system has been carefully, correctly and cleanly assembled.
- Only fill the pressure fluid via a filter which has the necessary retention rate.
- Take into account the direction of rotation arrow.
- Start the pump without load and let it displace oil without pressure for a few seconds, in order to provide sufficient lubrication.
- Never run the pump without oil.
- If the pump, after approx. 20, does not displace oil without any bubbles then the system has to be rechecked.  
After the operating values have been reached, check the pipe connections for leakage and check the operating temperature.

### Bleeding

- Before commissioning we recommend that the housing and suction line are filled with oil. This increases the operating safety and prevents wear in the case of unfavourable installation conditions.
- For the first commissioning the oil, which has foamed, can be released by carefully loosening the pressure flange (danger of oil spray) when the system is in a de-pressurised condition. Only when bubble-free oil is being released retighten the fittings to the required torque level.

### Noise

The sound pressure level values given on page 8 are measured according to DIN 45635, sheet 26. This means that only the noise emission of the pump is given. Ambient influences (such as place of installation, piping, etc.) are not taken into account.

### The values only refer to one pump.

Unfavourable influences can cause the noise pressure level at the units final place of installation to be 5 to 10 dB (A) higher than that of the pump values alone.

### General

- The pumps supplied by ourselves have been tested for function and performance. Changes in any form or manner to the pump are not permitted, as this would invalidate any guarantee claims!
- Repairs may only be carried out by the manufacturer of authorised agent or subsidiary. No guarantee will be accepted for commissioning carried.

### Note!

- Assembly, maintenance and servicing must only be carried out by authorised, trained and instructed personnel!
- The pumps must only be operated within the permitted limits (see pages 6 and 7)!
- The pump may only be operated in a sound condition!
- When carrying out any work on the pump, switch the system to zero pressure!
- Unauthorised conversions and modifications which affect the safety and function of the pump are not permitted!
- Provide protective measures (e.g. coupling guard) and do not remove any existing protective devices!
- Ensure that the fixing bolts are correctly fitted! (Take into account the prescribed tightening torques)
- The general valid safety and accident prevention regulations must be adhered to!

## Installation guidelines

### Drive

E-motor + pump mounting bracket + coupling + pump

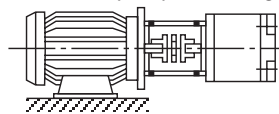

#### ⚠ Attention!

- Radial and axial forces on the pump drive shaft are not permitted!
- Motor and pump must be exactly aligned!
- Use flexible drive couplings

### Fluid tank

- Match the service capacity of the tank to the operating conditions.

#### ⚠ Attention!

The permissible fluid temperature must not be exceeded

- If required, provide a cooler!

### Lines and connections

- Cut at a 45° angle
- Remove protective plugs from the pump
- We recommend the use of seamless precision steel pipes to DIN 2391 and removable pipe connections.
- Select the inside diameter of the pipes according to the ports
- Thoroughly clean the pipes and fittings before assembly. – **min. distance to the tank bottom 120 mm**
  - Dirt deposits will not be sucked up or whirled up
- Maintain a minimum immersion depth of 50 mm, even at the lowest permissible fluid level
  - Foaming will be prevented
- Under no circumstances must leakage and return fluid be directly taken up by the pump!
  - Fluid temperature remain low
- For inlet pressure see page 6

### Piping recommendations

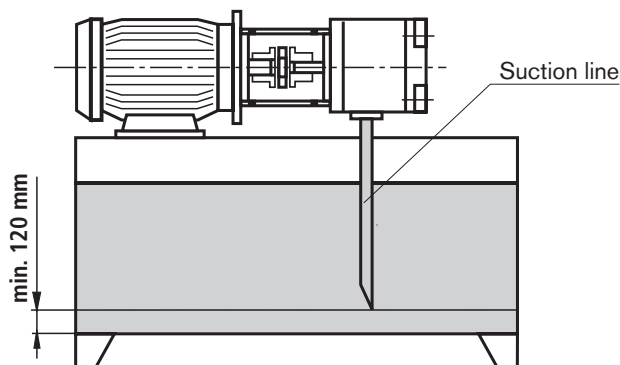

- **Under no circumstances** may return fluid be directly taken up, therefore select the greatest possible distance between the suction and return lines
- The exit of the return line must always lie under the oil level
- Ensure that the suction lines are assembled leak-proof

### Filter

- Whenever possible, use return line or pressure filters. (Suction filter only in connection with low pressure switch/clogging indicator)

### Pressure fluid

- Please take into account the specification stated in catalogue sheet RE 07075.
- We recommend the use of brand name fluids.
- Do not mix hydraulic fluid of different types since this can result in decomposition or deterioration of the lubricating quality.
- The fluid must be replaced at regular intervals according to the operating conditions. In connection with this, the tank must also be cleaned of residues.

### Permissible installation positions

- Horizontal position preferred

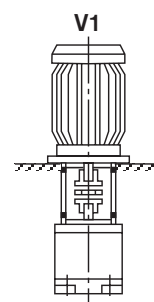
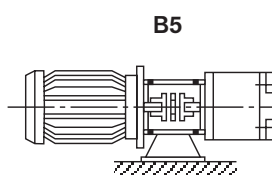
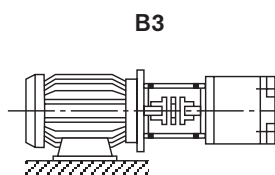

Bosch Rexroth AG  
Hydraulics  
Zum Eisengießer 1  
97816 Lohr am Main, Germany  
Telefon +49 (0) 93 52 / 18-0  
Telefax +49 (0) 93 52 / 18-23 58  
documentation@boschrexroth.de  
www.boschrexroth.de

© This document, as well as the data, specifications and other informations set forth in it, are the exclusive property of Bosch Rexroth AG. Without their consent it may not be reproduced or given to third parties. The data specified above only serves to describe the product. No statements concerning a certain condition or suitability for a certain application can be derived from our information. The details stated do not release you from the responsibility for carrying out your own assessment and verification. It must be remembered that our products are subject to a natural process of wear and ageing.