

Variable Plug-In Motor A6VE

RE 91 606/10.07 1/16
Replaces: 06.05

Technical data sheet

Series 6

Size	Nominal pressure / Peak pressure
28 to 160	400 / 450 bar
250	350 / 400 bar
Open and closed circuits	



Contents

Ordering Code / Standard Program	2
Technical Data	4
Unit Dimensions, Port Plate 02	6
Unit Dimensions, Port Plate 22 with Integral Counterbalance Valve	8
Circuit Diagram for Port Plate 22	9
Flush and Boost Pressure Valve	10
Speed Measurement	11
Connectors for Solenoids (only for EP, EZ, DA)	12
Installation Notes	13
Project Sheet	14
General Notes	16

Features

- Variable plug-in motor with axial tapered piston rotary group of bent axis design for hydrostatic drives in open and closed circuits
- Easy assembly, simply «plugs-in» into mechanical gearboxes (no installation tolerances to consider)
- The design of the motor with the mounting flange in the center of the housing allows it to be almost fully integrated into a mechanical gearbox to give an extremely compact unit
- For use in mobile applications
- Installation ready and tested unit
- The displacement is infinitely variable from $V_{g \max}$ to $V_{g \min} = 0$
- The output speed is dependent on the flow of the pump and the displacement of the motor
- The torque increases with the pressure differential between the high and low pressure side and with increasing displacement
- Further information:
Variable motor A6VM _____ RE 91604

Ordering Code / Standard Program

A6V	E					/	63	W		-	V								
01	02	03	04	05	06		07	08	09		10	11	12	13	14	15	16	17	18

Axial piston unit

01	Bent-axis design, variable	A6V
----	----------------------------	------------

Operation mode

02	Motor, plug-in version	E
----	------------------------	----------

Size

03	≈ Displacement $V_{g \max}$ in cm^3	28	55	80	107	160	250
----	--	----	----	----	-----	-----	-----

Control device

		28	55	80	107	160	250		
04	Hydraulic control, pilot-pressure related	$\Delta p = 10 \text{ bar}$	●	●	●	●	●	●	HD1
		$\Delta p = 25 \text{ bar}$	●	●	●	●	●	●	HD2
	Hydraulic two-point control		-	-	-	-	-	●	HZ
			●	-	-	-	●	-	HZ1
			-	●	●	●	● ¹⁾	-	HZ3
	Electric control, proportional	12 V	●	●	●	●	●	●	EP1
		24 V	●	●	●	●	●	●	EP2
	Electric two-point control, with switching solenoid	12 V	●	-	-	-	●	●	EZ1
		24 V	●	-	-	-	●	●	EZ2
		12 V	-	●	●	●	-	-	EZ3
		24 V	-	●	●	●	-	-	EZ4
	Automatic control, high-pressure related	Without pressure increase	●	●	●	●	●	●	HA1
With pressure increase $\Delta p=100\text{bar}$		●	●	●	●	●	●	HA2	
Without pressure increase		-	●	●	●	● ¹⁾	-	HA3 ¹⁾	
Hydraulic control, speed related	$p_{St}/p_{HD}=3/100$, hydraulic travel direction valve	-	-	-	-	-	●	DA	
	$p_{St}/p_{HD}=5/100$, el. travel direction valve + el. $V_{g \max}$ control	24V	●	●	●	●	●	-	DA3

Pressure control (only for HD, EP)

05	Without pressure control (without code)	
	Pressure control, direct	D

Overriding HA control

06	Without override (without code)	
	Hydraulic override	T

Series

07	Series 6, index 3	63
----	-------------------	-----------

Direction of rotation

08	Viewed from shaft end, alternating	W
----	------------------------------------	----------

Setting range for displacement ²⁾

		28	55	80	107	160	250	
09	$V_{g \min} = 0 \text{ to } 0.7 V_{g \max}$ (without code)	●	●	●	●	●	-	
	$V_{g \min} = 0 \text{ to } 0.4 V_{g \max}$ $V_{g \max} = V_{g \max} \text{ to } 0.8 V_{g \max}$	-	-	-	-	-	●	1
	$V_{g \min} > 0.4 V_{g \max} \text{ to } 0.8 V_{g \max}$ $V_{g \max} = V_{g \max} \text{ to } 0.8 V_{g \max}$	-	-	-	-	-	●	2

¹⁾ Only possible in connection with port plate 22 (integral counterbalance valve)

²⁾ Please specify exact setting for $V_{g \min}$ and $V_{g \max}$ in plain text when ordering: $V_{g \min} = \dots \text{ cm}^3$, $V_{g \max} = \dots \text{ cm}^3$

Ordering Code / Standard Program

A6V	E					/	63	W		-	V								
01	02	03	04	05	06		07	08	09		10	11	12	13	14	15	16	17	18

		Seals						28	55	80	107	160	250	
10	FKM (fluor-caoutchouc)						●	●	●	●	●	●	V	

		Shaft end												
11	Splined shaft DIN 5480						●	-	●	-	●	-	A	
							-	●	-	●	-	●	Z	

		Mounting flange						28	55	80	107	160	250	
12	2-hole, similar to ISO 3019-2						●	●	●	●	●	-	L	
	4-hole, similar to ISO 3019-2						-	-	-	-	-	●	M	
	2-hole (modified adaption flange)						-	-	-	●	-	-	U	

		Service line ports ³⁾												
13	SAE flange ports A/B side, opposite	02	0	●	●	●	●	●	●	●	●	●	020	
			7	●	●	●	●	●	●	●	●	●	027	
	Port plate with integral counterbalance valve (with brake release valve) and secondary valve; SAE flange ports A/B bottom ⁶⁾	22	1	-	●	●	●	●	●	●	-	-	221 ⁴⁾	
			2	-	●	●	●	●	●	●	-	-	222 ⁴⁾	

		Valves		
14	Without valve			0
	Brake release valve (pilot pressure for brake release)	Internal boring		1
		External piping		2
	With flush and boost pressure valve			7

		Speed measurement						28	55	80	107	160	250	
15	Without speed measurement (without code)						●	●	●	●	●	●		
	Prepared for speed measurement (HDD) ⁵⁾						-	●	●	●	●	-	F	

		Connector for solenoids (only sizes 28 to 160)				
		EP1/2	EZ1/2	EZ3/4	DA	
16	DEUTSCH - molded connector, 2-pin – without suppressor diode	●	●	○	●	P

		Start of control							
17	Port plate 02	At $V_{g \min}$ (standard for HA)	●	●	●	●	●	●	A
		At $V_{g \max}$ (standard for HD, HZ, EP, EZ, DA)	●	●	●	●	●	●	B
	Port plate 22	At $V_{g \min}$ (standard for HA3)	-	●	●	●	●	-	B
		At $V_{g \max}$ (standard for HZ3)	-	●	●	●	●	-	B

		Standard / special version		
18	Standard version	(without code)		
		With attachment part		-K
	Special version		-S	
		With attachment part		-SK

³⁾ Metric fixing threads

⁴⁾ Only possible in combination with HZ3, HA3 control

⁵⁾ Complete order recommended, speed sensor page 11

⁶⁾ Use project sheet for project planning of the integral counterbalance valve

● = available ○ = on request - = not available

 = preferred program

Technical Data

Hydraulic fluid

Before starting project planning, please refer to our data sheets RE 90220 (mineral oil), RE 90221 (environmentally acceptable hydraulic fluids) and RE 90223 (HF hydraulic fluids) for detailed information regarding the choice of hydraulic fluid and application conditions.

The A6VE variable plug-in motor is unsuitable for operation with HFA. If HFB, HFC and HFD or environmentally acceptable hydraulic fluids are being used, the limitations regarding technical data and seals mentioned in RE 90221 and RE 90223 must be observed.

When ordering, please indicate the used hydraulic fluid.

Operating viscosity range

For optimum efficiency and service life, select an operating viscosity (at operating temperature) within the optimum range of

$$v_{\text{opt}} = \text{optimum operating viscosity } 16 \text{ to } 36 \text{ mm}^2/\text{s}$$

depending on the circuit temperature (closed circuit) and tank temperature (open circuit).

Limits of viscosity range

The limiting values for viscosity are as follows:

Sizes 28 to 160:

$$v_{\text{min}} = 5 \text{ mm}^2/\text{s}$$

short-term ($t < 3 \text{ min}$)

at max. perm. temperature of $t_{\text{max}} = +115^\circ\text{C}$.

$$v_{\text{max}} = 1600 \text{ mm}^2/\text{s},$$

short-term ($t < 3 \text{ min}$)

at cold start ($p \leq 30 \text{ bar}$, $n \leq 1000 \text{ rpm}$, $t_{\text{min}} = -40^\circ\text{C}$).

Only for starting up without load. Optimum operating viscosity must be reached within approx. 15 minutes.

Size 250:

$$v_{\text{min}} = 10 \text{ mm}^2/\text{s},$$

short-term ($t < 3 \text{ min}$)

at max. perm. temperature of $t_{\text{max}} = +90^\circ\text{C}$.

$$v_{\mu\alpha\xi} = 1000 \text{ mm}^2/\text{s},$$

short-term ($t < 3 \text{ min}$)

at cold start ($p \leq 30 \text{ bar}$, $n \leq 1000 \text{ rpm}$, $t_{\text{min}} = -25^\circ\text{C}$).

Only for starting up without load. Optimum operating viscosity must be reached within approx. 15 minutes.

Note that the maximum hydraulic fluid temperature of 115°C (90°C at size 250) must not be exceeded locally either (e.g. in the bearing area). The temperature in the bearing area is - depending on pressure and speed - up to 12 K higher than the average case drain temperature.

Special measures are necessary in the temperature range from -40°C to -25°C (cold start phase); please contact us.

For detailed information about use at low temperatures, see RE 90300-03-B.

Filtration

The finer the filtration, the higher the cleanliness level of the hydraulic fluid and the longer the service life of the axial piston unit.

To ensure functional reliability of the axial piston unit, the hydraulic fluid must have a cleanliness level of at least 20/18/15 according to ISO 4406.

At very high hydraulic fluid temperatures (90°C to max. 115°C), at least cleanliness level of 19/17/14 according to ISO 4406 is required.

If the above classes cannot be observed, please contact us.

Operating pressure range

Maximum pressure on port A or B
(pressure data in accordance with to DIN 24312)

for sizes 28 to 160

Nominal pressure p_N _____ 400 bar

Peak pressure p_{max} _____ 450 bar

Total pressure (pressure A + pressure B) p_{max} _____ 700 bar

for size 250

Nominal pressure p_N _____ 350 bar

Peak pressure p_{max} _____ 400 bar

Total pressure (pressure A + pressure B) p_{max} _____ 700 bar

Please note:

These values are valid for loading which is free of radial forces. With additional radial loading, see RE 91604.

Direction of flow

Direction of rotation, viewed on shaft end

clockwise

counter-clockwise

A to B

B to A

Speed range

No limit to minimum speed n_{min} . If uniformity of motion is required, speed n_{min} must not be less than 50 rpm. See table of values on page 5 for maximum speed.

Technical Data

Shaft seal ring

Permissible pressure load

The service life of the shaft seal ring is affected by the speed of the motor and the case drain pressure. It is recommended that the average, continuous case drain pressure at operating temperature 3 bar absolute not be exceeded (max. permissible case drain pressure 6 bar absolute at reduced speed, see diagram). Short-term ($t < 0.1$ s) pressures spikes of up to 10 bar absolute are permitted. The service life of the shaft seal ring decreases with an increase in the frequency of pressures spikes.

The case pressure must be equal to or greater than the external pressure on the shaft seal ring.

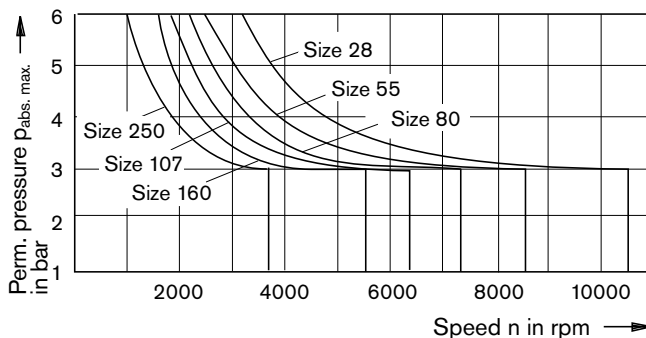

Temperature range

The FKM shaft seal ring is permissible for case temperatures of -25°C to $+115^{\circ}\text{C}$.

Note:

For application cases below -25°C , an NBR shaft seal ring is necessary (permissible temperature range: -40°C to $+90^{\circ}\text{C}$). Please state NBR shaft seal ring in plain text when ordering. Please contact us.

Effect of case pressure on start of control

An increase in the case pressure has an effect on the following controls when control of the variable motor begins:

HA1T (sizes 28 to 160) _____ increase
 HD, EP, HA, HA.T (size 250) _____ increase
 DA _____ decrease

The start of control is set in the factory at a case pressure of $p_{\text{abs}} = 2$ bar (sizes 28 to 160) and $p_{\text{abs}} = 1$ bar (size 250).

Table of values (theoretical values, without efficiency and tolerances; values rounded)

Size	Size	28	55	80	107	160	250
Displacement ¹⁾	$V_{g \text{ max}}$	28.1	54.8	80	107	160	250
	$V_{g \text{ 0}}$	0	0	0	0	0	0
Speed max. (while adhering to max. permissible flow)	n_{max} at $V_{g \text{ max}}$	5550	4450	3900	3550	3100	2700
	$n_{\text{max}1}$ at $V_g < V_{g1}$	8750	7000	6150	5600	4900	3600
	$V_{g1} = 0.63 \times V_{g \text{ max}}$	18	35	51	68	101	188 ²⁾
	$n_{\text{max}0}$ at $V_{g \text{ 0}}$	10450	8350	7350	6300	5500	3600
Max flow	qV_{max}	156	244	312	380	496	675
Max torque	T_{max} at $V_{g \text{ max}}$ ³⁾	179	349	509	681	1019	1391
Rotary stiffness	$V_{g \text{ max}}$ to $V_{g/2}$	5670	10400	15500	21000	35300	59500
	$V_{g/2}$ to 0 (interpolated)	18100	32000	47900	65200	105000	181000
Moment of inertia for rotary group	J_{TW}	0.0014	0.0042	0.008	0.0127	0.0253	0.061
Angular acceleration maximum	α	47000	31500	24000	19000	11000	10000
Filling capacity	V	0.5	0.75	1.2	1.5	2.4	3.0
Mass (approx.)	Port plate 02	16	26	34	47	64	90
	Port plate 22	–	35	43	53	72	–

¹⁾ The minimum and maximum displacements are infinitely variable, see ordering codes on page 2.
 (default settings for sizes 250 unless specified in order: $V_{g \text{ min}} = 0.2 \cdot V_{g \text{ max}}$, $V_{g \text{ max}} = V_{g \text{ max}}$).

²⁾ $V_{g1} = 0.75 \times V_{g \text{ max}}$ (approx.)

³⁾ Sizes 28 to 160: $\Delta p = 400$ bar; size 250: $\Delta p = 350$ bar

Caution: Exceeding the permissible limit values may result in a loss of function, a reduction in service life or in the destruction of the axial piston unit.
 Other permissible limit values with respect to speed variation, reduced angular acceleration as a function of the frequency and the permissible startup angular acceleration (lower than the maximum angular acceleration) can be found in data sheet RE 90261.

For further information see technical data sheet RE 91604 (variable motor A6VM):

- Selection diagram and details regarding the choice of hydraulic fluid
- Permissible displacement and inlet pressure in relation to speed
- Permissible radial and axial loading on drive shaft
- Description and dimensions of the control units

Unit Dimensions

Before finalizing your design, please request a binding installation drawing. Dimensions in mm

HD1, HD2 Hydraulic control, pilot-pressure related

SAE flange ports A/B side, opposite (02)

For unit dimensions of control units, see technical data sheet of variable motor A6VM (RE 91604)

Sizes 28 to 160

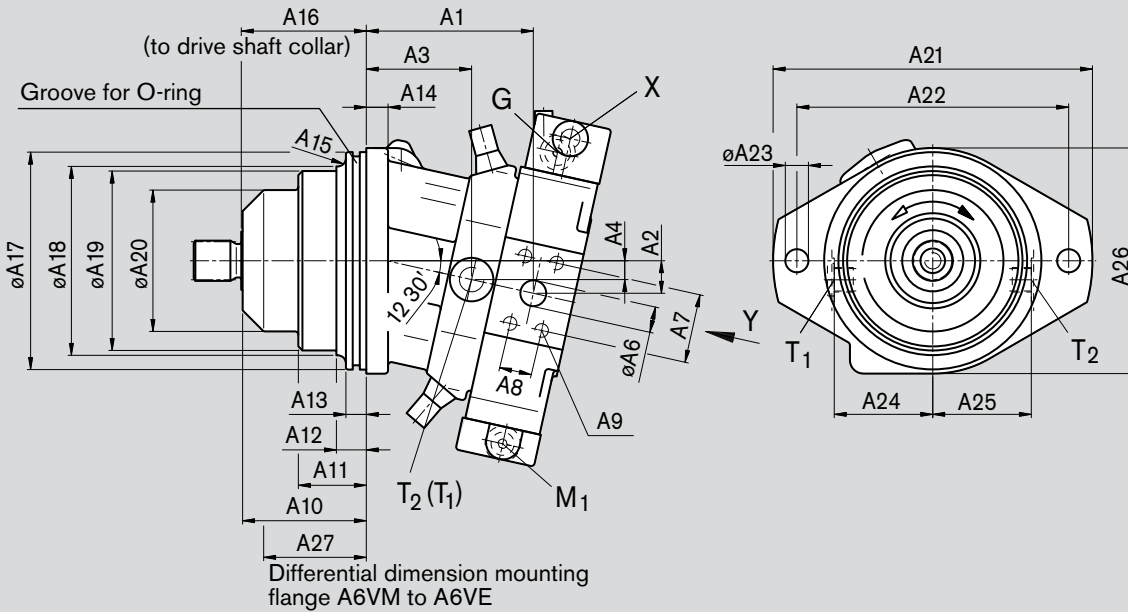

Detail Y

Size 250

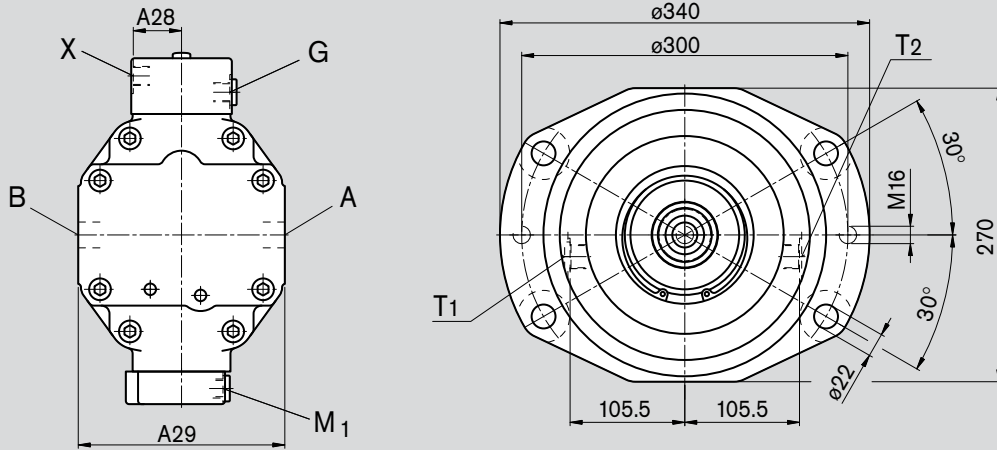

Ports

Size	Service line port A, B SAE J518	Case drain port T ₁ ; T ₂ ¹⁾ DIN 3852
28	3/4 in	M18x1.5; 12 deep 140 Nm ²⁾
55	3/4 in	M18x1.5; 12 deep 140 Nm ²⁾
80	1 in	M18x1.5; 12 deep 140 Nm ²⁾
107	1 in	M18x1.5; 12 deep 140 Nm ²⁾
160	1 1/4 in	M26x1.5; 16 deep 230 Nm ²⁾
250	1 1/4 in	M22x1.5; 14 deep 210 Nm ²⁾

¹⁾ 1x plugged ²⁾ Please observe the general notes for the max. tightening torques on page 16

For other ports, see variable motor A6VM (RE 91604)!

Unit Dimensions

Before finalizing your design, please request a binding installation drawing. Dimensions in mm

Standard flange L (sizes 28 to 160), M (size 250)

Size	A1	A2	A3	A4	øA6	A7	A8	A9 (DIN 13) ¹⁾	A10	A11	A12	A13	A14	A15
28	91	20	47	10	ø19	50.8	23.8	M10x1.5; 17 deep	88	54	–	15	14	R10
55	123	24	77	14	ø19	50.8	23.8	M10x1.5; 17 deep	91	50	22	15	16	R6
80	130	28	78	16	ø25	57.2	27.8	M12x1.75; 17 deep	109.5	65	30	15	18	R10
107	137	30	84	18	ø25	57.2	27.8	M12x1.75; 17 deep	121.8	72	35	15	18	R12
160	171	34	109	20	ø32	66.7	31.8	M14x2; 19 deep	122	67	29	15	20	R5
250	204	44	103	20	ø32	66.7	31.8	M14x2; 19 deep	131.5	–	–	14	25	–

Size	A16	A17	A18	A19	A20	A21	A22	øA23	A24	A25	A26	A27	A28	A29	O-ring ²⁾
28	89	135 _{0.025}	110	–	86	188	160	ø13.5	62.5	62.5	142	64	35.5	132	126x4
55	92	160 _{0.025}	139	132	104	235	200	ø17	72.5	72.5	166	59	35.5	152	150x4
80	110.5	190 _{0.029}	151	143	116	260	224	ø21	78.5	78.5	198	79	35.5	164	182x4
107	122.8	200 _{0.029}	168	160	132	286	250	ø21	86.5	86.5	210	82	40.5	180	192x4
160	123	200 _{0.029}	188	180	146	286	250	ø21	98.5	98.5	210	83	40.5	204	192x4
250	133.5	260 _{0.081}	–	230	–	–	–	–	–	–	–	83.5	48.5	224	250x5

Adaption flange U (size 107)

Size	A1	A2	A3	A4	A5	A6	A7	A8	A9 (DIN 13) ¹⁾	A10	A11	A12	A13	A14
107	150	30	96	18	15.5	25	57.2	27.8	M12x1.75; 17 deep	109.5	59.7	22.7	18	15

Size	A15	A16	A17	A18	A19	A20	A21	A22	A23	A24	A25	A26	A27	A28	A29	O-ring ²⁾
107	R8	110.5	190 _{0.025}	168	160	132	260	224	22	86.5	86.5	198	91.5	13.8	70	182x4

¹⁾ Please observe the general notes for the max. tightening torques on page 16

²⁾ The O-ring is not included in supply

Shaft ends

Splined shaft DIN 5480

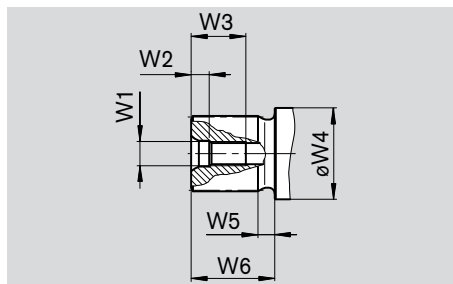

Size	Shaft end	W1	W2	W3	øW4	W5	W6
28	A (W30x2x30x14x9g)	M10	7.5	22	ø35	8	35
55	Z (W30x2x30x14x9g)	M12	9.5	28	ø45	8	35
80	A (W40x2x30x18x9g)	M16	12	36	ø50	8	45
107	Z (W40x2x30x18x9g)	M12	9.5	28	ø60	8	45
160	A (W50x2x30x24x9g)	M16	12	36	ø70	11	55
250	Z (W50x2x30x24x9g)	M16	12	36	ø60	9	58

Unit Dimensions

Before finalizing your design, please request a binding installation drawing. Dimensions in mm

HA3 Automatic control, high-pressure related without pressure increase

Port plate 22 with integral counterbalance valve

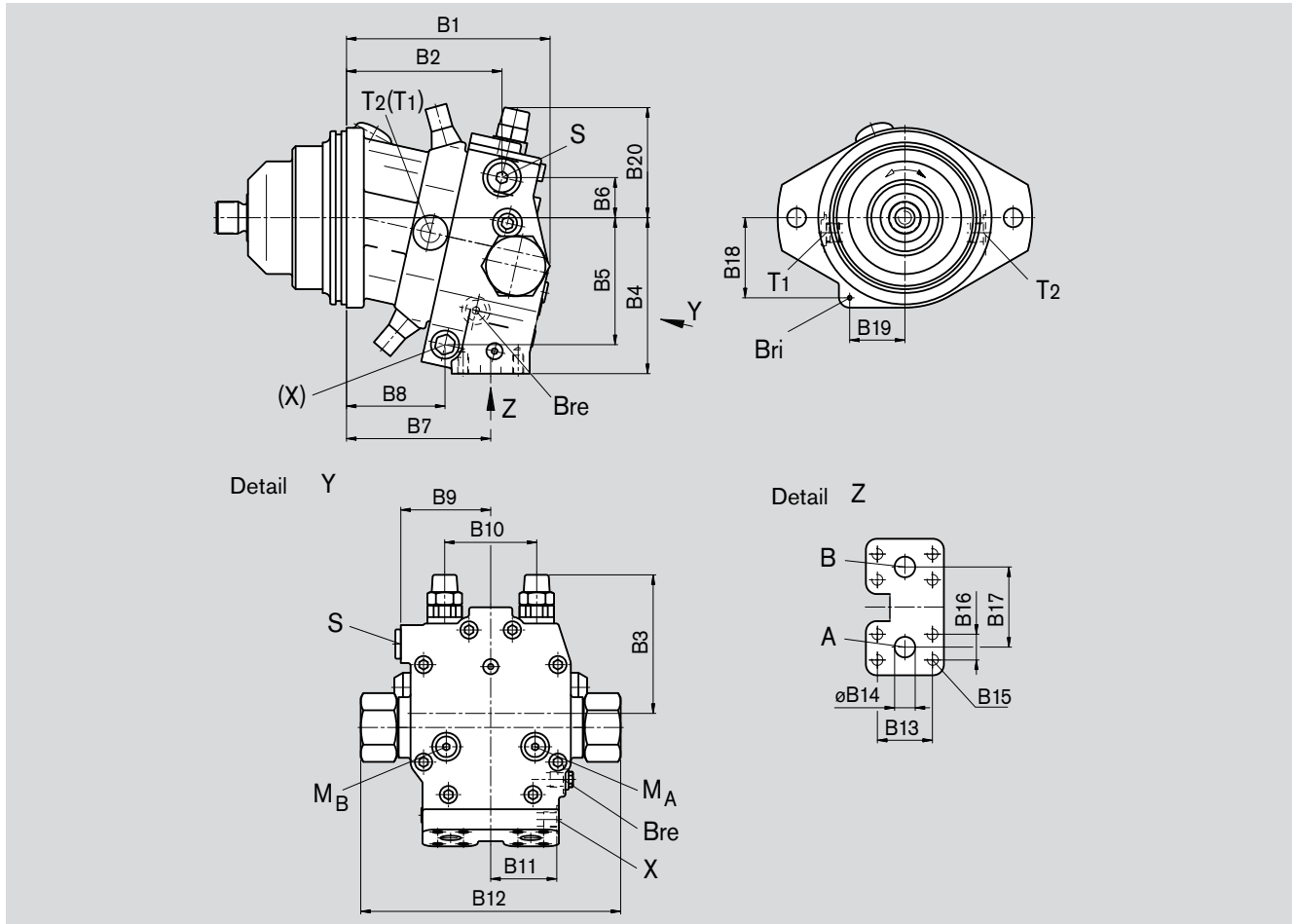

Ports

Size	B1	B2	B3	B4	B5	B6	B7	B8	B9	B10	B11	B12	B13	B14	B15 (DIN 13) ²⁾	B16	B17
55	192	144	127	144	117	37	133	91	83	85	64	259	50.8	19	M10x1.5; 17 deep	23.8	80
80	198	150	136	162	132	40	138	93	83	90	69	259	57.2	25	M12x1.75; 17 deep	27.8	86
107	202	161	139	171.5	143	40	144	99	85	96	72	259	57.2	25	M12x1.75; 17 deep	27.8	86
160	240	195	152	197	162	47	177	128	102	108	78	259	66.7	32	M14x2; 19 deep	31.8	94

Size	B18	B19	B20	Service line port A, B SAE J518	Case drain port T ₁ ; T ₂ ¹⁾ DIN 3852	Boosting S DIN 3852
55	74	51	102	3/4in	M18x1.5; 12 deep 140 Nm ²⁾	M22x1.5; 14 deep 210 Nm ²⁾
80	90	53	114	1in	M18x1.5; 12 deep 140 Nm ²⁾	M22x1.5; 14 deep 210 Nm ²⁾
107	96	58	122	1in	M18x1.5; 12 deep 140 Nm ²⁾	M22x1.5; 14 deep 210 Nm ²⁾
160	94	65	136	1 1/4in	M26x1.5; 16 deep 230 Nm ²⁾	M27x2; 16 deep 330 Nm ²⁾

¹⁾ 1x plugged

²⁾ Please observe the general notes for the max. tightening torques on page 16

X	Pilot pressure port (open for HZ3 and HA3T, closed for HA3)	DIN 3852	M14x1.5; 12 deep
M _A , M _B	Gauge port	DIN 3852	M14x1.5; 12 deep
Bre	External brake release port (open for design 222)	DIN 3852	M14x1.5; 12 deep
Bri	Internal brake release port (not present on design with flange U)		ø4

Note: Port plates HZ3 and HA3 are not identical!

Circuit Diagram

Before finalizing your design, please request a binding installation drawing. Dimensions in mm

For port plate 22 with integral counterbalance valve

A6VE...HA3...221 (Brake release via internal boring)
 (Port X open for HA3T)

A6VE...HZ3...222 (Brake release via external piping)

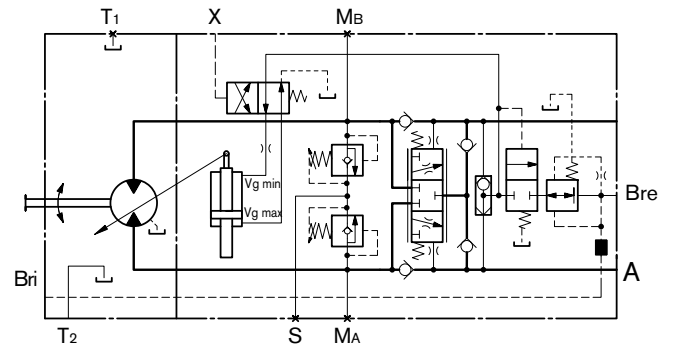
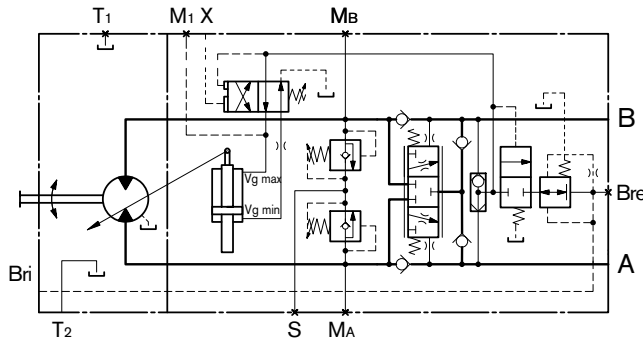

Flush and Boost Pressure Valve

The flush and boost pressure valve is used to remove heat from the closed circuit and to ensure that a minimum boost pressure is present (opening pressure 16 bar, fixed; note when setting primary valve). A side effect is the flushing of the case.

Warm hydraulic fluid is directed from the respective low pressure side into the motor case. This is then fed into the tank, together with the case drain fluid. The hydraulic fluid drawn out of the closed circuit in this way must be replaced by cooled hydraulic fluid that is supplied by the boost pump.

In an open circuit, the flush and boost pressure valve is used solely to flush the case from the return line.

The valve is fitted on the variable motor or integrated into the control unit (depending on the type of control and the size).

Orifices can be used to adjust the flushing volumes as required.

Standard flushing volume at low pressure $\Delta p_{LP} = 25$ bar

Size	Flushing volume	Mat. no. of orifice
28, 55	3.5 L/min	R909651766
80	5 L/min	R909419695
107	8 L/min	R909419696
160	10 L/min	R909419697
250	10 L/min	R909419697

For sizes 28 to 160, orifices for flushing volumes of 3.5 to 10 L/min can be supplied. In the case of non-standard flushing volumes, please specify the desired flushing volume when ordering. The flushing volumes without orifice is approx. 12 to 14 L at low pressure $\Delta p_{LP} = 25$ bar.

Sizes 28 to 160

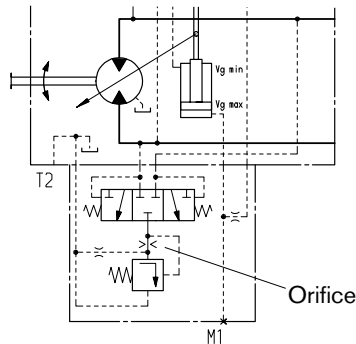

Size 250

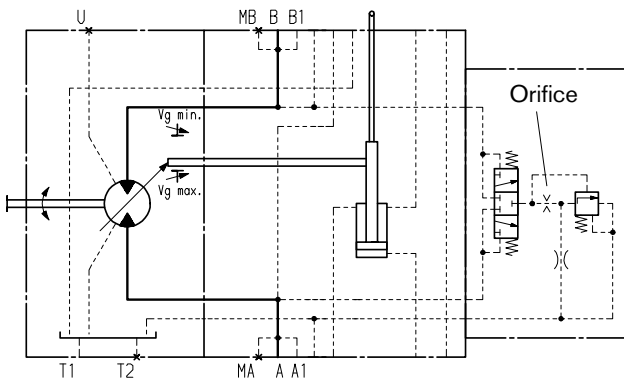

Before finalizing your design, please request a binding installation drawing. Dimensions in mm

Unit dimensions

Sizes 28 to 160

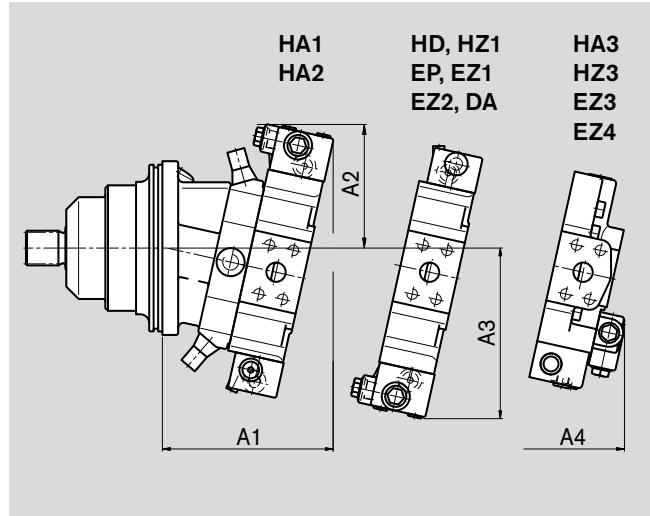

Size	A1	A2	A3	A4
28	152	125	161	-
55	182	133	176	176
80	192	141	194	176
107	203	144	200	187
160	245	154	220	-

Size 250

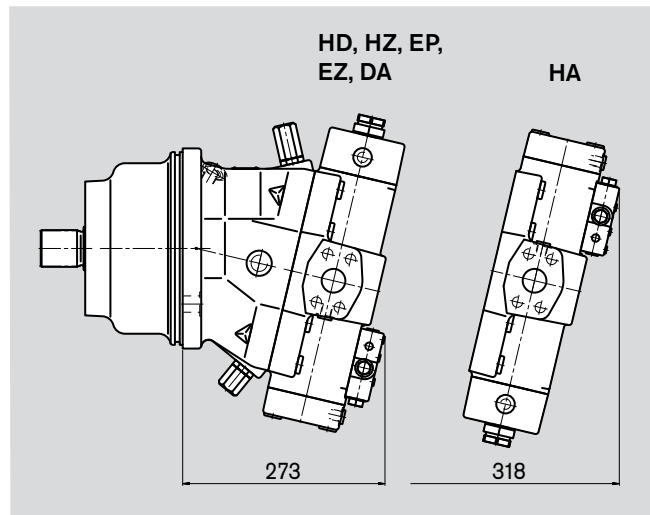

Speed Measurement

Before finalizing your design, please request a binding installation drawing. Dimensions in mm

Version "F" (sizes 55 to 160) prepared for speed measurement

The A6VE...F ("prepared for speed measurement", i.e. without sensor) versions have teeth on the rotary group. The rotating, toothed rotary group generates a signal in proportion to the speed. The signal is picked up by a sensor and can be forwarded for evaluation.

Version F is suitable for mounting to the HDD Hall-effect speed sensor (see RE 95135). The HDD sensor is flanged with two fixing screws at the specified port. In the standard version, the port is plugged with a pressure-resistant flange cover.

We recommend ordering the A6VE variable motor with mounted sensor. Please specify the ordering code for the sensor separately.

Circuit diagram

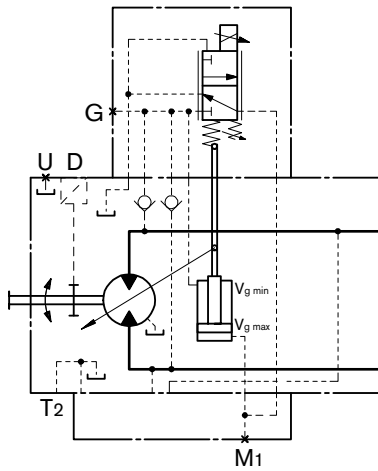

Unit dimensions

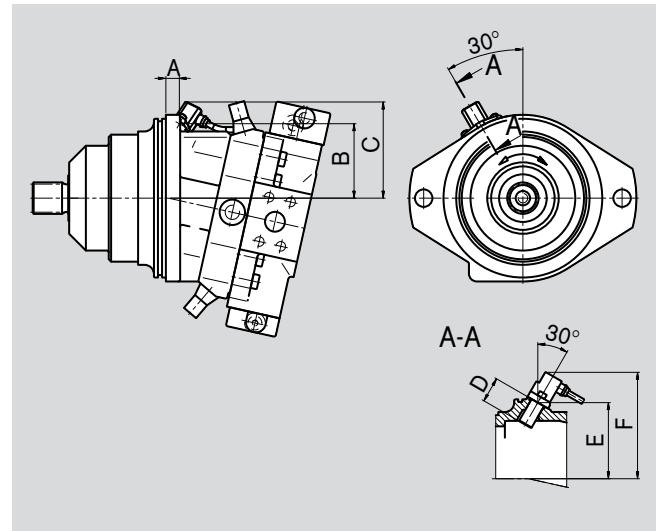

View X

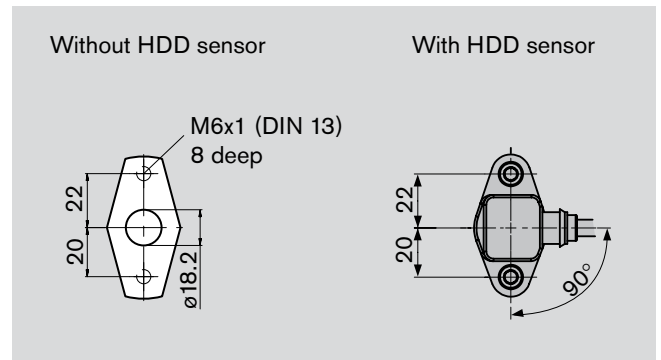

Size	55	80	107	160
Number of teeth	54	58	67	75
A	25.8	16.8	14.7	28.3
B	72.2	75.4	83.1	90.4
C	110.3	113.5	121.2	128.5
D	32	32	32	32
E	83.4±0.1	87.1±0.1	95.9±0.1	104.4±0.1
F	121.7	124.4	133.2	141.7

Suitable speed sensor: sizes 55 to 160: HDD.L32../20 (see RE 95 135)

Connectors for Solenoids

DEUTSCH DT04-2P-EP04, 2-pin

Molded, without bi-directional suppressor diode

(for EP, EZ, DA) _____ P

Type of protection according to DIN/EN 60529: IP67 and IP69K

Mating connector

DEUTSCH DT06-2S-EP04

Rexroth Mat. No. R902601804

consisting of:	DT designation
- 1 case _____	DT06-2S-EP04
- 1 wedge _____	W2S
- 2 female connectors _____	0462-201-16141

The mating connector is not included in supply.

This can be supplied by Rexroth on request.

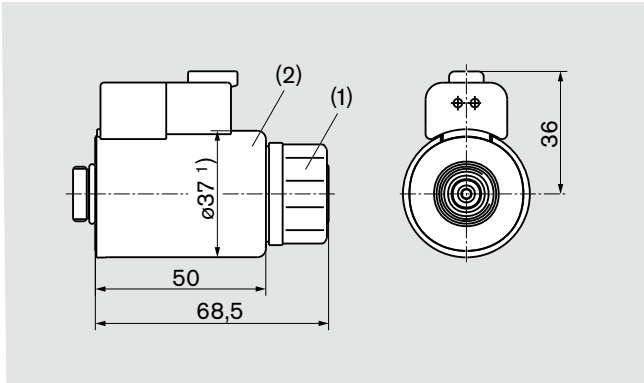

1) Solenoid with dia. 45 for following controls: EZ3, EZ4

Note for round solenoids:

The position of the connector can be changed by turning the solenoid body.

Proceed as follows:

1. Loosen the fixing nut (1)
2. Turn the solenoid body (2) to the desired position
3. Tighten the fixing nut

Tightening torque of the fixing nut: 5⁺¹ Nm
(width across flats SW26, 12-sided DIN 3124)

We reserve the right to change the position of the solenoid connector from that depicted in the brochure or drawing during assembly of the solenoid.

Installation Notes

General

During commissioning and operation, the axial piston unit must be filled with hydraulic fluid and air bled. This is also to be observed following a relatively long standstill as the system may empty via the hydraulic lines.

The motor case drain connection (i.e. T₁/T₂) must be directed to the tank via the highest case drain port.

In all operational states, the case drain line must flow into the tank below the minimum fluid level.

Installation position

See examples below. Additional installation positions are available upon request.

Below-tank installation (standard)

Motor below the minimum fluid level of the tank.

Recommended installation positions: 1 and 2.

Above-tank installation

Motor above the min. fluid level of the tank

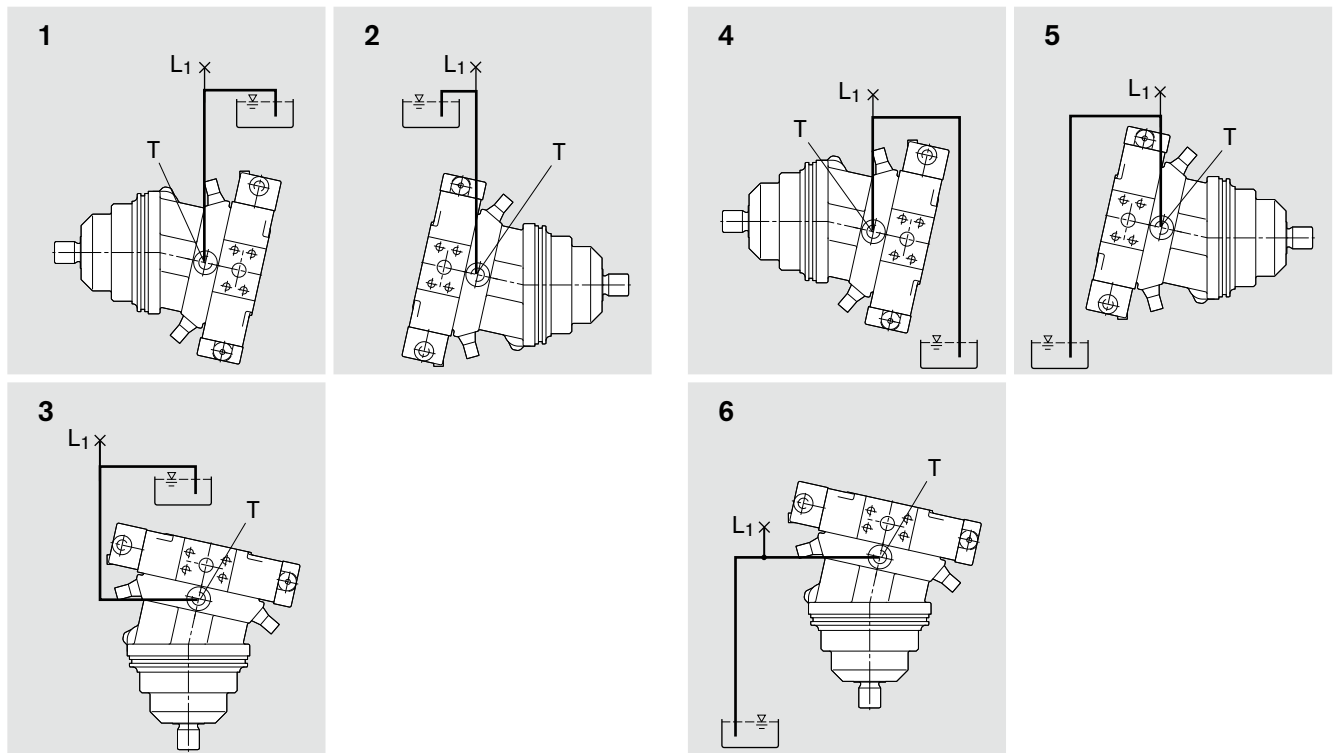

Installation position	Air bleeding	Filling
1	-	T (L ₁)
2	-	T (L ₁)
3	-	T (L ₁)

Installation position	Air bleeding	Filling
4	-	T (L ₁)
5	-	T (L ₁)
6	-	T (L ₁)

General Notes

- The A6VE motor is designed to be used in open and closed circuits.
- Project planning, assembly, and commissioning of the motor require the involvement of qualified personnel.
- The service line ports and function ports are only designed for mounting hydraulic lines.
- During and shortly after operation, there is a risk of burns on the motor and especially on the solenoids. Take suitable safety precautions, e.g. wear protective clothing
- There may be shifts in the characteristic depending on the operational state of the motor (operating pressure, fluid temperature).
- Tightening torques:
 - The tightening torques specified in this data sheet are maximum values and must not be exceeded (maximum values for screw thread).
Manufacturer's instruction for the max. permissible tightening torques of the used armatures must be observed!
 - For DIN 13 fixing screws, we recommend checking the tightening torque individually according to VDI 2230 Edition 2003.
- The data and information contained herein must be adhered to.

Bosch Rexroth AG
 Hydraulics
 Product Unit Axial Piston Units
 Elchingen Plant
 Glockeraustraße 2
 89275 Elchingen, Germany
 Phone +49 (0) 73 08 82-0
 Fax +49 (0) 73 08 72 74
 info.brm-ak@boschrexroth.de
 www.boschrexroth.com/axial-piston-motors

Horb Plant
 An den Kelterwiesen 14
 72160 Horb, Germany
 Phone +49 (0) 74 51 92-0
 Fax +49 (0) 74 51 82 21

© This document, as well as the data, specifications and other information set forth in it, are the exclusive property of Bosch Rexroth AG. It may not be reproduced or given to third parties without its consent.

The data specified above only serve to describe the product. No statements concerning a certain condition or suitability for a certain application can be derived from our information. The information given does not release the user from the obligation of own judgment and verification. It must be remembered that our products are subject to a natural process of wear and aging.

Subject to change.