

# Variable displacement pump A4VSG

**RE 92 100/11.95 1/36**  
Replaces: 01.95

## closed circuit

Sizes 40...1000  
Series 1 and 2  
Nominal pressure 350 bar  
Peak pressure 400 bar

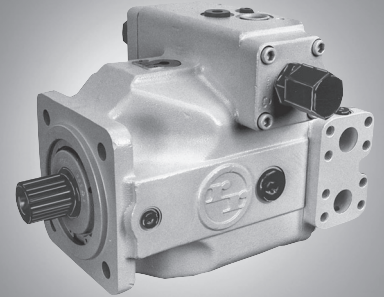

## Contents

Ordering code	2, 3
Hydraulic fluid / Mounting position	4
Technical Data	5
Unit dimensions size 40	6
Unit dimensions size 71	7
Unit dimensions size 125	8
Unit dimensions size 180	9
Unit dimensions size 250	10
Unit dimensions size 355	11
Unit dimensions size 500	12
Unit dimensions size 750	13
Unit dimensions size 1000	14
Summary controls	15, 16, 17
Through drive	18
Unit dimensions for combination pumps	19, 20
Dimensions through drive K31	20
Dimensions through drives K33 and K34	21
Dimensions through drives K35 and K77	22
Dimensions through drives K43 and K51	23
Dimensions through drives K25 and K26	24
Dimensions through drives K27 and K37	25
Dimensions through drives K59, K01 and K52	26
Dimensions through drives K02 and K04	27
Dimensions through drives K06 and K24	28
Dimensions through drives K57 and K68	29
Dimensions through drives K99, size 40...355	30
Dimensions through drives K99, size 500...1000	31
Circuit diagram with auxiliary pump, flushing block and filter	32
Unit dimensions with auxiliary pump, flushing block and filter	33
Mounted and piped auxiliary pump H02 - H05	34

## Features

The axial piston swashplate design variable displacement pump A4VSG is designed for hydrostatic transmission in closed circuit.  
Flow is proportional to input speed and displacement and is infinitely variable by adjustment of the swashplate.

- slot-controlled swashplate design
- infinitely variable adjustment of displacement
- reversible flow
- permissible nominal pressure 350 bar
- low noise level
- long service life
- drive shaft capable of absorbing axial and radial loads
- high power/weight ratio
- modular design
- short control times
- through drive and tandem pumps possible
- pump swivel angle indicator
- installation position optional
- operation on HF fluids possible with reduced operating parameters

For description of control and regulating devices see separate RE sheets

RE 92055, RE 92060, RE 92064  
RE 92072, RE 92076, RE 92080

## Ordering code

### Fluid

Mineral oils (no short code)	
HF fluids (except Skydrol)	E-

### Axial piston unit

Variable pump, swashplate design, for industrial drives	A4VS
---------------------------------------------------------	------

### Operating mode

Pump, closed circuit	G
----------------------	---

### Size

≅ Displacement $V_{g,max}$ (cm <sup>3</sup> )	40	71	125	180	250	355	500	750	1000
-----------------------------------------------	----	----	-----	-----	-----	-----	-----	-----	------

### Control device

Manual control	MA	●	●	●	●	●	●	●	-	-	MA	} see RE 92072
Electric motor control	EM	●	●	●	●	●	●	●	-	-	EM..	
Hydraulic control, flow dependent	HM	●	●	●	●	●	●	●	○	○	HM..	} see RE 92076
Hydr. control with servo/ prop. valve	HS	●	●	●	●	●	●	●	●	●	HS..	
Electronic control	EO	●	●	●	●	●	●	●	○	○	EO..	} see RE 92080
Hydr. control, pressure dependent	HD <sup>1)</sup>	●	●	●	●	●	●	●	●	○	HD..	
Press. control, single sided operation	DR <sup>1)</sup>	●	●	●	●	●	●	●	●	○	DR..	see RE 92060
Power control with hyperbolic curve	LR <sup>1)</sup>	●	●	●	●	●	●	●	●	○	LR..N	see RE 92064
Hydr. control, distance dependent	HW	●	●	●	●	●	●	●	●	○	HW	see RE 92068
Speed control, secondary control	DS	●	●	●	●	●	●	●	●	○	DS..	see RE 92055

### Series

	●	●	-	-	-	-	-	-	-	-	10
	-	-	●	●	●	●	●	●	●	●	22

### Direction of rotation

Viewed on shaft end	right	R
	left	L
	bi-directional	W <sup>1)</sup>

### Seals

NBR (Nitrile rubber to DIN ISO 1629) with shaft seal FPM	P
FPM (Fluoride rubber to DIN ISO 1629)	V

### Shaft end

Parallel with key to DIN 6885	P
Splined to DIN 5480	Z

### Mounting flange

	40	71	125	180	250	355	500	750	1000	
ISO 4-hole	●	●	●	●	●	●	-	-	-	B
ISO 8-hole	-	-	-	-	-	-	●	●	●	H

### Service ports

Ports A,B: SAE at the side (same side), with metric fixing screws	10
-------------------------------------------------------------------	----

### Through drive / tandem pump

- If a **second Brueninghaus pump is factory mounted**, both ordering codes must be combined with "+".  
 Ordering code 1st pump + ordering code 2nd pump  
**Ordering example:** A4VSG 125 EO1/22R – PPB10K339F + A4VSG 71 HM1/10R – PZB10N000N
- If a **gear pump or radial piston pump is factory mounted**, please consult us.

<sup>1)</sup> Bi-directional rotation not always possible, please note separate RE sheets.

<sup>2)</sup> Size 500 only available for DS control, for HS/HS1 see RE 92076

● = available      ○ = in preparation      - = not available

	<b>A4VS</b>	<b>G</b>			<b>/</b>		<b>-</b>			<b>10</b>			
--	-------------	----------	--	--	----------	--	----------	--	--	-----------	--	--	--

- Fluid
- Axial piston unit
- Operating mode
- Size
- Control device
- Model
- Direction of rotation
- Seals
- Shaft end
- Mounting flange
- Service ports

**Through drive**

			40	71	125	180	250	355	500	750	1000	
Without through drive			●	●	●	●	●	●	●	●	●	N00
With through drive <sup>1)</sup> for mounting of axial piston unit, gear pump or radial piston pump												
Flange	Hub/Shaft	to accept										
ISO 125, 4-hole	Splined shaft 32x2x30x14x9g	A4VSO/H/G 40	●	●	●	●	●	○	●	○	○	K31
ISO 140, 4-hole	Splined shaft 40x2x30x18x9g	A4VSO/H/G 71	-	●	●	●	●	●	●	○	○	K33
ISO 160, 4-hole	Splined shaft 50x2x30x24x9g	A4VSO/H/G 125	-	-	●	●	●	○	●	○	○	K34
ISO 160, 4-hole	Splined shaft 50x2x30x24x9g	A4VSO/G 180	-	-	-	●	●	○	●	○	○	K34
ISO 224, 4-hole	Splined shaft 60x2x30x28x9g	A4VSO/H/G 250	-	-	-	-	●	○	●	○	○	K35
ISO 224, 4-hole	Splined shaft 70x3x30x22x9g	A4VSO/G 355	-	-	-	-	-	●	○	○	○	K77
ISO 315, 8-hole	Splined shaft 80x3x30x25x9g	A4VSO/G 500	-	-	-	-	-	-	●	●	○	K43
ISO 400, 8-hole	Splined shaft 90x3x30x28x9g	A4VSO/G 750	-	-	-	-	-	-	-	○	○	K76
ISO 80, 2-hole	Keyed shaft 18 mm dia.	A10VSO 18	●	●	●	●	●	●	●	○	○	K51
ISO 100, 2-hole	Keyed shaft 22 mm dia.	A10VSO 28	●	●	●	●	●	○	○	○	○	K25
ISO 100, 2-hole	Keyed shaft 25 mm dia.	A10VSO 45	●	●	●	●	●	○	○	○	○	K26
ISO 125, 2-hole	Keyed shaft 32 mm dia.	A10VSO 71	-	●	●	●	●	●	●	○	○	K27
ISO 125, 2-hole	Keyed shaft 40 mm dia.	A10VSO 100	-	-	●	●	●	○	●	○	○	K37
ISO 180, 4-hole	Keyed shaft 45 mm dia.	A10VSO 140	-	-	-	○	●	●	●	○	○	K59
82-2 (SAE A, 2-hole)	Splined shaft 5/8" 16-4 (SAE A)	G2 / GC2/GC3-1X	●	●	●	●	●	●	●	○	○	K01
82-2 (SAE A, 2-hole)	Splined shaft 3/4" 19-4 (SAE A-B)	A10VSO 18	●	●	●	●	●	●	●	○	○	K52
101-2 (SAE B, 2-hole)	Splined shaft 7/8"	G3, A10VO 28	●	●	●	●	●	●	●	●	○	K02
101-2 (SAE B)	Splined shaft 25-4 (SAE B-B)	GC4-1X, A10VO 45	○	○	●	○	○	●	○	○	○	K04
101-2 (SAE B)	Splined shaft 32-4 (SAE C)	GC5-1X	○	●	●	○	●	○	○	○	○	K06
127-2 (SAE C)	Splined shaft 32-4 (SAE C)	A10VO 71	-	○	○	○	○	○	○	○	○	K07
127-2 (SAE C)	Splined shaft 38-4 (SAE C-C)	GC6-1X, A10VO 100	-	-	●	●	●	○	○	○	○	K24
152-4 (SAE D)	Splined shaft 44-4 (SAE D)	A10VO 140	-	-	-	○	○	○	○	○	○	K17
63 mm dia. metric, 4-hole	Keyed shaft 25 mm dia.	R4	●	●	●	○	●	○	○	○	○	K57
101-2 (SAE B)	22-4 (SAE B)	G4	●	●	●	●	●	●	●	●	○	K68
With through drive, without hub or intermediate flange, with cover closed			●	●	●	●	●	●	●	●	●	K99

**Auxiliary pump mounted and piped to boost circuit filter**

1 auxiliary pump for boost oil circuit	n < 2800 rpm	-	●	●	●	●	●	●	○	○	H02
	n > 2800 rpm	●	●	-	-	-	-	-	-	-	H03
1 auxiliary pump for boost and pilot oil circuits combined (only for EO1)	n < 2800 rpm	-	●	●	-	●	-	-	-	-	H04
	n > 2800 rpm	●	●	-	-	-	-	-	-	-	H05

For mounted auxiliary pumps see RE 90139 (in preparation)

**Valves**

Without valve block	0
Valve block SDVB mounted	9

**Filtration**

Without filter	●	●	●	●	●	●	●	●	●	●	N
Filter in boost circuit, mounted	●	●	●	●	●	●	●	○	○		F
Sandwich plate filter for HS and DS control (see RE 92076 and RE 92055)	●	●	●	●	●	●	● <sup>2)</sup>	-	-		Z
Filter in boost circuit mounted and sandwich plate filter for HS and DS controls	●	●	●	●	●	●	● <sup>2)</sup>	-	-		U

## Fluid

For extensive information on the selection of fluids and for application conditions, please consult our data sheets RE 90220 (mineral oils), RE 90221 (environmentally acceptable fluids) or RE 90223 (HF fluids) before proceeding with the design stage. When operating with environmentally acceptable or HF fluids reduced operating conditions may apply.

### Operating viscosity range

In order to obtain optimum efficiency and service life, we recommend that the operating viscosity (at operating temperature) be selected from within the range:

$$v_{opt} = \text{operating viscosity } 16...36 \text{ mm}^2/\text{s}$$

referred to the closed loop temperature.

### Viscosity limits

The limiting values for viscosity are as follows:

$v_{min} = 10 \text{ mm}^2/\text{s}$   
short term at a maximum permissible drain temperature of 90° C.

$v_{max} = 1000 \text{ mm}^2/\text{s}$   
short term on cold start.

### Notes on the selection of hydraulic fluid

In order to select the correct fluid, it is necessary to know the operating temperature in the circuit (closed loop), in relation to the ambient temperature.

The hydraulic fluid should be selected so that within the operating temperature range the operating viscosity lies within the optimum range ( $n_{opt}$ ), (see shaded section of selection diagram). We recommend that the highest possible viscosity range be chosen in each case.

### Selection diagram

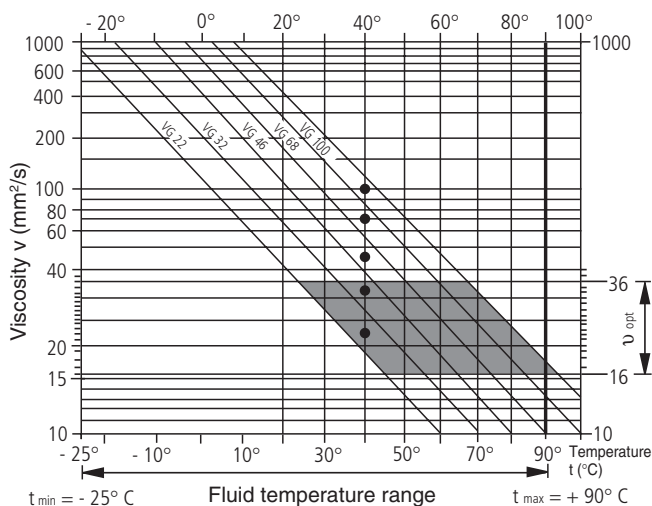

Example: At an ambient temperature of X° C the operating temperature is 60° C. Within the optimum operating viscosity range ( $n_{opt}$ ; shaded area) this corresponds to viscosity ranges VG 46 or VG 68. VG 68 should be selected.

Important: The leakage oil (case drain oil) temperature is influenced by pressure and speed and is always higher than the circuit temperature. However at no point in the circuit may the temperature exceed 90° C.

If it is not possible to comply with the above conditions because of extreme operating parameters or high ambient temperatures, please consult us.

### Flushing of the bearings

With the following operating conditions the bearings should be flushed to ensure correct functioning over a long period:

- with special fluids (not mineral) due to limited lubricity and a narrow operating temperature range
- when operating with mineral oils in limited conditions of temperature and viscosity
- with vertical installation (drive shaft facing upwards) flushing of the bearings is recommended for lubrication of the front bearing and shaft sealing ring.

Flushing of the bearings is carried out via port "U" in the vicinity of the front flange of the variable pump. The flushing oil flows through the front bearing and out with the pump case drain oil at the drain port.

The following quantities are required for flushing the various sizes:

Size	40	71	125	180	250	355	500	750	1000
$Q_{sp}$ L/min	3	4	5	7	10	15	20	30	40

For the given flushing quantities there will be a pressure difference of approx. 2 bar between port "U" (including fittings) and the case drain oil chamber.

### Filtration of fluid (axial piston unit)

In order to ensure correct functioning of the unit, a minimum level of cleanliness to NAS 16389 class 9

SAE class 6

ISO/DIS 4406 class 18/15 is necessary.

This is achievable for example with a filter element

Type...D 020...(see RE 31278).

This gives a filter quotient of

$$\beta_{20} \geq 100$$

If a filter for the boost circuit is factory mounted (Ordering code **F**), depending on the size of the axial piston unit the following filters are installed, fitted with opto-electrical clogging indicator as standard:

- Sizes 40 and 71: LFBN/HC60G20D1.0/24/V
- Sizes 125, 180 and 250: LFBN/HC110G20D1.0/24/V
- Size 355: LFBN/HC240G20D1.0/L24/V
- Size 500: LFBN/HC330G20D1.0/L24/V

For further details see RE 31278.

### Temperature range (cf. selection diagram)

$t_{min} = -25^\circ \text{C}$

$t_{max} = +90^\circ \text{C}$

## Installation instructions

### Installation position:

Optional. The pump housing must be filled with hydraulic fluid when commissioning and during operation.

In order to minimise noise levels, all connecting piping (suction, pressure, case drain oil ports) must be disconnected from the tank by means of flexible elements.

The use of check valves in the case drain oil line is to be avoided. They, however, may be used in certain cases after consultation with us.

### Technical data

(applicable for operation with mineral oils)

#### Operating pressure range - inlet side

Recommended boost pressure  $p_{Sp}$  \_\_\_\_\_ 16 bar  
 Recommended boost pressure with common auxiliary pump for boost and pilot oil circuits (EO1)  $p_{Sp}$  \_\_\_\_\_ 25 bar

Maximum boost pressure – auxiliary pump max. pressure  $P_{Hmax}$  for MA-, EM-, HM-, HS-, EO-, DS-settings \_\_\_\_\_ 50 bar  
 for HD-, HW-settings and LR.N- and DR-control \_\_\_\_\_ 16 bar

Auxiliary pumps - inlet pressure  
 Suction pressure  $p_{smin}$  ( $v = 10...300 \text{ mm}^2/\text{s}$ )  $\geq 0,7$  bar absolute

#### Operating pressure range - outlet side

(pressures to DIN 24312)  
 Pressure at port A or B  
 Nominal pressure  $p_N$  \_\_\_\_\_ 350 bar  
 Peak pressure  $p_{max}$  \_\_\_\_\_ 400 bar

#### Case drain pressure

The maximum permissible case drain pressure (housing pressure) is dependent on speed (see diagram).

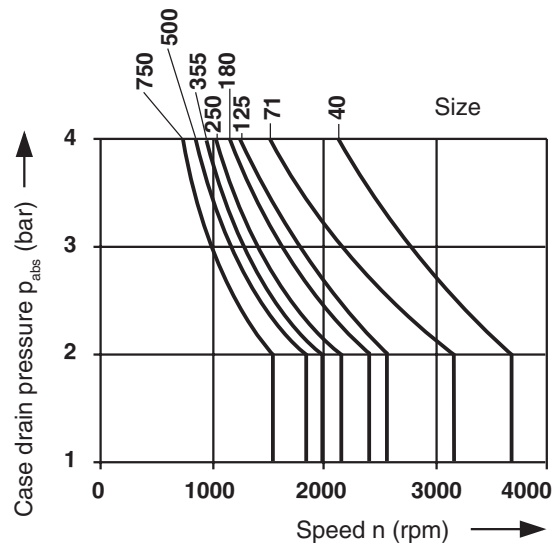

Max. case drain pressure (housing pressure)  
 $P_{Lmax}$  \_\_\_\_\_ 4 bar  
 These are approximate values. Under certain operating conditions a reduction in these values may be necessary.

**Table of values** (theoretical values, without considering  $\eta_{mh}$  and  $\eta_v$ ; values rounded)

Size		40	71	125	180	250	355	500	750	1000	
Displacement	$V_{gmax}$ cm <sup>3</sup>	40	71	125	180	250	355	500	750	1000	
Max. speed	$n_{max}$ rpm	3700	3200	2600	2400	2200	2000	1800	1600	1600	
Max. flow	at $n_{max}$	$Q_{max}$ L/min	148	227	325	432	550	710	900	1200	1600
	at $n_E = 1500$ rpm	L/min	60	107	186	270	375	533	750	1125	1500
Max. power ( $\Delta p = 350$ bar)	at $n_{o,max}$	$P_{o,max}$ kW	86	132	190	252	321	414	525	700	933
	at $n_E = 1500$ rpm	kW	35	62	109	158	219	311	438	656	875
Max. torque ( $\Delta p = 350$ bar)	at $V_{gmax}$	$T_{max}$ Nm	223	395	696	1002	1391	1976	2783	4174	5565
Torque ( $\Delta p = 100$ bar)	at $V_{gmax}$	T Nm	64	113	199	286	398	564	795	1193	1590
Moment of inertia about drive axis	J	kgm <sup>2</sup>	0,0049	0,0121	0,03	0,055	0,0959	0,19	0,3325	0,66	1,20
Filling volume	L	2	2,5	5	4	10	8	14	19	27	
Approx. weight (pump with EO1 control and valve block)	m kg	47	60	100	114	214	237	350	500	630	
Max. axial force	$\pm F_{ax,max}$ N	600	800	1000	1400	1800	2000	2000	2200	2200	
Max. radial force	$F_{q,max}$ N	1000	1200	1600	2000	2000	2200	2500	3000	3500	

#### Determination of size

Output flow  $Q = \frac{V_g \cdot n \cdot \eta_v}{1000}$  [L/min]

Torque  $T = \frac{1,59 \cdot V_g \cdot \Delta p}{100 \cdot \eta_{mh}}$  [Nm]

Power  $P = \frac{2\pi \cdot T \cdot n}{60000} = \frac{T \cdot n}{9549} = \frac{Q \cdot \Delta p}{600 \cdot \eta_t}$  [kW]

- $V_g$  = geometr. displacement [cm<sup>3</sup>] per revolution
- $\Delta p$  = Differential pressure [bar]
- $n$  = Speed [rpm]
- $\eta_v$  = Volumetric efficiency
- $\eta_{mh}$  = Mechanical-hydraulic efficiency
- $\eta_t$  = Total efficiency [ $\eta_t = \eta_v \cdot \eta_{mh}$ ]

#### Application of forces

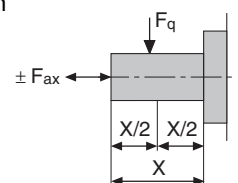

Before finalising your design, please request a certified drawing.  
All rights reserved, subject to revision.

## Unit dimensions Size 40

(not including control)

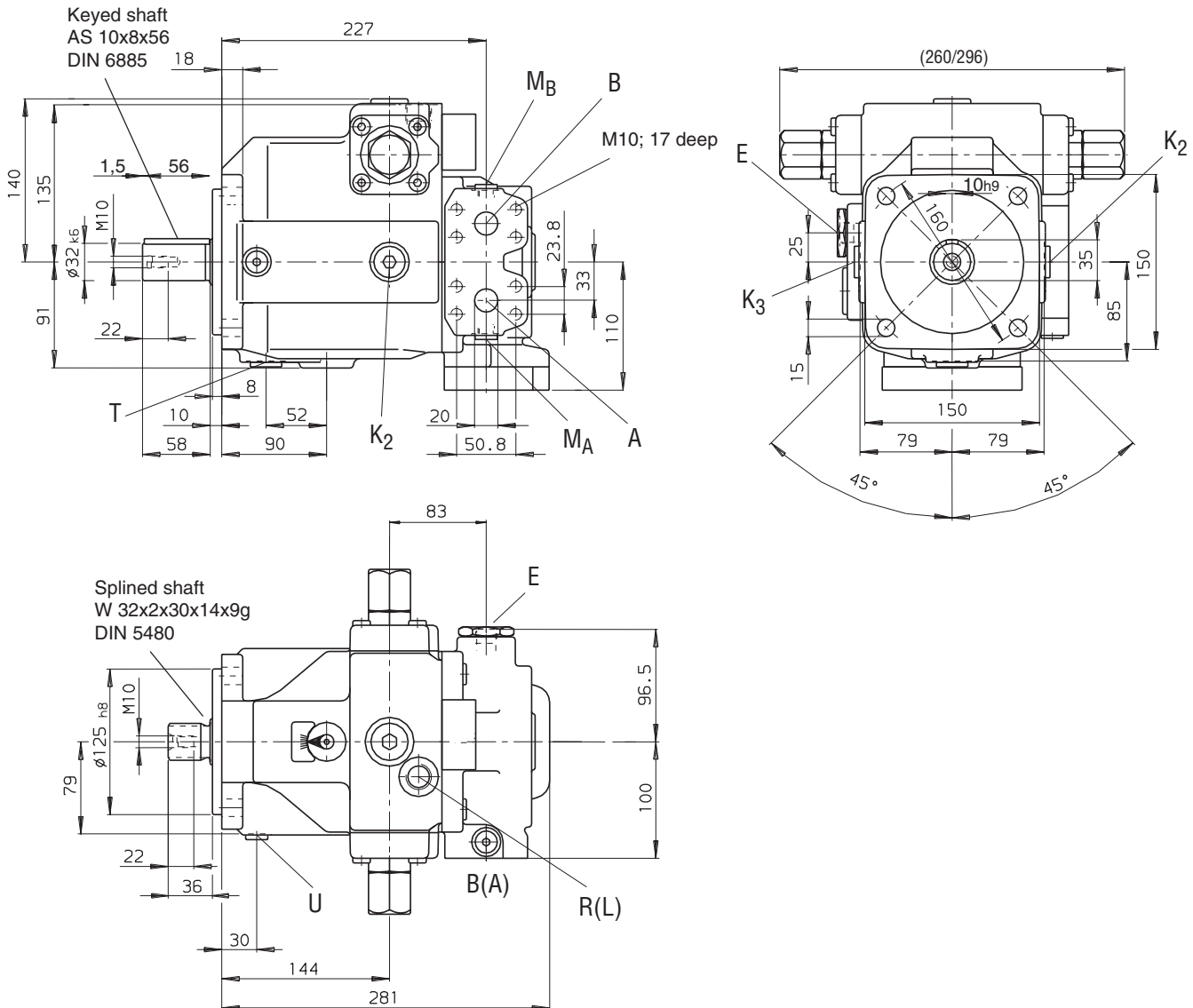

### Ports

A, B	Pressure ports	SAE 3/4" (high pressure range)
M <sub>A</sub> , M <sub>B</sub>	Gauge ports	M14x1,5 (plugged)
T	Oil drain	M22x1,5 (plugged)
E	Boost port	M18x1,5
K <sub>2</sub> , K <sub>3</sub>	Housing flushing ports	M22x1,5 (plugged)
R(L)	Oil filling + bleeding ports	M22x1,5;
	For exact position see spec. for relevant control device	
U	Flushing port	M14x1,5;12 deep (plugged)

Before finalising your design, please request a certified drawing.  
All rights reserved, subject to revision.

## Unit dimensions Size 71

(not including control)

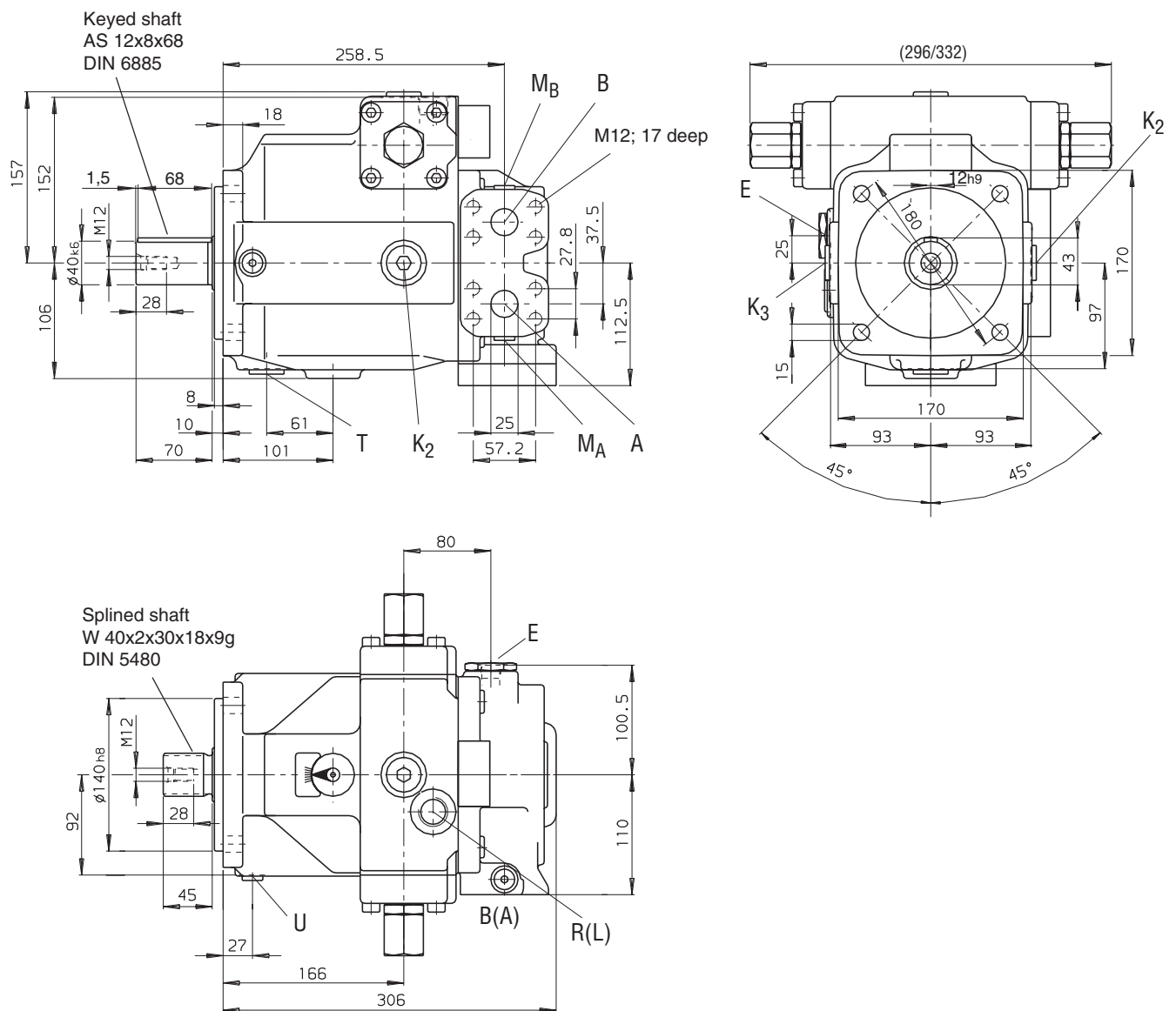

### Connections

A, B	Pressure ports	SAE 1" (high pressure range)
M <sub>A</sub> , M <sub>B</sub>	Gauge ports	M14x1,5 (plugged)
T	Oil drain	M27x2 (plugged)
E	Boost port	M18x1,5
K <sub>2</sub> , K <sub>3</sub>	Housing flushing ports	M27x2 (plugged)
R(L)	Oil filling + bleeding ports	M27x2;
	For exact position see spec. for relevant control device	
U	Flushing port	M14x1,5; 12 deep (plugged)

Before finalising your design, please request a certified drawing.  
All rights reserved, subject to revision.

## Unit dimensions Size 125

(not including control)

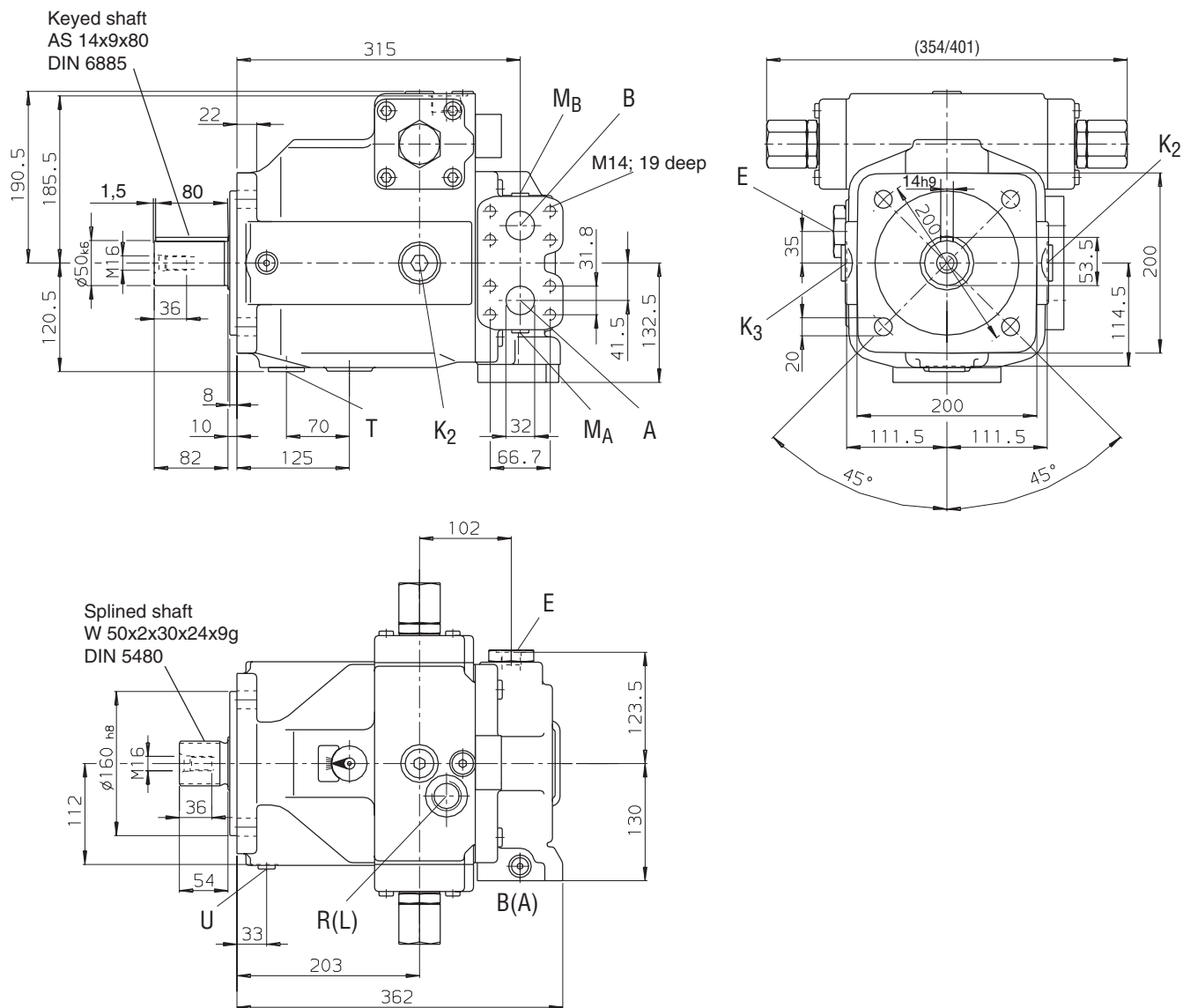

### Connections

A, B	Pressure ports	SAE 1 1/4" (high pressure range)
M <sub>A</sub> , M <sub>B</sub>	Gauge ports	M14x1,5 (plugged)
T	Oil drain	M33x2 (plugged)
E	Boost port	M22x1,5
K <sub>2</sub> , K <sub>3</sub>	Housing flushing ports	M33x2 (plugged)
R(L)	Oil filling + bleeding ports	M33x2;
	For exact position see spec. for relevant control device	
U	Flushing port	M14x1,5; 12 deep (plugged)

Before finalising your design, please request a certified drawing.  
All rights reserved, subject to revision.

## Unit dimensions Size 180

(not including control)

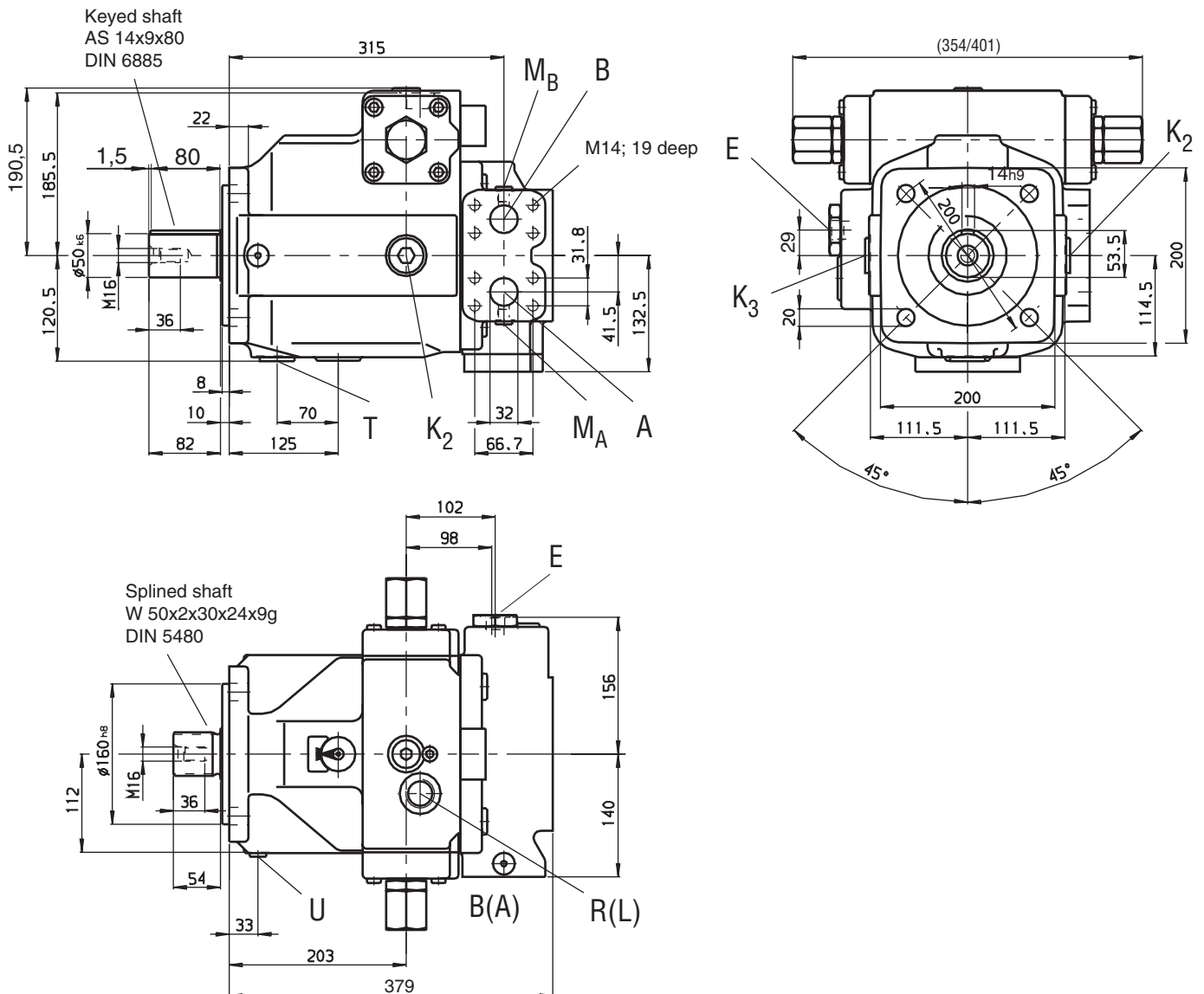

### Connections

A, B	Pressure ports	SAE 1 1/4" (high pressure range)
$M_A, M_B$	Gauge ports	M14x1,5 (plugged)
T	Oil drain	M33x2 (plugged)
E	Boost port	M22x1,5
$K_2, K_3$	Housing flushing ports	M33x2 (plugged)
R(L)	Oil filling + bleeding ports	M33x2;
	For exact position see spec. for relevant control device	
U	Flushing port	M14x1,5;12 deep (plugged)



Before finalising your design, please request a certified drawing.  
All rights reserved, subject to revision.

## Unit dimensions Size 355

(not including control)

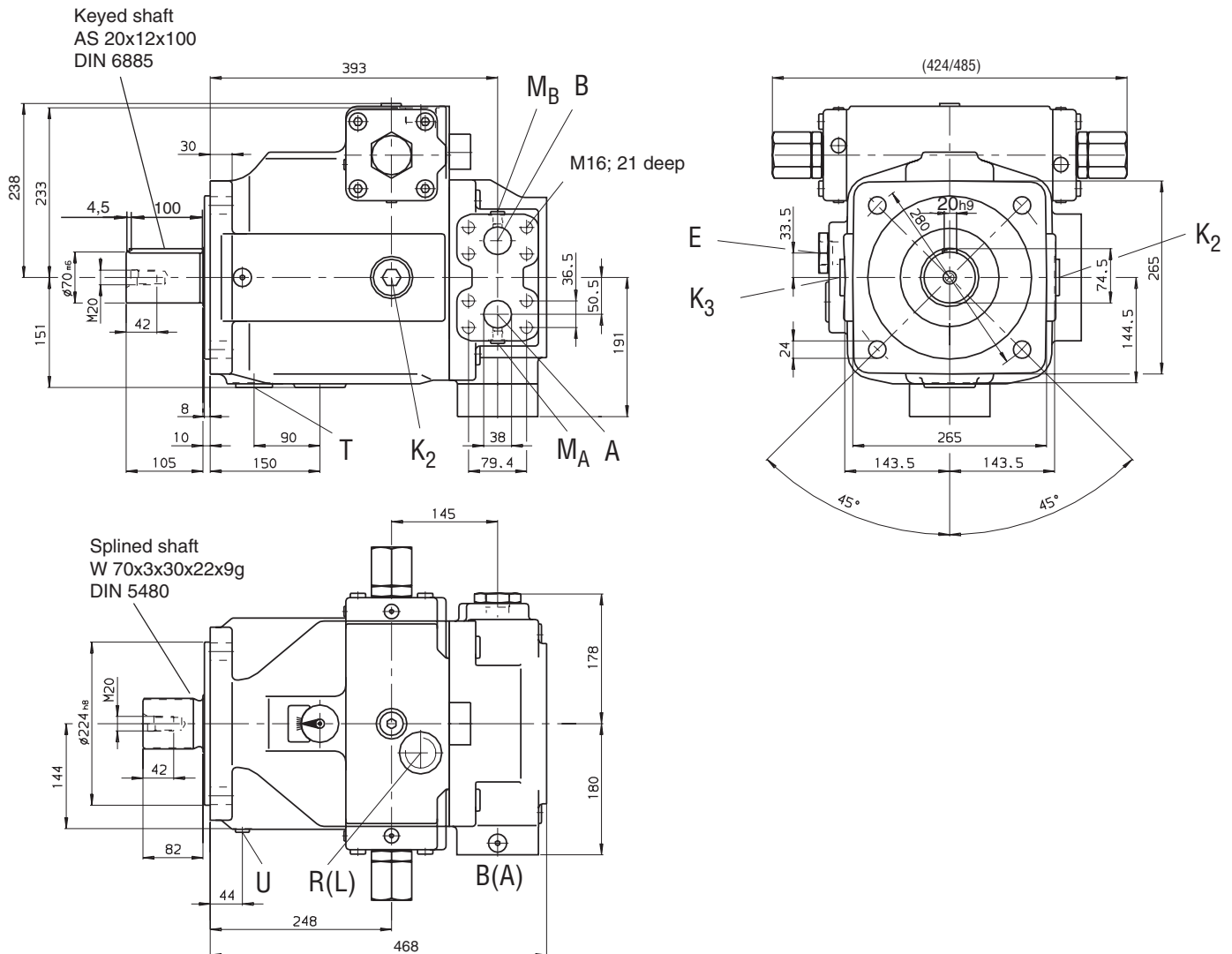

### Connections

A, B	Pressure ports	SAE 1 1/2" (high pressure range)
M <sub>A</sub> , M <sub>B</sub>	Gauge ports	M14x1,5 (plugged)
T	Oil drain	M42x2 (plugged)
E	Boost port	M33x2
K <sub>2</sub> , K <sub>3</sub>	Housing flushing ports	M42x2 (plugged)
R(L)	Oil filling + bleeding ports	M42x2;
	For exact position see spec. for relevant control device	
U	Flushing port	M18x1,5;12 deep (plugged)

Before finalising your design, please request a certified drawing.  
All rights reserved, subject to revision.

### Unit dimensions Size 500

(not including control)

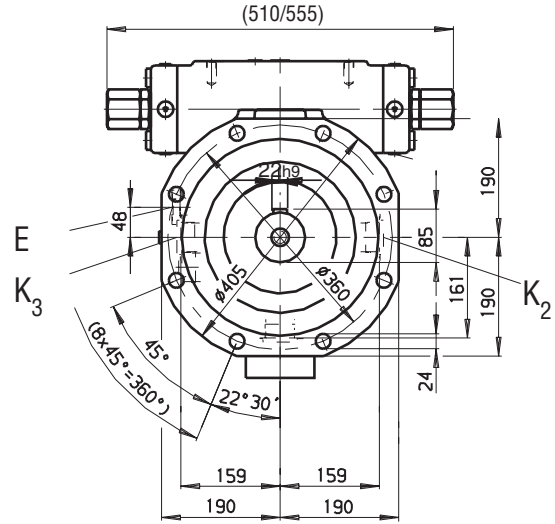
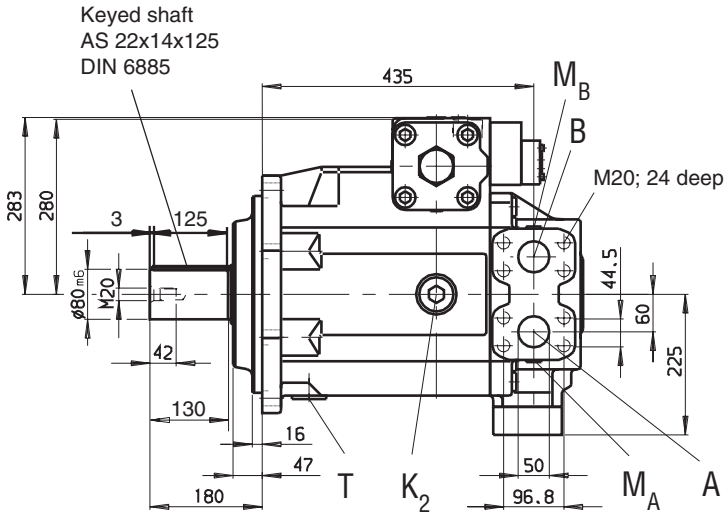

M 16 DIN 580, 27 deep  
Ring bolt for handling

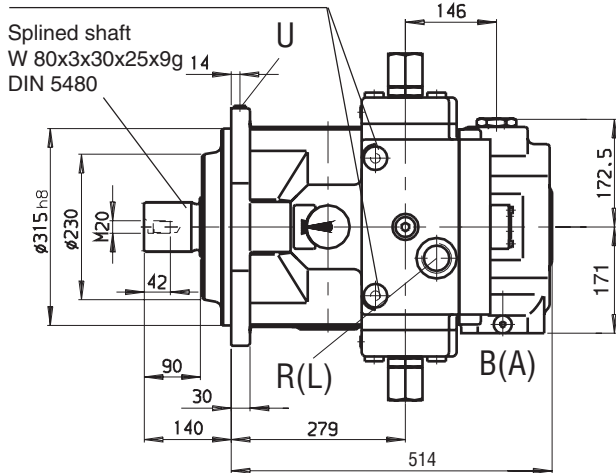

#### Connections

- |                                 |                                                             |                              |
|---------------------------------|-------------------------------------------------------------|------------------------------|
| A, B                            | Pressure ports                                              | SAE 2" (high pressure range) |
| M <sub>A</sub> , M <sub>B</sub> | Gauge ports                                                 | M18x1,5 (plugged)            |
| T                               | Oil drain                                                   | M48x2 (plugged)              |
| E                               | Boost port                                                  | M33x2                        |
| K <sub>2</sub> , K <sub>3</sub> | Housing flushing ports                                      | M48x2 (plugged)              |
| R(L)                            | Oil filling + bleeding ports                                | M48x2;                       |
|                                 | For exact position see spec.<br>for relevant control device |                              |
| U                               | Flushing port                                               | M18x1,5; 12 deep (plugged)   |

Before finalising your design, please request a certified drawing.  
All rights reserved, subject to revision.

### Unit dimensions Size 750

(not including control)

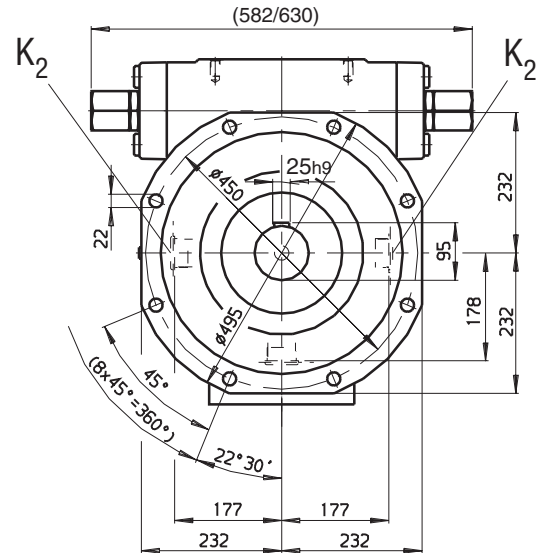
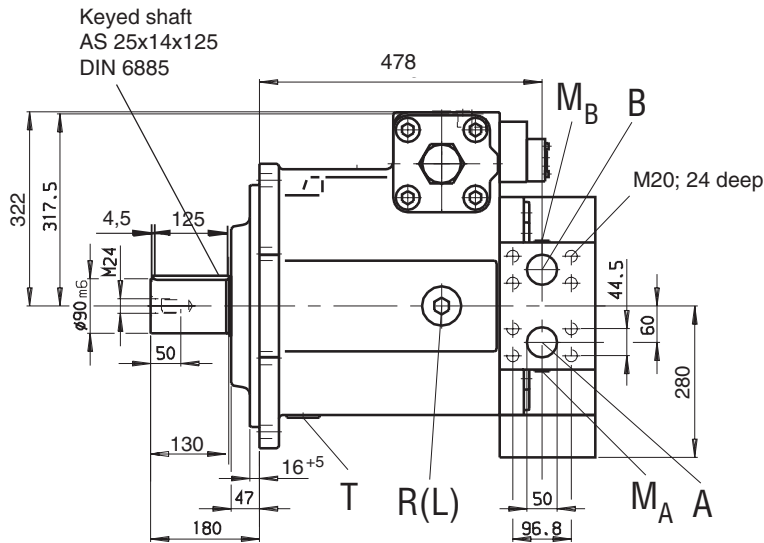

M 16 DIN 580, 27 deep  
Ring bolt for handling

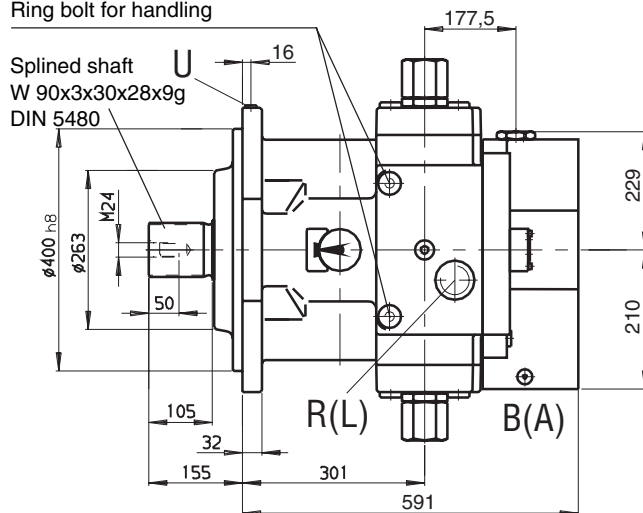

#### Connections

A, B	Pressure ports	SAE 2" (high pressure range)
M <sub>A</sub> , M <sub>B</sub>	Gauge ports	M18x1,5 (plugged)
T	Oil drain	M48x2 (plugged)
E	Boost port	M48x2
K <sub>2</sub> , K <sub>3</sub>	Housing flushing ports	M48x2 (plugged)
R(L)	Oil filling + bleeding ports	M48x2;
	For exact position see spec. for relevant control device	
U	Flushing port	M18x1,5;12 deep (plugged)



## Summary controls

### Manual control MA

Stepless adjustment of displacement by means of handwheel.

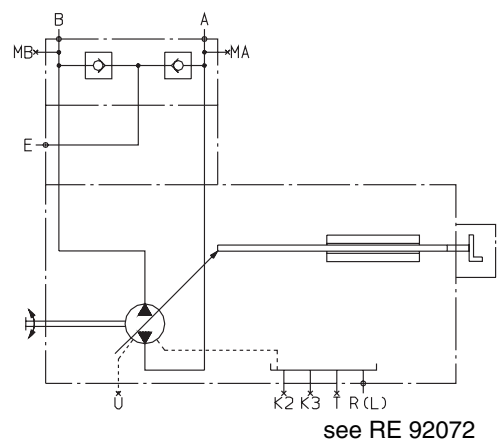
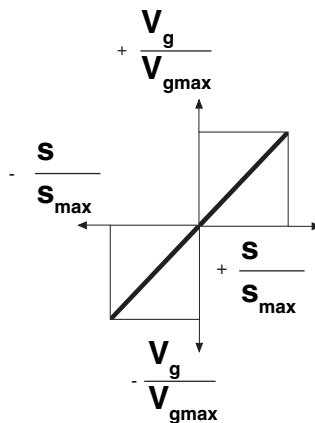

see RE 92072

### Electric motor control EM

Stepless adjustment of displacement by means of electric motor with control spindle. With a programmed sequence control various intermediate displacements can be selected by means of built-on limit switches or potentiometer.

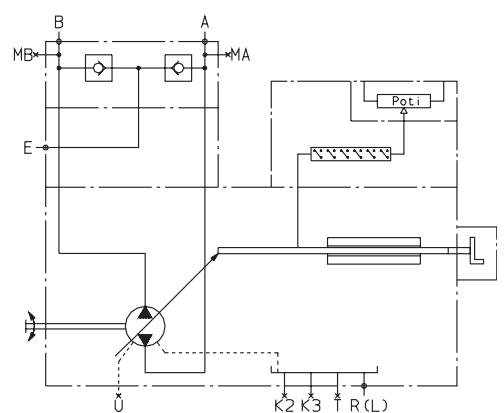
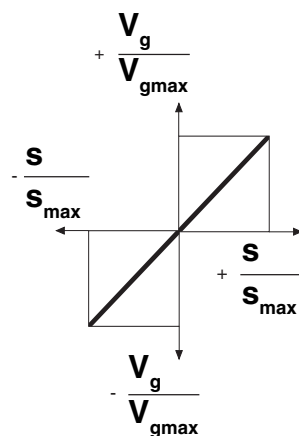

see RE 92072

### Hydraulic control HD pilot pressure dependent

Stepless adjustment of pump displacement dependent on pilot pressure. The displacement is proportional to the pilot pressure.

Optional:

- Pilot characteristics (HD1, HD2, HD3)
- Pressure control (HD.A, HD.B, HD.D)
- Remote pressure control (HD.GA, HD.GB, HD.G)
- Power control (HD1P)
- Electr. pilot pressure control (HD1T)

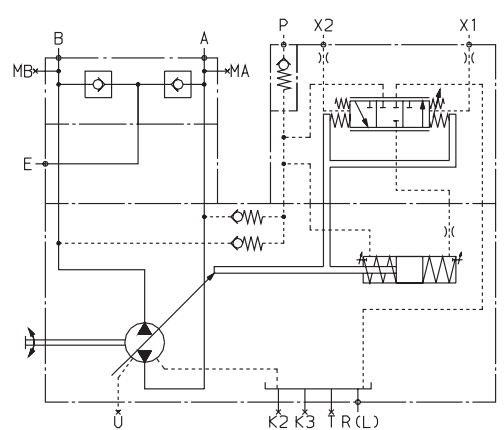
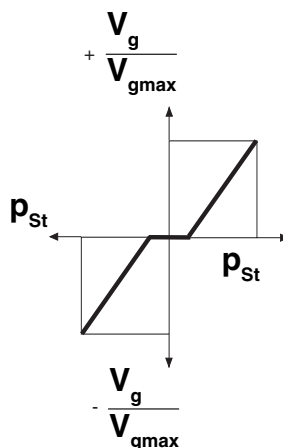

see RE 92080

### Hydraulic control HW path dependent

Stepless adjustment of pump displacement proportional to sine  $\beta$  of the angle of the control lever.

Optional:

- with hyperbolic power control (HWP)
- for single sided operation

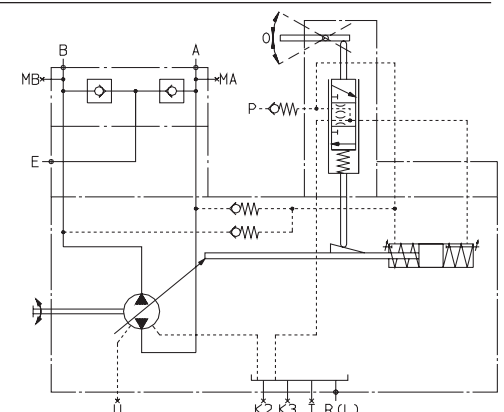
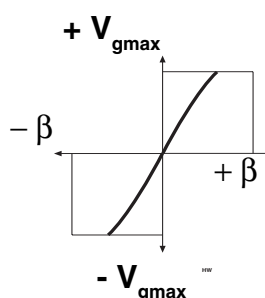

see RE 92068 (in prep.)

**Hydraulic displacement control HM 1/2/3 control volume dependent**

The displacement volume of the pump is infinitely adjustable, depending on the control volume in ports X<sub>1</sub> and X<sub>2</sub>.  
 Application: - 2 point control  
 - basic control device for servo or proportional control

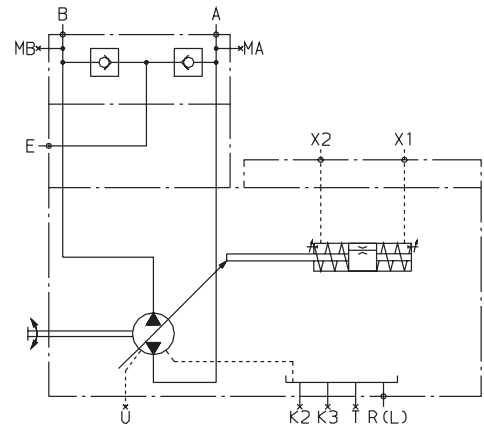

(e.g. HM1) see RE 92076

**Hydraulic displacement control EO 1/2**

Stepless adjustment of displacement is achieved by means of a proportional valve with electrical feedback of swivel angle.  
**Electronic control**  
 Optional:  
 Short circuit valve (EO1K, EO2K)  
 Without valve (EO1E, EO2E)

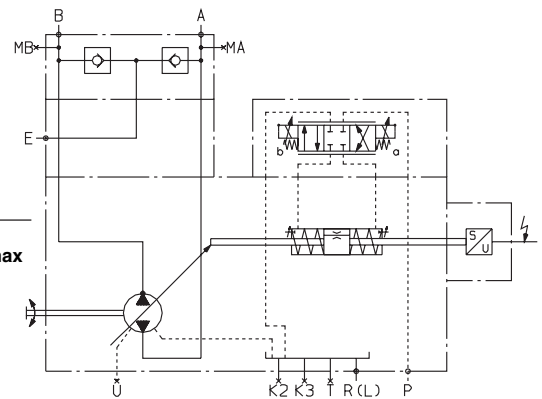
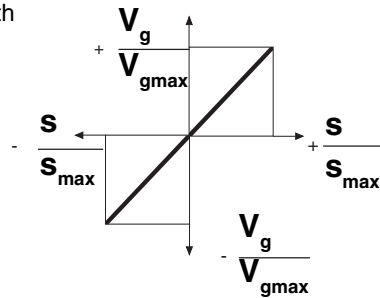

see RE 92076

**Hydraulic displacement control HS, HS1, HS3 with servo or proportional valve**

Stepless adjustment of displacement is achieved by means of a servo or proportional valve with electrical feedback of swivel angle.  
**Electronic control**  
 Optional: Servo valve (HS/ HS1), proportional valve (HS3), short circuit valve (HS1K, HS3K), without valve (HSE, HS1E, HS3E). The **HS3P** control is fitted with a built-on pressure transducer for additional **electr. adjustable pressure and power control**.

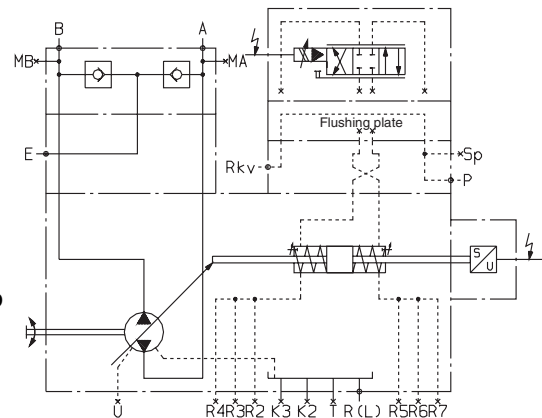
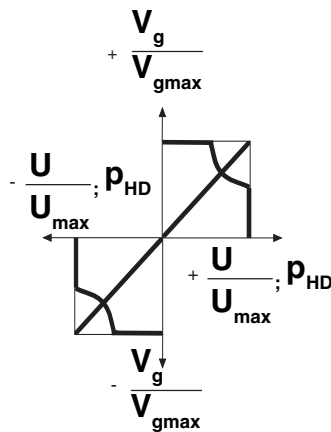

(e.g. HS) see RE 92076

**Speed control DS1 secondary controlled**

Speed control DS1 controls the secondary unit (the motor) in such a way that this motor supplies sufficient torque to maintain the required speed. Connected up to a system with constant pressure, this torque is proportional to displacement and thus also to the swivel angle.

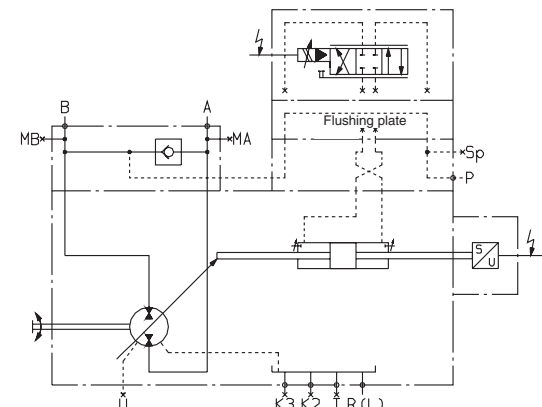
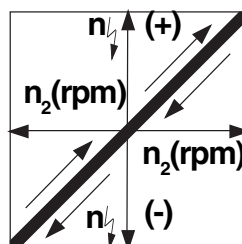

see RE 92055

## Summary controls

### Hydraulic control LR.N

pilot pressure dependent initial position  $V_{g\ min}$

Single sided operation

With overriding power control.

Displacement is proportional to pilot pressure in  $P_{St}$ . The additional hyperbolic power control overrides the pilot pressure signal and holds the preset power constant.

Optional:

Pressure control (LR2DN), remote control (LR2GN)

Power characteristic, remote control (LR3N, LR3DN, LR3GN)

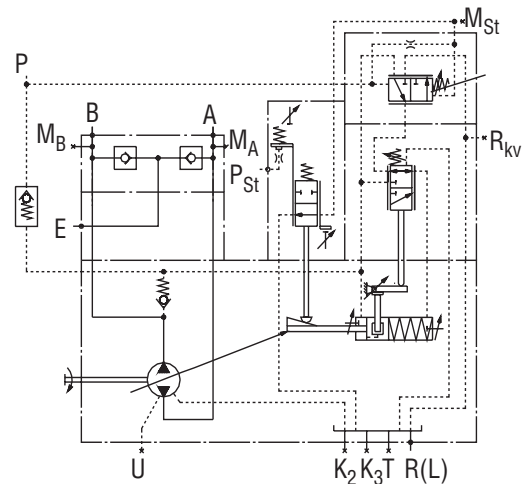
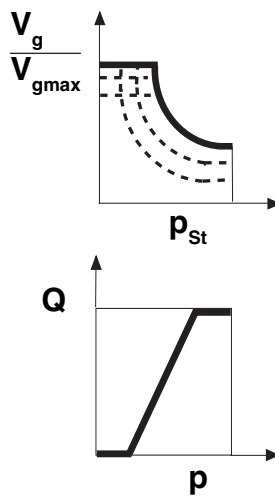

see RE 92064

### Pressure control DR

Single sided operation

Maintains a constant pressure in a hydraulic system

Setting range 20 – 350 bar

Optional:

Remote control (DRG)

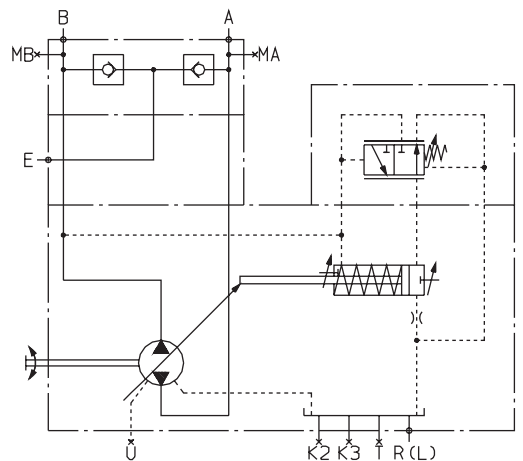
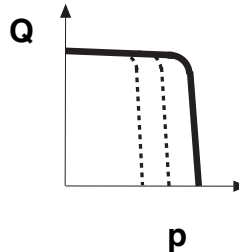

see RE 92060

### Pressure control for parallel operation DP

Single sided operation

Suitable for pressure control of multiple axial piston pumps A4VSG in parallel operation.

Optional:

Displacement control (DPF)

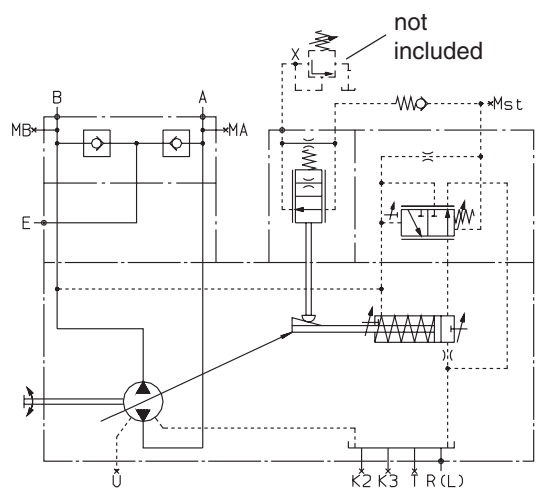
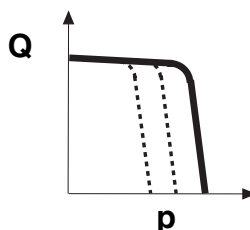

## Through drive

Axial pistons units A4VSG can be supplied with through drive, as indicated in the ordering code on page 3.

It is recommended that no more than three individual pumps are coupled in series.

Included in the supply are:

Coupling, fixing screws, seal and an intermediate flange (if required).

### Combination pumps

Two or more independent circuits are available to the user when combination pumps are fitted.

- If the combination pump consists of **2 Brueninghaus units** and if these are to be **supplied assembled**, the single type codes should be quoted, joined by "+".

Ordering example:

A4VSG 125 EO1/22R – PPB10K339F +

A4VSG 71 HM1/10R – PZB10N000N

- 1.1 If a **gear pump or radial piston pump** is to be **factory fitted** as a combination pump, please refer to RE 90139 (in preparation). This data sheet lists the various pump combinations with the type code of the first pump.

2. **Assembled and piped auxiliary pumps (see page 32)**

Depending on the application, various auxiliary pumps and/or piping are available.

Ordering example:

A4VSG 125 EO1/22R – PPB10H029F

A4VSG with piped auxiliary pump for boost circuit.

A4VSG 71EO1/10R – PPB10 H059F

A4VSG with **one** piped auxiliary pump for a common boost and pilot oil circuit, at speeds of  $n > 2800$  rpm.

It is recommended that no more than three individual pumps are coupled in series.

When designing a combination pump using the same sized pumps (e.g. 125 + 125) in combination with control device HD.P, HD.T, HD.U, please consult us.

### Permissible through drive torque



#### Splined shaft

Size	40	71	125	180	250	355	500	750			
Max. perm. through drive torque at shaft pump 1 (pump 1 + pump 2)											
	$T_{total\ max}$	Nm	446	790	1392	2004	2782	3952	5566	8348	
1	Through torque	$T_{D1max}$	Nm	223	395	696	1002	1391	1976	2783	4174
		$T_{D2max}$	Nm	223	395	696	1002	1391	1976	2783	4174
2	Through torque	$T_{D1max}$	Nm	223	395	696	1002	1391	1976	2783	4174
		$T_{D2max}$	Nm	223	395	696	1002	1391	1976	2783	4174

#### Keyed shaft

Size	40	71	125	180	250	355	500	750			
Max. perm. through drive torque at shaft pump 1 (pump 1 + pump 2)											
	$T_{total\ max}$	Nm	380	700	1392	1400	2300	3557	5200	7513	
1	Through torque	$T_{D1max}$	Nm	223	395	696	1002	1391	1976	2783	4174
		$T_{D2max}$	Nm	157	305	696	398	909	1581	2417	3339
2	Through torque	$T_{D1max}$	Nm	157	305	696	398	909	1581	2417	3339
		$T_{D2max}$	Nm	223	395	696	1002	1391	1976	2783	4174

### Permissible bending moment referred to mounting flange of main pump

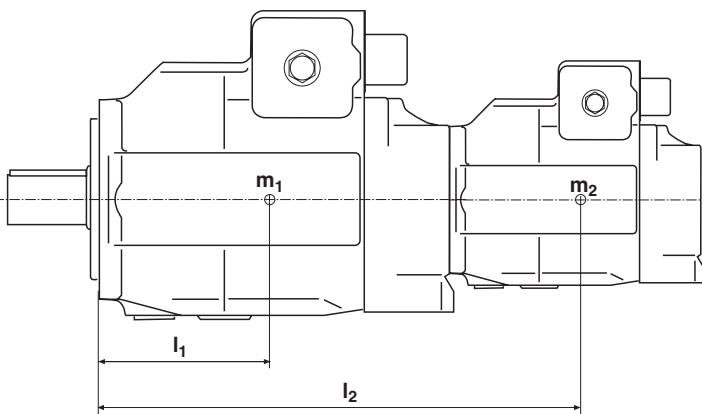

$m_1, m_2$  [kg] Weight of pump  
 $l_1, l_2$  [mm] Offset of c of g

$$T_m = m_1 \cdot l_1 \cdot \frac{1}{102} + m_2 \cdot l_2 \cdot \frac{1}{102} \text{ [Nm]}$$

Size	40	71	125	180	250	355	500	750		
Max. bending moment	$T_{m\ per}$	Nm	1800	2000	4200	4200	9300	9300	15600	19500
Max. bending ment for dynam. accel. of 10 g $\cong$ 98,1 m/sec <sup>2</sup>	$T_{m\ per}$	Nm	180	200	420	420	930	930	1560	1950
Weight	m	kg	47	60	100	114	214	237	350	500
Offset of c of g	$l_1$	mm	120	140	170	180	210	220	230	260

Before finalising your design, please request a certified drawing.  
All rights reserved, subject to revision.

### Unit dimensions for combination pumps

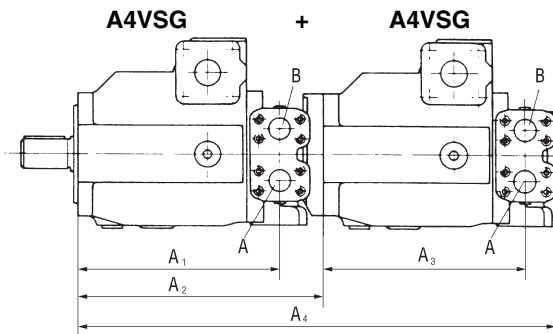

Main p. \ Aux p.	A4VSG 40				A4VSG 71				A4VSG 125				A4VSG 180				A4VSG 250			
	A <sub>1</sub>	A <sub>2</sub>	A <sub>3</sub>	A <sub>4</sub>	A <sub>1</sub>	A <sub>2</sub>	A <sub>3</sub>	A <sub>4</sub>	A <sub>1</sub>	A <sub>2</sub>	A <sub>3</sub>	A <sub>4</sub>	A <sub>1</sub>	A <sub>2</sub>	A <sub>3</sub>	A <sub>4</sub>	A <sub>1</sub>	A <sub>2</sub>	A <sub>3</sub>	A <sub>4</sub>
A4VSG 40	227	288	227	569	259	316	227	597	315	347	227	628	315	371	227	652	386	431	227	712
A4VSG 71	-	-	-	-	259	316	259	623	315	373	259	680	315	397	259	703	386	431	259	737
A4VSG 125	-	-	-	-	-	-	-	-	315	379	315	742	315	403	315	766	386	469	315	832
A4VSG 180	-	-	-	-	-	-	-	-	-	-	-	-	315	403	315	782	386	469	315	848
A4VSG 250	-	-	-	-	-	-	-	-	-	-	-	-	-	-	-	-	386	469	386	912

Main p. \ Aux p.	A4VSG 355				A4VSG 500				A4VSG 750			
	A <sub>1</sub>	A <sub>2</sub>	A <sub>3</sub>	A <sub>4</sub>	A <sub>1</sub>	A <sub>2</sub>	A <sub>3</sub>	A <sub>4</sub>	A <sub>1</sub>	A <sub>2</sub>	A <sub>3</sub>	A <sub>4</sub>
A4VSG 40	393		227		435	505	227	786	467		227	
A4VSG 71	393	460	259	766	435	505	259	811	467		259	
A4VSG 125	393		315		435	505	315	868	467		315	
A4VSG 180	393		315		435	505	315		467		315	
A4VSG 250	393		386		435	541	386	982	467		386	
A4VSG 355	393		393		435		393		467		393	
A4VSG 500	-	-	-	-	435	590	435	1095	467	640	435	1145
A4VSG 750	-	-	-	-	-	-	-	-	467	655	467	

Remaining dimensions on request

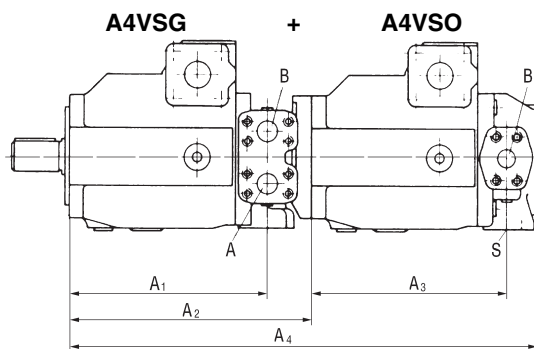

Main p. \ Aux p.	A4VSG 40				A4VSG 71				A4VSG 125				A4VSG 180				A4VSG 250			
	A <sub>1</sub>	A <sub>2</sub>	A <sub>3</sub>	A <sub>4</sub>	A <sub>1</sub>	A <sub>2</sub>	A <sub>3</sub>	A <sub>4</sub>	A <sub>1</sub>	A <sub>2</sub>	A <sub>3</sub>	A <sub>4</sub>	A <sub>1</sub>	A <sub>2</sub>	A <sub>3</sub>	A <sub>4</sub>	A <sub>1</sub>	A <sub>2</sub>	A <sub>3</sub>	A <sub>4</sub>
A4VSO 40	227	288	227	557	259	316	227	585	315	347	227	616	315	371	227	640	386	431	227	700
A4VSO 71	-	-	-	-	259	316	254	615	315	373	254	671	315	397	254	695	386	431	254	729
A4VSO 125	-	-	-	-	-	-	-	-	315	379	310	734	315	403	310	758	386	469	310	824
A4VSO 180	-	-	-	-	-	-	-	-	-	-	-	-	315	403	318	782	386	469	318	848
A4VSO 250	-	-	-	-	-	-	-	-	-	-	-	-	-	-	-	-	386	469	380	908

Main p. \ Aux p.	A4VSG 355				A4VSG 500				A4VSG 750			
	A <sub>1</sub>	A <sub>2</sub>	A <sub>3</sub>	A <sub>4</sub>	A <sub>1</sub>	A <sub>2</sub>	A <sub>3</sub>	A <sub>4</sub>	A <sub>1</sub>	A <sub>2</sub>	A <sub>3</sub>	A <sub>4</sub>
A4VSO 40	393		227		435	505	227	774	467		227	
A4VSO 71	393	460	254	758	435	505	254	803	467		254	
A4VSO 125	393		310		435	505	310	860	467		310	
A4VSO 180	393		318		435	505	318	884	467		318	
A4VSO 250	393		380		435	541	380	980	467		380	
A4VSO 355	393	498	393	966	435		393		467		393	
A4VSO 500	-	-	-	-	435	590	441	1110	467	640	441	1160
A4VSO 750	-	-	-	-	-	-	-	-	467	655	473	1219

Remaining dimensions on request

**Packaging - Processing**  
**Bid on Equipment**  
1-847-683-7720  
[www.bid-on-equipment.com](http://www.bid-on-equipment.com)

Before finalising your design, please request a certified drawing.  
All rights reserved, subject to revision.

**Unit dimensions for combination pumps**

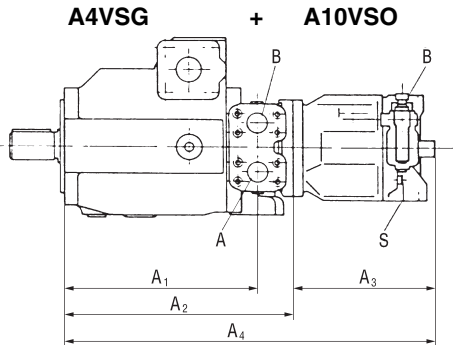

Main p. Aux p.	A4VSG 40				A4VSG 71				A4VSG 125				A4VSG 180				A4VSG 250			
	A <sub>1</sub>	A <sub>2</sub>	A <sub>3</sub>	A <sub>4</sub>	A <sub>1</sub>	A <sub>2</sub>	A <sub>3</sub>	A <sub>4</sub>	A <sub>1</sub>	A <sub>2</sub>	A <sub>3</sub>	A <sub>4</sub>	A <sub>1</sub>	A <sub>2</sub>	A <sub>3</sub>	A <sub>4</sub>	A <sub>1</sub>	A <sub>2</sub>	A <sub>3</sub>	A <sub>4</sub>
A10VSO 18	227	263	195	458	259	291	195	486	315	347	195	542	315	371	195	566	386	431	195	626
A10VSO 28	227	290	206	496	259	316	206	522	315	367	206	573	315	391	206	597	386	431	206	637
A10VSO 45	227	290	224	514	259	311	224	535	315	367	224	591	315	391	224	615	386	431	224	655
A10VSO 71	-	-	-	-	259	321	257	580	315	378	257	635	315	402	257	659	386	449	257	706
A10VSO 100	-	-	-	-	-	-	-	-	315	385	326	711	315	408,5	326	735	386	457	326	783
A10VSO 140	-	-	-	-	-	-	-	-	-	-	-	-	315	-	275	-	386	469	337	806

Main p. Aux p.	A4VSG 355				A4VSG 500				A4VSG 750			
	A <sub>1</sub>	A <sub>2</sub>	A <sub>3</sub>	A <sub>4</sub>	A <sub>1</sub>	A <sub>2</sub>	A <sub>3</sub>	A <sub>4</sub>	A <sub>1</sub>	A <sub>2</sub>	A <sub>3</sub>	A <sub>4</sub>
A10VSO 18	393	460	195	655	435	505	195	700	467	-	195	-
A10VSO 28	393	-	206	-	435	-	206	-	467	-	206	-
A10VSO 45	393	-	224	-	435	505	224	729	467	-	224	-
A10VSO 71	393	478	257	735	435	505	257	762	467	-	257	-
A10VSO 100	393	-	326	-	435	531	326	857	467	-	326	-
A10VSO 140	393	498	337	835	435	530	337	867	467	-	337	-

Remaining dimensions on request

**Dimensions – Through drives**

ISO 125, 4-hole; for building on an A4VSO/H/G 40 (splined shaft)  
Ordering code K31

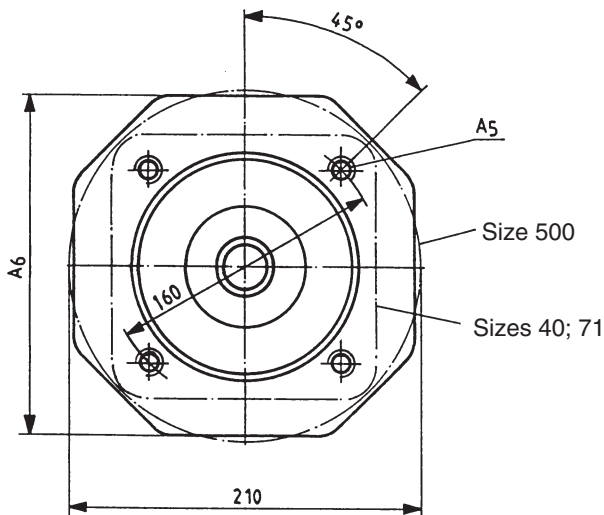

Size Main pump	A <sub>2</sub>	A <sub>3</sub>	A <sub>4</sub>	A <sub>5</sub>	A <sub>6</sub>
40	288	-	58	M12; 24 deep	-
71	316	-	55	M12; 24 deep	-
125	347	8	37	M12; 18 deep	150
180	371	-	37	M12; 18 deep	-
250	431	3	48	M12; 18 deep	200
500	505	12	60	M12; 18 deep	-

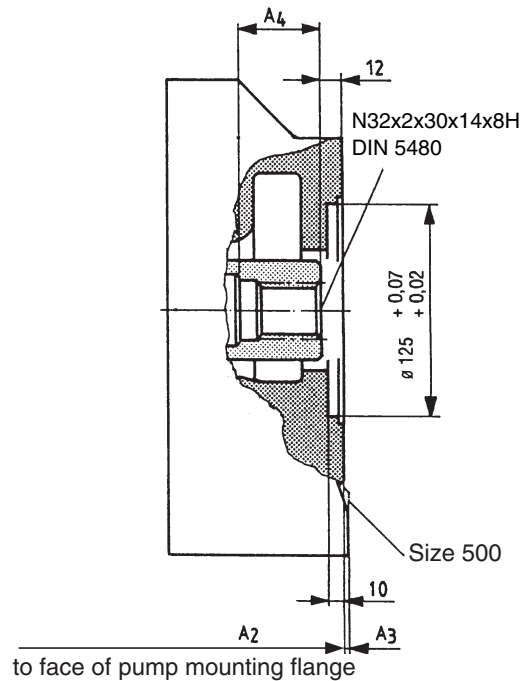

Before finalising your design, please request a certified drawing.  
All rights reserved, subject to revision.

**ISO 140, 4-hole;** for building on an A4VSO/H/G 71 (splined shaft)  
Ordering code **K33**

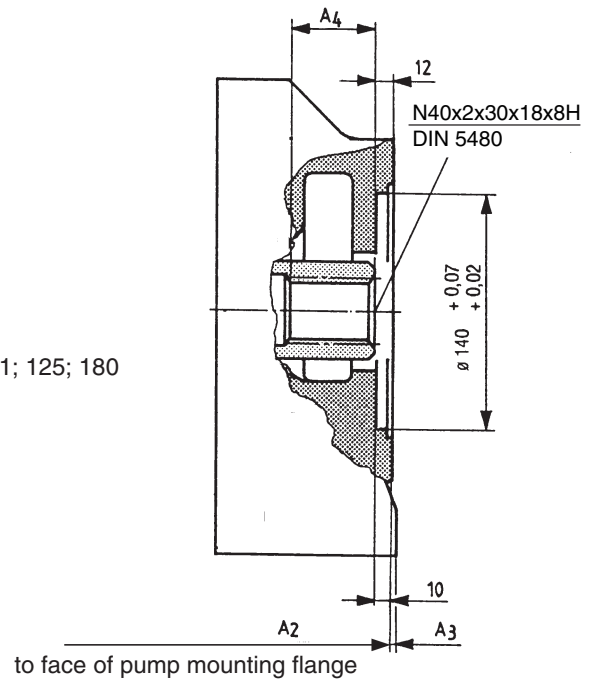
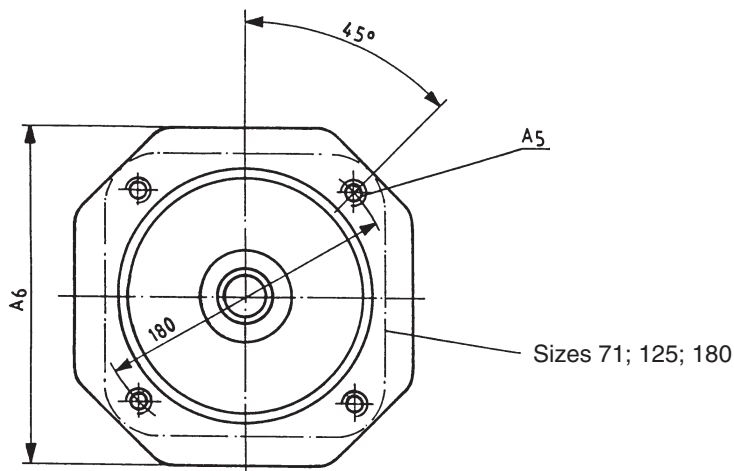

Size Main pump	A <sub>2</sub>	A <sub>3</sub>	A <sub>4</sub>	A <sub>5</sub>	A <sub>6</sub>
71	316	-	50	M12; 24 deep	-
125	373	-	50	M12; 25 deep	-
180	397	-	45	M12; 18 deep	170
250	431	3	48	M12; 18 deep	200
355	460	-	48	M12; 18 deep	220
500	505	12	60	M12; 18 deep	240

**ISO 160, 4-hole;** for building on an A4VSO/H/G 125 or 180 (splined shaft)  
Ordering code **K34**

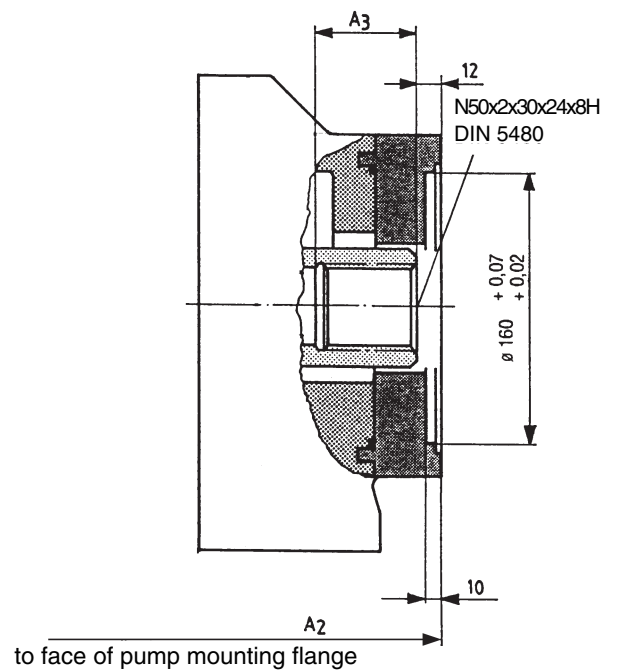
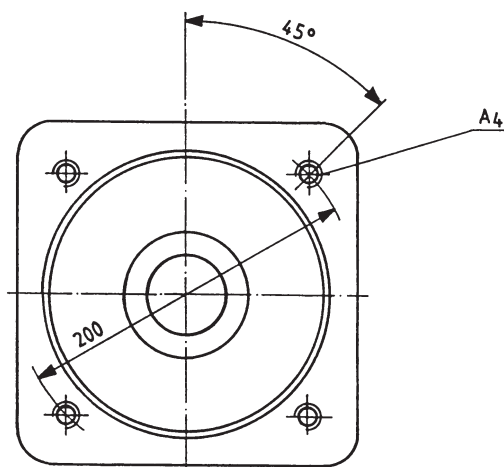

Size Main pump	A <sub>2</sub>	A <sub>3</sub>	A <sub>4</sub>
125	379	58	M16; 31 deep
180	403	53	M16; 32 deep
250	469	60	M16; 32 deep
500	505	60	M16; 24 deep

Before finalising your design, please request a certified drawing.  
All rights reserved, subject to revision.

**ISO 224, 4-hole;** for building on an A4VSO/H/G 250 (splined shaft)  
Ordering code **K35**

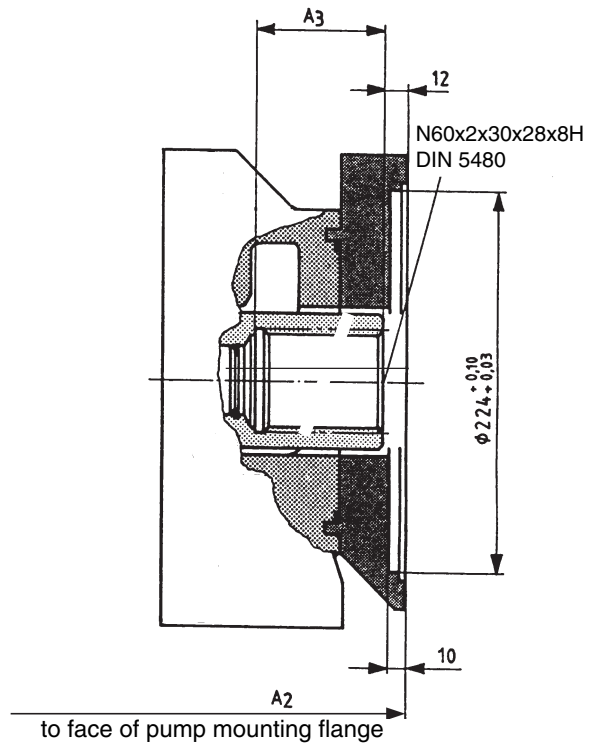
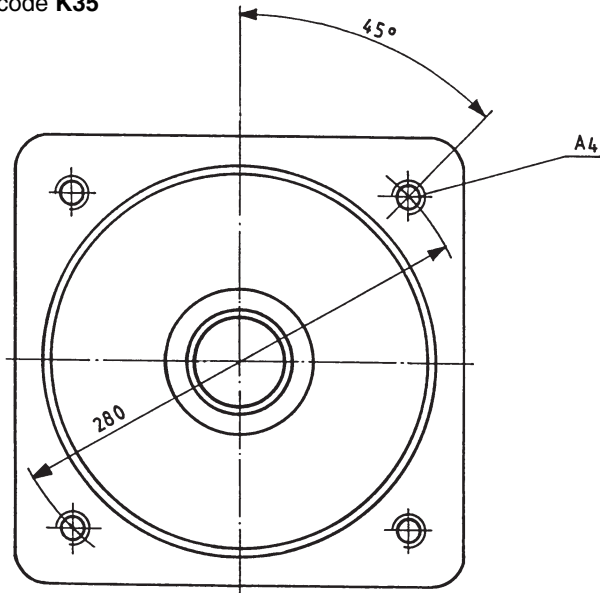

Size	$A_2$	$A_3$	$A_4$
Main pump			
250	469	75	M20; 37 deep
500	541	74	M20; 36 deep

**ISO 224, 4-hole;** for building on an A4VSO/H/G 355 (splined shaft)  
Ordering code **K77**  
Main pump Size 355

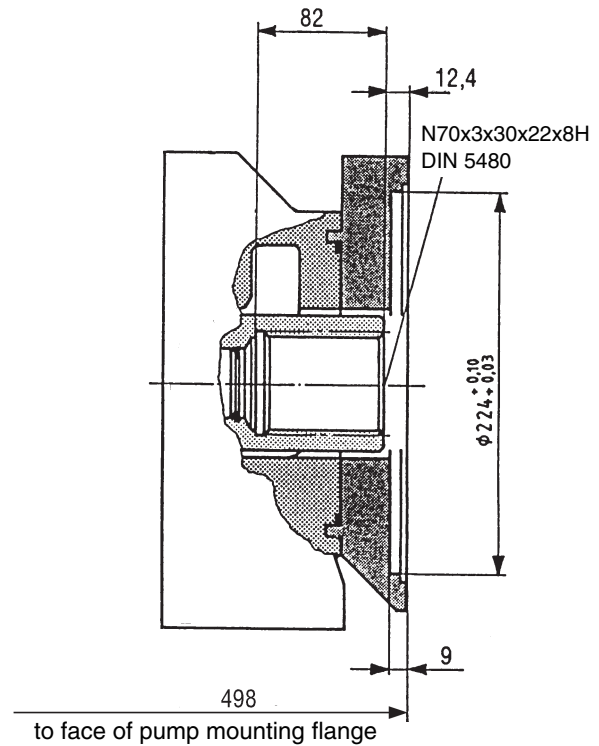
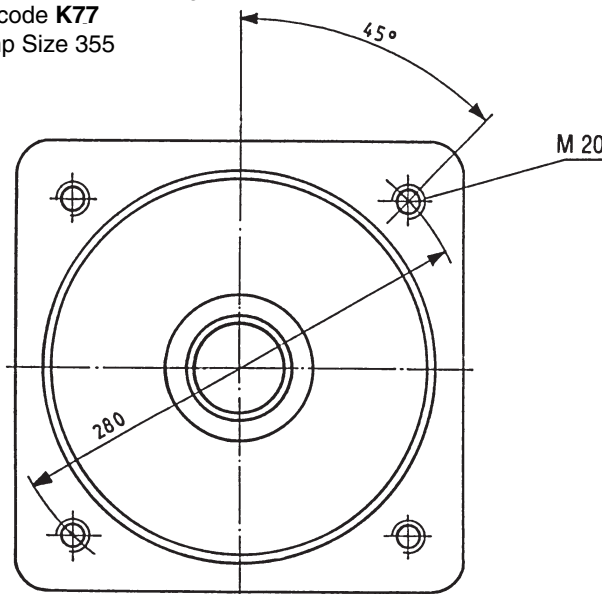

Before finalising your design, please request a certified drawing.  
All rights reserved, subject to revision.

**ISO 315, 8-hole;** for building on an A4VSO/H/G 500 (splined shaft)  
Ordering code **K43**

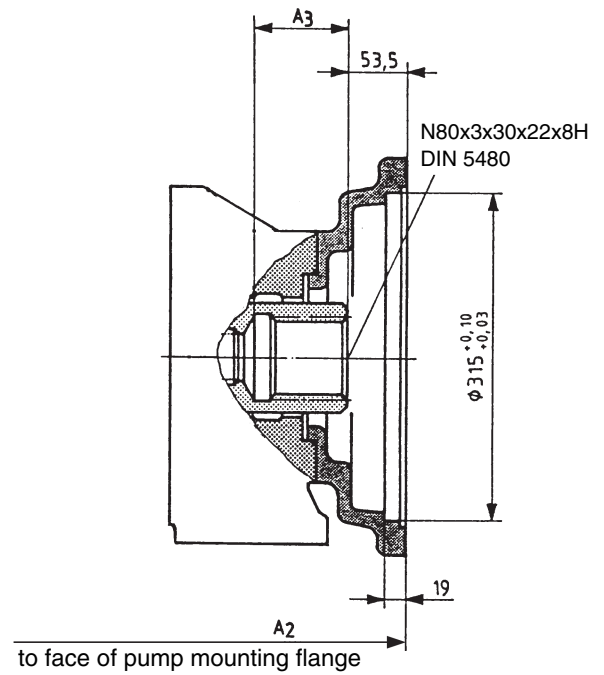
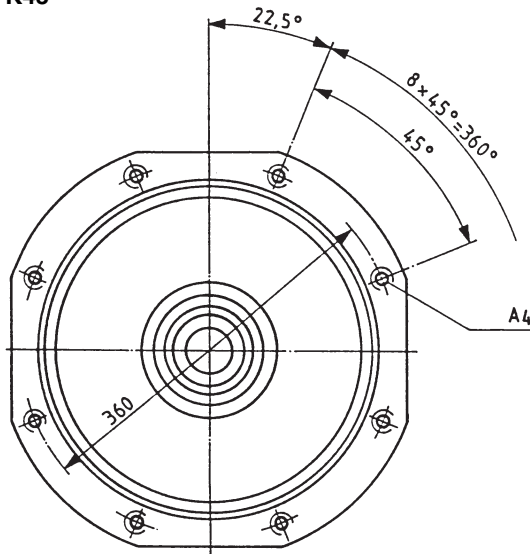

Size	A <sub>2</sub>	A <sub>3</sub>	A <sub>4</sub>
Main pump			
500	590	91	M20;26 deep
750	640	91	M20; 26 deep

**ISO 80, 2-hole;** for building on an A10VSO 18 (keyed shaft) - see RE 92712  
Ordering code **K51**

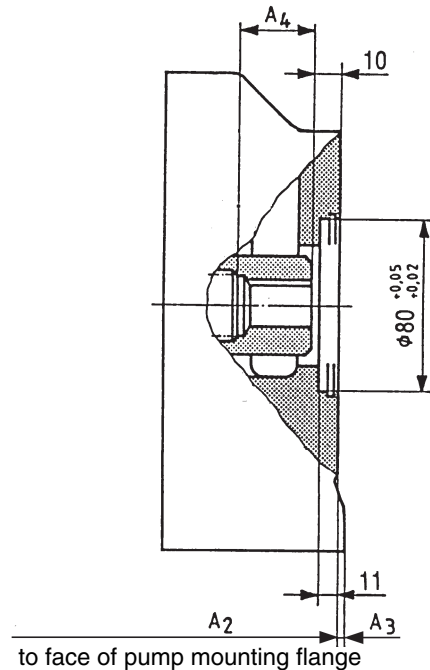
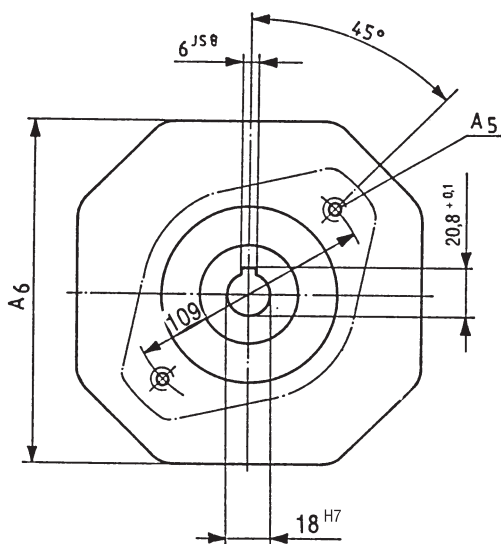

Size	A <sub>2</sub>	A <sub>3</sub>	A <sub>4</sub>	A <sub>5</sub>
Main pump				
40	263	-	27,8	M10
71	291	-	37,5	M10
125	347	11,5	38,2	M10
180	371	-	38,2	M10; 12 deep
250	431	3	33	M10; 12 deep
355	460	-	37,6	M10
500	505	15	42,5	M10

Before finalising your design, please request a certified drawing.  
All rights reserved, subject to revision.

**ISO 100, 2-hole;** for building on an A10VSO 28 (keyed shaft) - see RE 92711  
Ordering code **K25**

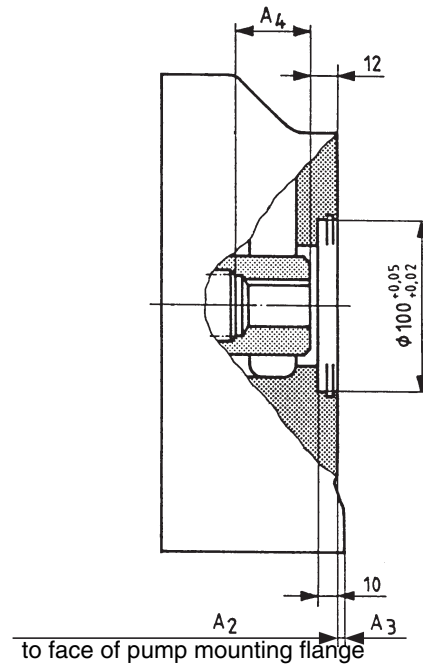
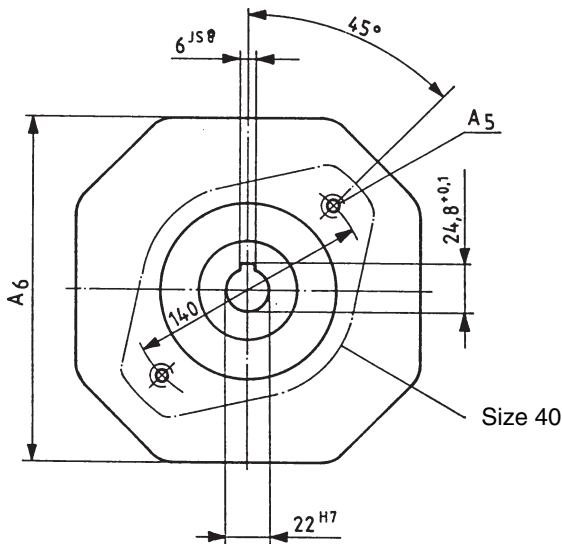

Size Main pump	A <sub>2</sub>	A <sub>3</sub>	A <sub>4</sub>	A <sub>5</sub>	A <sub>6</sub>
40	290	-	55	M12; 26 deep	-
71	316	2	35	M12; 18 deep	140
125	367	-	37	M12; 15 deep	150
180	391	-	37	M12; 15 deep	150
250	431	3	48	M12; 18 deep	200

**ISO 100, 2-hole;** for building on an A10VSO 45 (keyed shaft) - see RE 92711  
Ordering code **K26**

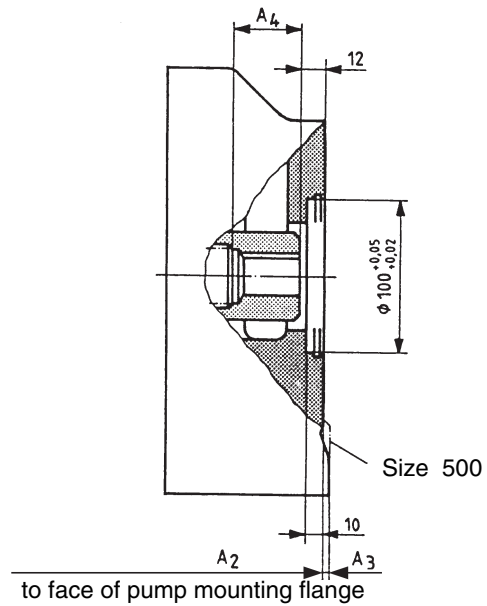
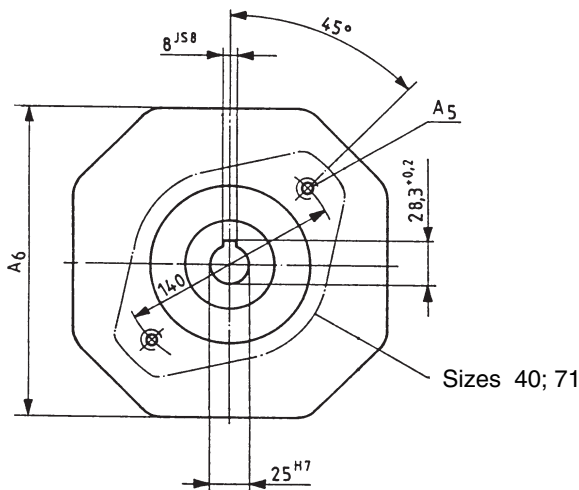

Size Main pump	A <sub>2</sub>	A <sub>3</sub>	A <sub>4</sub>	A <sub>5</sub>	A <sub>6</sub>
40	290	-	61	M12; 26 deep	-
71	311	-	48	M12; 38 deep	-
125	367	-	52	M12; 35 deep	150
180	391	-	52	M12; 20 deep	150
250	431	3	48	M12; 18 deep	200
500	505	12	60	M12; 18 deep	240

Before finalising your design, please request a certified drawing.  
All rights reserved, subject to revision.

**ISO 125, 2-hole;** for building on an A10VSO 71 (keyed shaft) - see RE 92711  
Ordering code **K27**

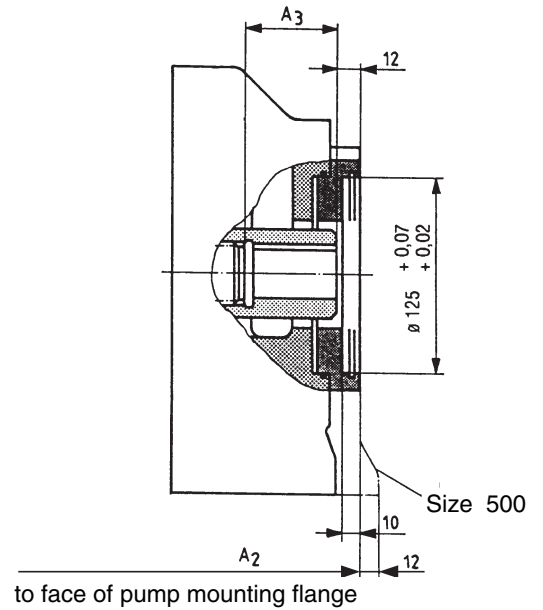
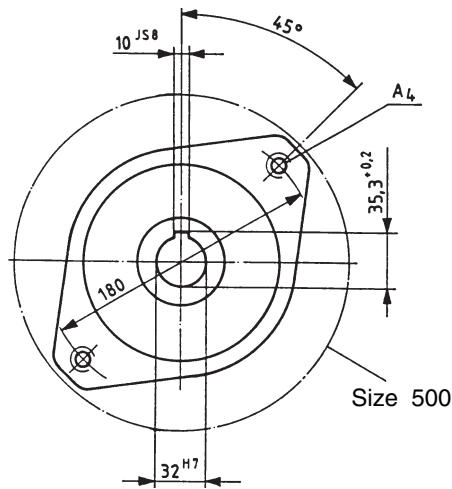

Size Main pump	A <sub>2</sub>	A <sub>3</sub>	A <sub>4</sub>
71	321	62	M16; 29 deep
125	378	63	M16; 24 deep
180	402	58	M16; 24 deep
250	449	62	M16; 24 deep
355	478	62	M16; 24 deep
500	505	60	M16; 24 deep

**ISO 125, 2-hole;** for building on an A10VSO 100 (keyed shaft) - see RE 92711  
Ordering code **K37**

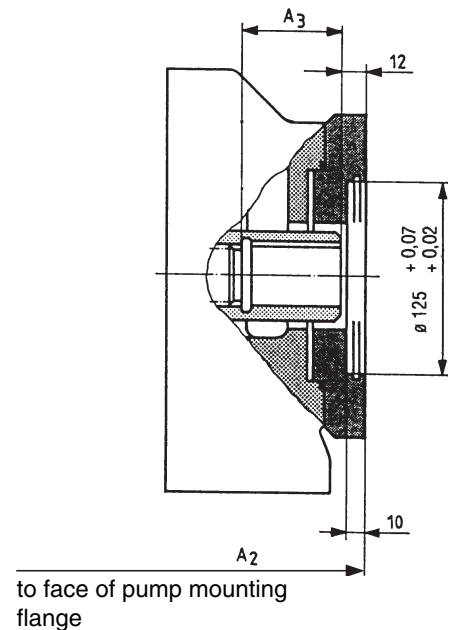
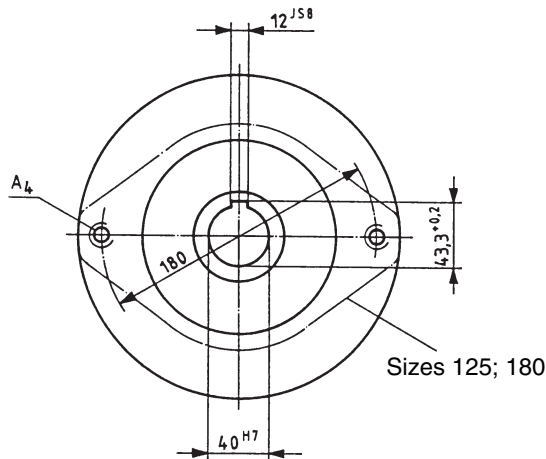

Size Main pump	A <sub>2</sub>	A <sub>3</sub>	A <sub>4</sub>
125	384	70	M16; 24 deep
180	408,5	65	M16; 24 deep
250	457	68	M16; 26 deep
500	531	86	M16; 26 deep

Before finalising your design, please request a certified drawing.  
All rights reserved, subject to revision.

**ISO 180, 4-hole;** for building on an A10VSO 140 (keyed shaft) - see RE 92711  
Ordering code **K59**

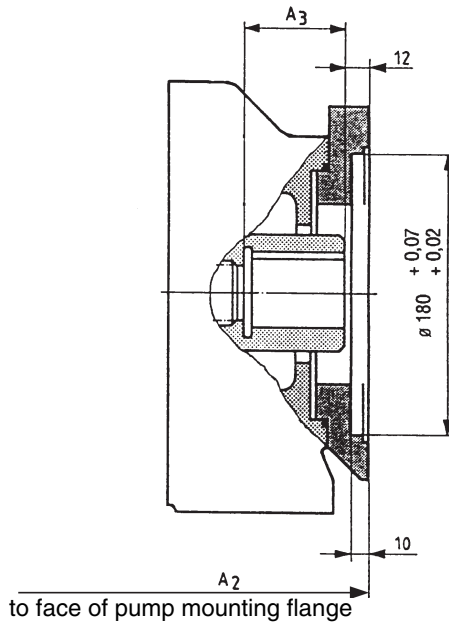
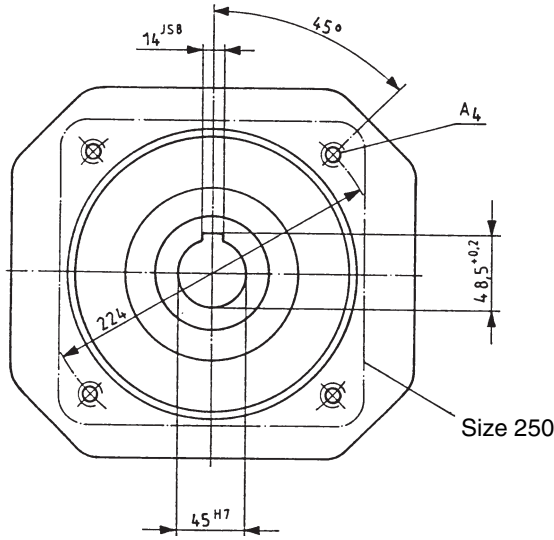

Size Main pump	A <sub>2</sub>	A <sub>3</sub>	A <sub>4</sub>
250	469	79	M16; 32 deep
355	498	79	M16; 32 deep
500	530	85	M16; 25 deep

**Packaging - Processing**  
**Bid on Equipment**  
1-847-683-7720  
[www.bid-on-equipment.com](http://www.bid-on-equipment.com)

**With through drive shaft, without hub or intermediate flange, with cover closed**

Ordering code **K99**

Unit dimensions available on request

**Flange SAE 82-2 (SAE A, 2-hole);** for building on an external gear pump G2 (see RE 10030) or internal gear pump 1 PF2GC2/3-1X/XXXXR07MU2 (see RE 10215) – Ordering code **K01**

**Flange SAE 82-2 (SAE A, 2-hole);** for building on an A10VSO 18 splined shaft "S" (see RE 92712)  
Ordering code **K52**

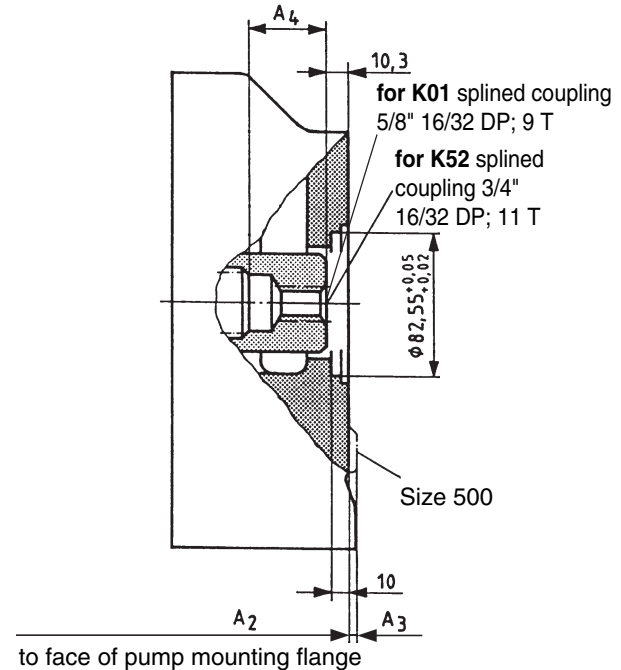
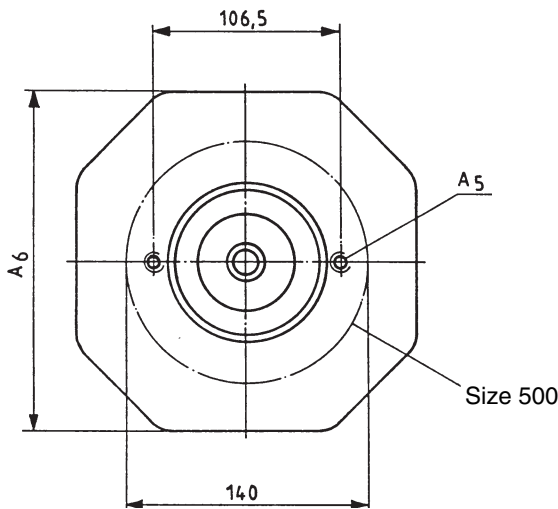

Size Main pump	A <sub>2</sub>	A <sub>3</sub>	A <sub>4</sub>	A <sub>5</sub>	A <sub>6</sub>
40	263	–	40	M10; 15 deep	130
71	291	2	37	M10; 15 deep	140
125	347	8	39	M10; 20 deep	150
180	371	–	28	M10; 15 deep	–
250	431	3	50	M10; 15 deep	200
355	460	–	50	M10; 15 deep	220
500	505	12	62	M10; 15 deep	–

Note that when fitting a G2 or GC type pump, bi-directional rotation is not possible.  
Please also note fluid type (see RE 10030 or 10215)

Before finalising your design, please request a certified drawing.  
All rights reserved, subject to revision.

**Flange SAE 101-2 (SAE B, 2-hole);** for building on an external gear pump G3 (see RE 10039) or an A10VO 28-splined shaft "S" (see RE 92701),  
Ordering code **K02**

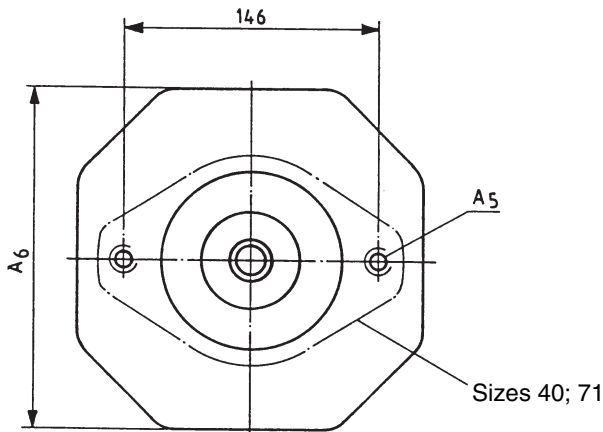

Size Main pump	A <sub>2</sub>	A <sub>3</sub>	A <sub>4</sub>	A <sub>5</sub>	A <sub>6</sub>
40	290	-	66	M12; 26 deep	-
71	322	-	53	M12; 30 deep	-
125	347	8	39	M12; 15 deep	150
180	371	-	39	M12; 15 deep	160
250	431	10	51	M12; 18 deep	200
355	460	-	51	M12; 18 deep	220
500	505	-	63	M12; 18 deep	240
750	555	-	63	M12; 18 deep	258

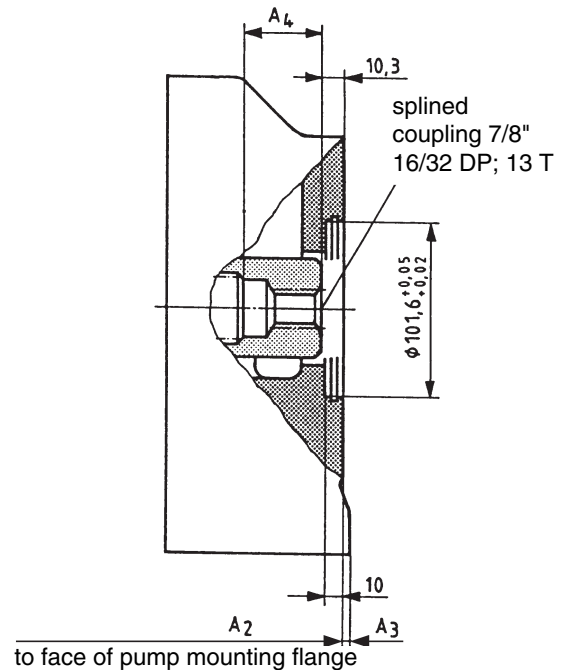

Note that when fitting a G3 type pump, bi-directional rotation is **not** possible.  
Please also **note fluid type** (see RE 10039).

**Flange SAE 101-2 (SAE B, 2-hole);** for building on an internal gear pump 1PF2GC4-1X/0XXXR07MU2, (see RE 10215) or an A10VO 45-splined shaft "S" (see RE 92701),  
Ordering code **K04**

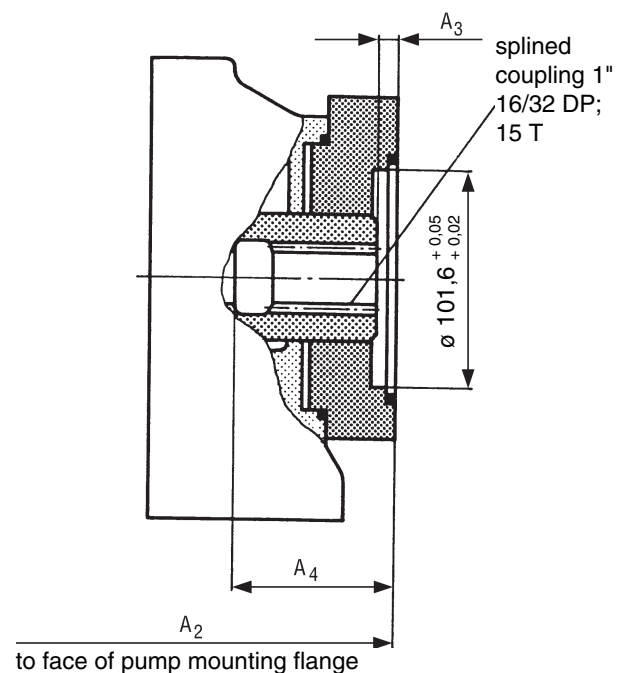
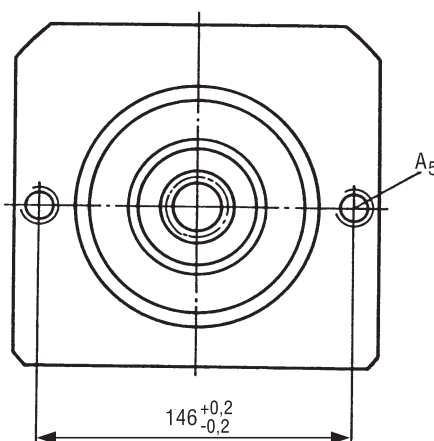

Note that when fitting a GC type pump, bi-directional rotation is **not** possible.  
Please also **note fluid type** (see RE 10215).

Size Main pump	A <sub>2</sub>	A <sub>3</sub>	A <sub>4</sub>	A <sub>5</sub>
125	347	10	49	M12; 15 deep
355	460	9	60	M12; 18 deep

**Packaging - Processing**  
**Bid on Equipment**  
1-847-683-7720  
www.bid-on-equipment.com

Before finalising your design, please request a certified drawing.  
All rights reserved, subject to revision.

**Flange SAE 101-2 (SAE B, 2-hole);** for building on an internal gear pump 1PF2GC5-1X/0XXXXR07MU2,  
(see RE 10215),  
Ordering code **K06**

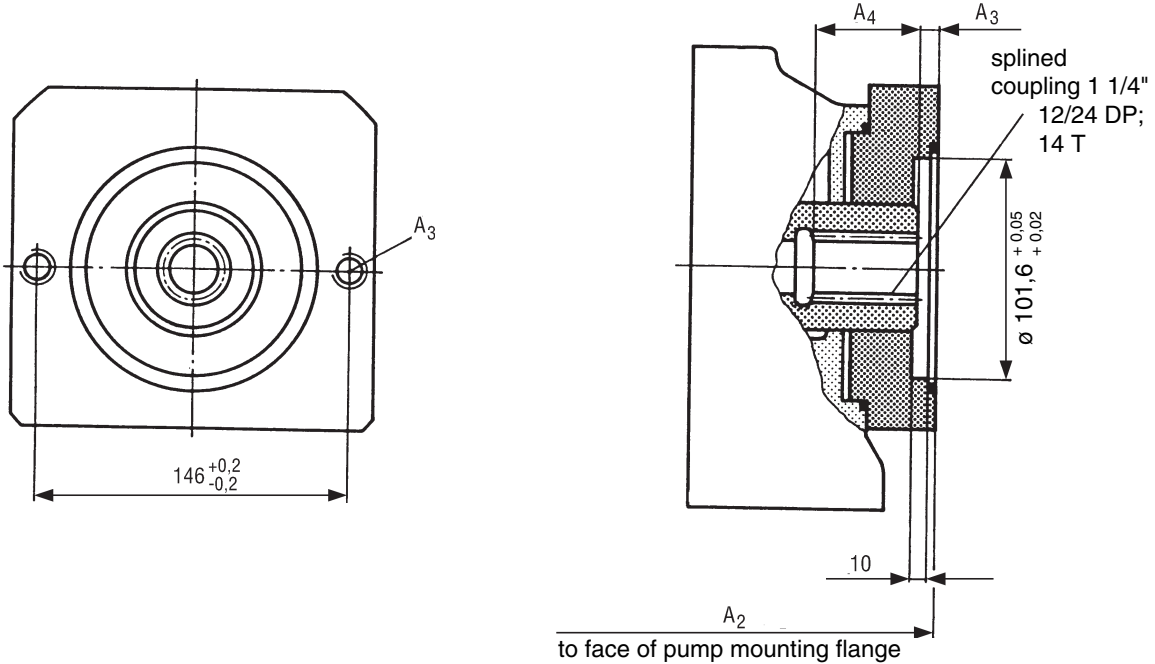

Size				
Main pump	A <sub>2</sub>	A <sub>3</sub>	A <sub>4</sub>	A <sub>5</sub>
125	378	9	13,5	M12; 18 deep

Note that when fitting a GC type pump, bi-directional rotation is **not** possible.  
Please also **note fluid type** (see RE 10215).

**Flange SAE 127-2 (SAE C2-hole);** for building on an internal gear pump 1PF2GC6-1X/XXXXR07MU2,  
(see RE 10215), or an A10VO 100 splined shaft "S" (see RE 92701),  
Ordering code **K24**

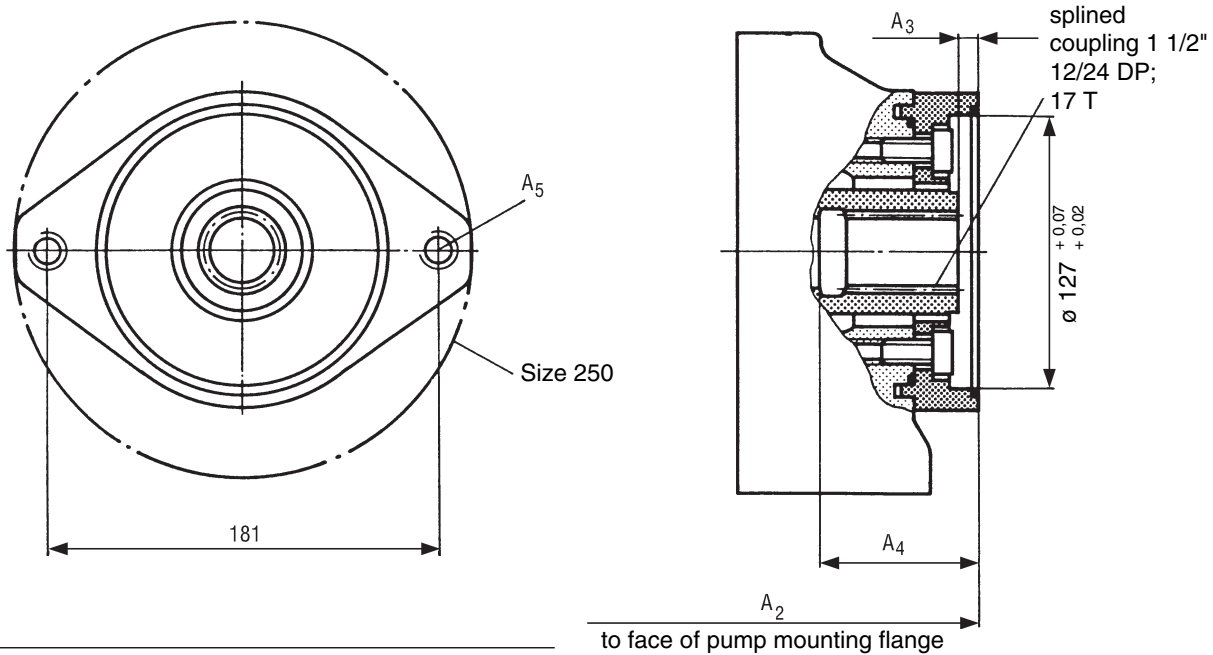

Size				
Main pump	A <sub>2</sub>	A <sub>3</sub>	A <sub>4</sub>	A <sub>5</sub>
125	377	9	74	M16; 24 deep
180	401	10	72	M16; 24 deep
250	451	10,5	76	M16; 20 deep

Note that when fitting a GC type pump, bi-directional rotation is **not** possible.  
Please also **note fluid type** (see RE 10215).

Before finalising your design, please request a certified drawing.  
All rights reserved, subject to revision.

**63 mm dia., 4-hole;** for building on a radial piston pump R4 (see RE 11263), Ordering code **K57**

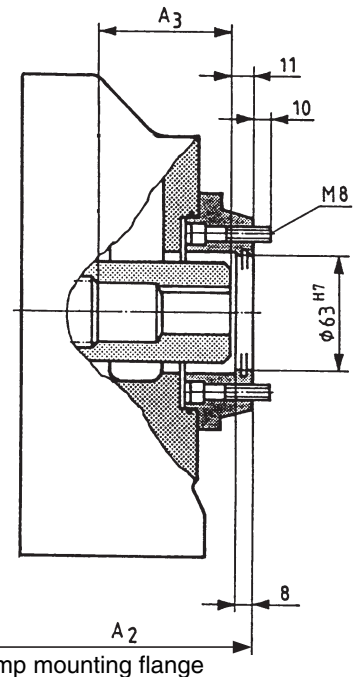
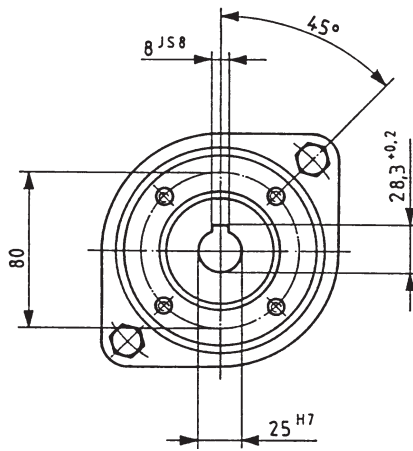

When **fitting an R4 pump** please note **direction of rotation** and **fluid type** (see RE 11263).

\* with A4VSO 40 and 71 LR.D, LR.S, LR.G it is only possible to fit an R4-3 piston pump.

**Packaging - Processing**  
**Bid on Equipment**  
1-847-683-7720  
www.bid-on-equipment.com

Size Main pump	A <sub>2</sub>	A <sub>3</sub>
40*	289	61
71*	319	56
125	375	62
250	459	78

**Flange SAE 101-2 (SAE B, 2-hole);** for building on an external gear pump G4 (see RE 10042)  
Ordering code **K68**

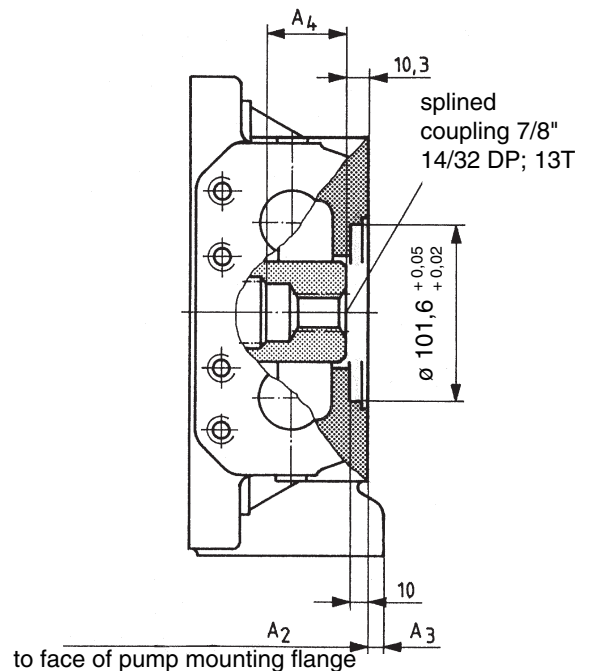
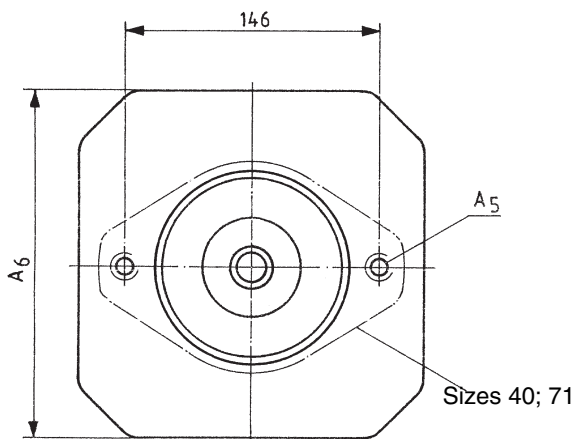

Size Main pump	A <sub>2</sub>	A <sub>3</sub>	A <sub>4</sub>	A <sub>5</sub>	A <sub>6</sub>
40	290	-	66	M12; 26 deep	-
71	322	-	53	M12; 30 deep	-
125	347	8	39	M12; 15 deep	150
180	371	-	39	M12; 15 deep	160
250	431	10	51	M12; 18 deep	200
355	460	-	51	M12; 18 deep	220
500	505	-	63	M12; 18 deep	240
750	555	-	63	M12; 18 deep	258

Note that when **fitting a G4 type pump**, **bi-directional rotation** is **not** possible.  
Please also **note fluid type** (see RE 10042).

Before finalising your design, please request a certified drawing.  
All rights reserved, subject to revision.

**With through drive shaft, without hub or intermediate flange, with cover closed**

Ordering code **K99**

**Size 40 - 355**

(Size 500 see page 31)

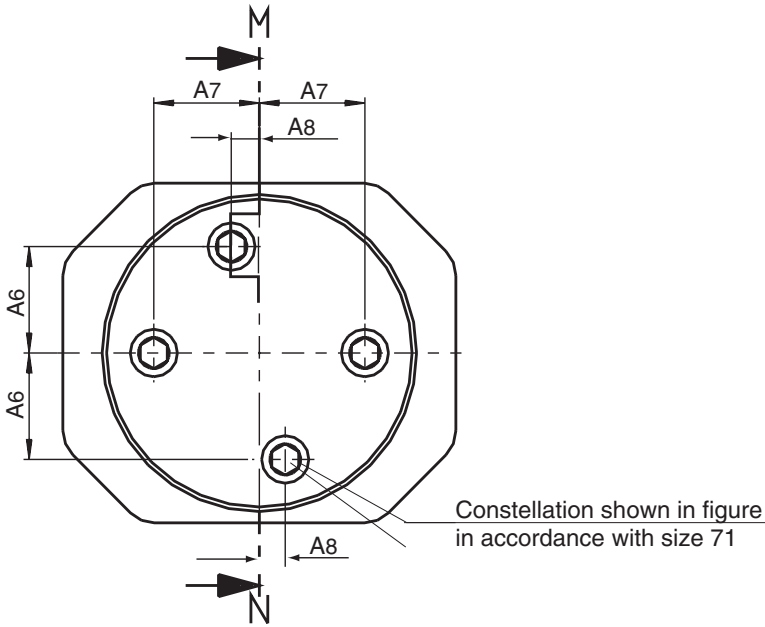

**Section M - N**

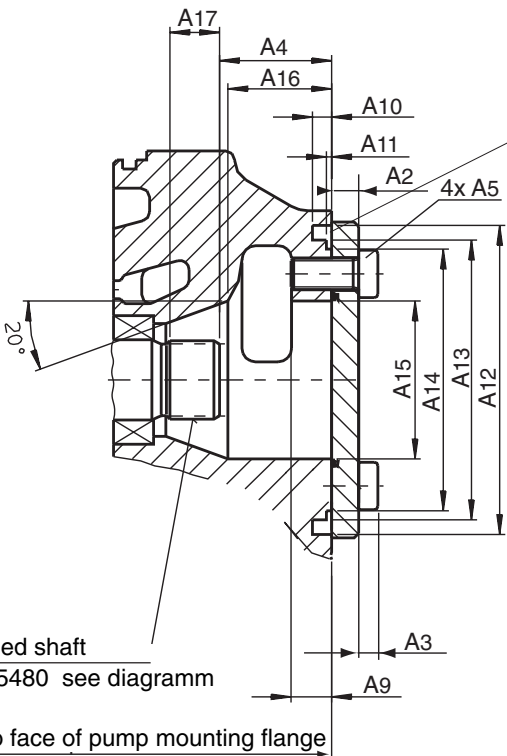

Size Main pump	O-ring (not included in supply)	Splined shaft DIN 5480
40	99x3 78 SH A	W25x1,25x30x18x9g
71	PRP 245 7509	W30x1,25x30x22x9g
125	119x3 78 SH A	W35x1,25x30x26x9g
180	119x3 78 SH A	W35x1,25x30x26x9g
250	162x3 78 SH A	W42x1,25x30x32x9g
355	162x3 78 SH A	W42x1,25x30x32x9g

**Packaging - Processing**  
**Bid on Equipment**  
1-847-683-7720  
[www.bid-on-equipment.com](http://www.bid-on-equipment.com)

Size Main pump	A <sub>1</sub>	A <sub>2</sub>	A <sub>3</sub>	A <sub>4</sub>	A <sub>5</sub>	A <sub>6</sub>	A <sub>7</sub>	A <sub>8</sub>	A <sub>9</sub>	A <sub>10</sub>	A <sub>11</sub>	A <sub>12</sub>	A <sub>13</sub>	A <sub>14</sub>	A <sub>15</sub>	A <sub>16</sub>	A <sub>17</sub>
40	263	10	7,5	51,3±1	M12x25	37±0,2	37±0,2	0	18	9	2,3+0,1	∅118	∅105 <sub>g6</sub>	∅97,6 <sub>-0,4</sub>	∅52	44	14
71	291	10	7,5	48±1	M12x28	42,3	45±0,15	15,4±0,15	18	9	2,7+0,1	∅130	∅116 <sub>g6</sub>	∅106,4 <sub>-0,4</sub>	∅63	39	16
125	347	12	8,5	49,7±1	M14x30	47±0,15	47±0,15	0	18	8,5	2,3+0,1	∅137	∅124 <sub>g6</sub>	∅116 <sub>-0,4</sub>	∅70	46	22
180	371	12	8,5	49,7±1	M14x30	47±0,15	47±0,15	0	18	8,5	2,3+0,1	∅137	∅124 <sub>g6</sub>	∅116 <sub>-0,4</sub>	∅70	46	25
250	431	15	12	61,4±1	M20x40	63±0,15	63±0,15	0	26	9	2,3+0,1	∅180	∅165 <sub>g6</sub>	∅157 <sub>-0,4</sub>	∅88	64	30,5
355	460	15	12	61,4±1	M20x40	63±0,15	63±0,15	0	26	9	2,3+0,1	∅180	∅165 <sub>g6</sub>	∅157 <sub>-0,4</sub>	∅88	64	34

Before finalising your design, please request a certified drawing.  
All rights reserved, subject to revision.

**With through drive shaft, without hub or intermediate flange, with cover closed**  
Ordering code **K99**  
Size **500 - 1000**

drawn without cover

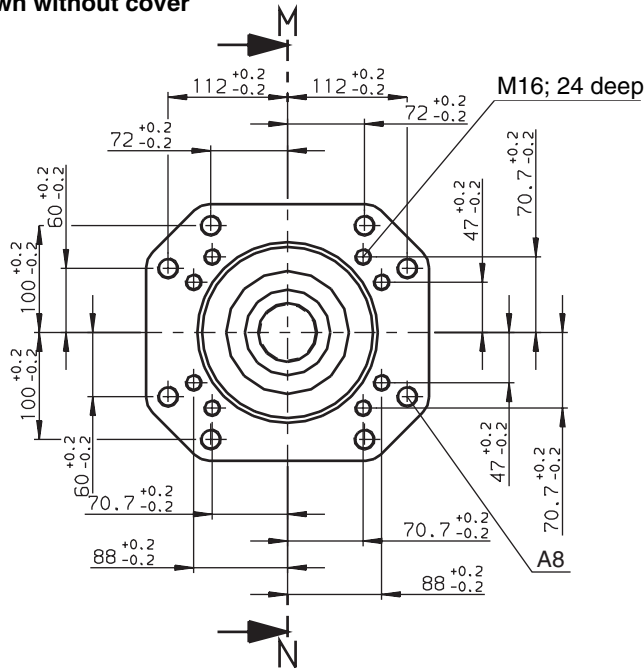

**Section M - N**

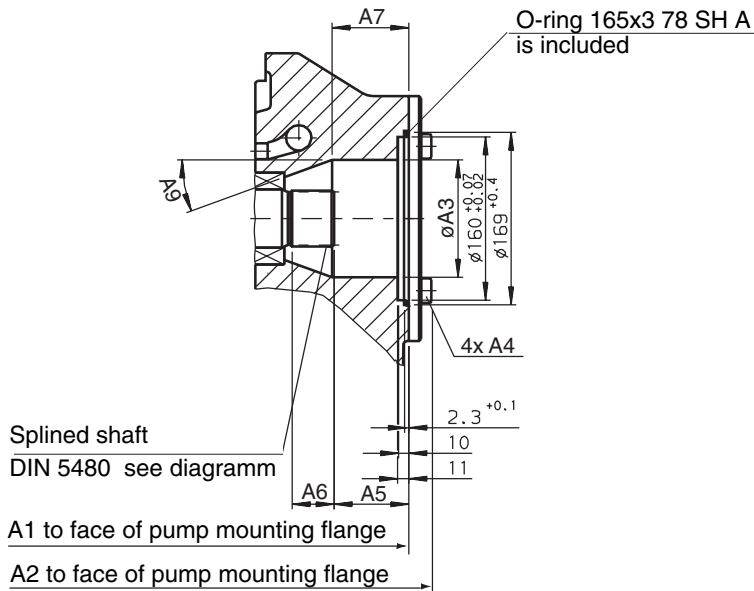

Size	Main pump	A <sub>1</sub>	A <sub>2</sub>	A <sub>3</sub>	A <sub>4</sub>	A <sub>5</sub>	A <sub>6</sub>	A <sub>7</sub>	A <sub>8</sub>	A <sub>9</sub>	Splined shaft DIN 5480
500		505	520	∅115	M16x30	73	41	75	M20;24 deep	20°	W55x1,25x30x42x9g
750		555	577	∅115	M16x24	73	41	75	M20;24 deep	20°	W55x1,25x30x42x9g
1000		628	653	∅142	M16x24	75	50	65	M20;30 deep	15°	W65x1,25x30x50x9g

**40** **H03**  
**Example – A4VSG 71 EO1K/10L–PPB10H029F**  
**125** **22**  
**180**

**Circuit diagram**

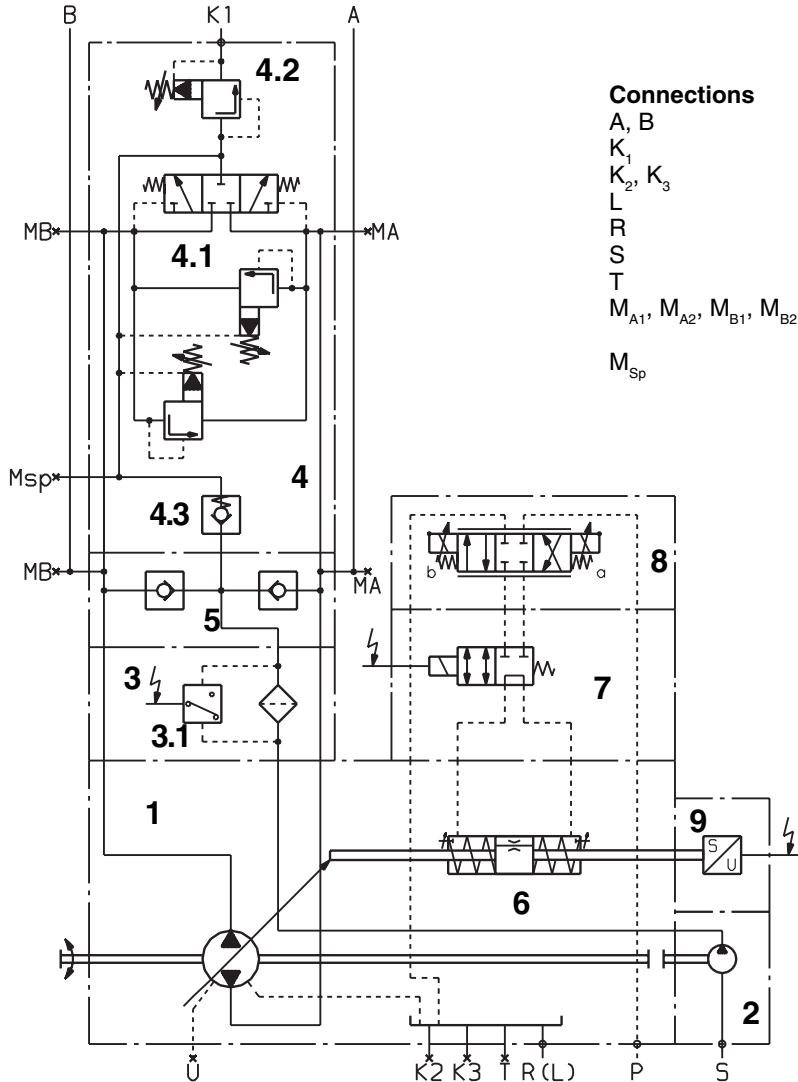

**Connections**

- A, B Pressure ports
- K<sub>1</sub> Flushing port
- K<sub>2</sub>, K<sub>3</sub> Housing flushing ports (plugged)
- L Case drain port
- R Return line or bleed
- S Suction port auxiliary pump
- T Oil drain (plugged)
- M<sub>A1</sub>, M<sub>A2</sub>, M<sub>B1</sub>, M<sub>B2</sub> Gauge ports for operating pressure (plugged)
- M<sub>Sp</sub> Gauge port for flushing pressure (plugged)

Item	Ordering code	
1	Variable pump A4VSG 40-180	<b>A4VSG</b>
2	Boost pump - for options see page 32 (mounted and piped)	<b>H 02</b> or <b>H 03</b>
3	Boost circuit filter	
3.1	Opto-electrical clogging indicator	<b>F</b>
4	Valve block SDVB 16 for A4VSG 40-180	
4.1	Pressure relief valve	<b>9</b>
4.2	Flushing valve	
4.3	Non-return valve	
5	Boost circuit check valves	standard on A4VSG
6	Hydraulic control device	
7	Short circuit valve Z4WE6E68-2X/AG24NZ4	<b>EO 1K</b>
8	4/3-way proportional valve	
9	Inductive positional transducer (feedback device)	

Electronic control not included. To be ordered separately.

Before finalising your design, please request a certified drawing.  
All rights reserved, subject to revision.

### Unit dimensions

A4VSG with auxiliary pump, flushing block, inductive positional transducer and filter

**Packaging - Processing**  
**Bid on Equipment**  
 1-847-683-7720  
[www.bid-on-equipment.com](http://www.bid-on-equipment.com)

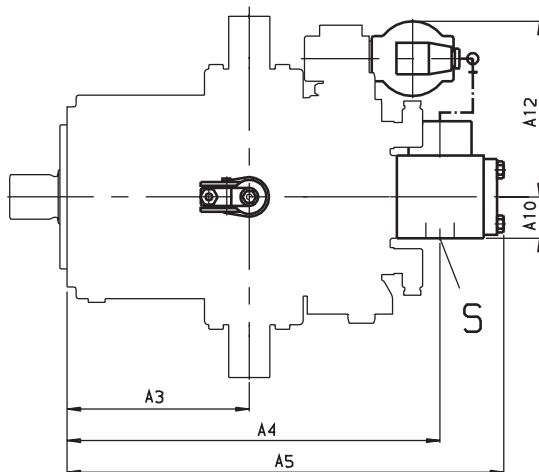
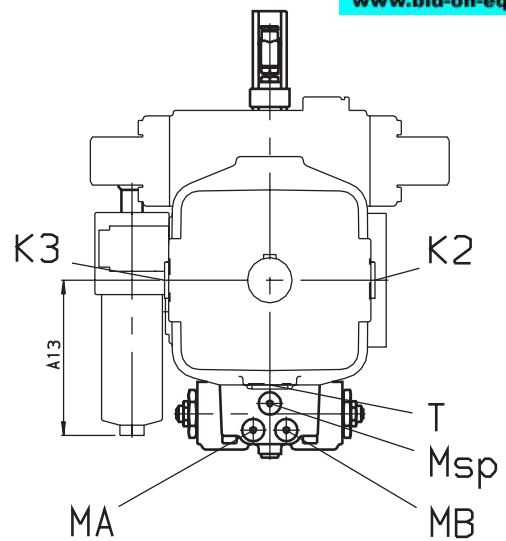
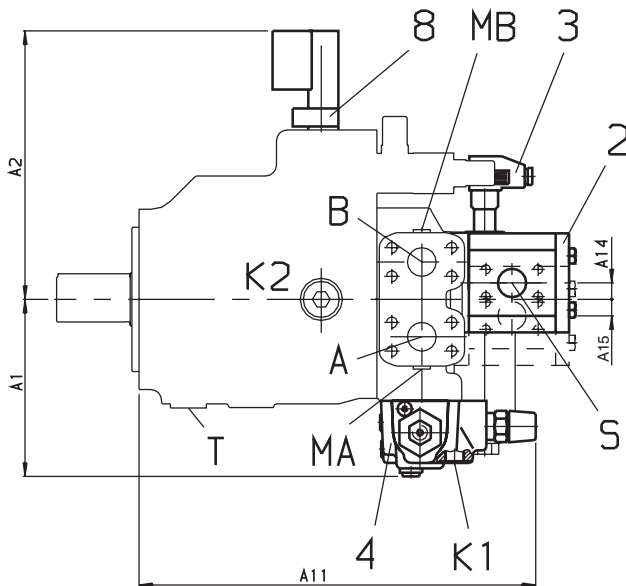

#### Connection S (for options see page 32)

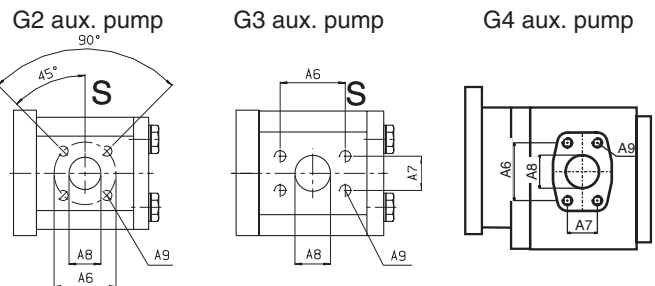

#### Unit dimensions

Size	A <sub>1</sub>	A <sub>2</sub>	A <sub>3</sub>	A <sub>4</sub>	A <sub>5</sub>	A <sub>6</sub>	A <sub>7</sub>	A <sub>8</sub>	A <sub>9</sub>	A <sub>10</sub>	A <sub>11</sub>	A <sub>12</sub>	A <sub>13</sub>	A <sub>14</sub> <sup>*</sup>	A <sub>15</sub> <sup>*</sup>
40	174	246	144	311	361	40	-	20	M6; 13 deep	42	approx. 364	175	115	16,3	16,3
71	177	265	166	337 <sup>1)</sup>	341 <sup>1)</sup>	40	-	20	M6; 13 deep	42	389	180	115	16,3	16,3
71				340 <sup>2)</sup>	345 <sup>2)</sup>	40									
125	196,5	298	203	409	473	52,5	26,2	25,4	M10; 16 deep	46	442	195	172	18,3	18,3
180	196,5	298	203	439,5	511	58,8	30,2	31,75	M10; 16 deep	46	442	228	178	18,3	18,3
250	317	345	248	519,5	590,5	58,8	30,2	31,75	M10; 16 deep	46	448	228	167	18,3	18,3
355	319	345	248	566	641	69,8	35,8	38	M12	90	455	266	218	24,3	24,3
500	353	392	279	622	708	77,8	42,8	50	M12	104	487	260	203	24,3	24,3

<sup>1)</sup> G2: Size 11    <sup>2)</sup> G2: Size 16

<sup>\*</sup> A<sub>14</sub> when fitting aux. pump clockwise direction of rotation

<sup>\*</sup> A<sub>15</sub> when fitting aux. pump anti-clockwise direction of rotation

#### Ports

Size	M <sub>A</sub> , M <sub>B</sub>	K <sub>1</sub>	K <sub>2</sub> , K <sub>3</sub>	S	M <sub>SP</sub>
40	M14x1,5	M22x1,5; 14 deep	M22x1,5	rectangular flange form B	M14x1,5
71	M14x1,5	M22x1,5; 14 deep	M27x2	rectangular flange form B	M14x1,5
125	M14x1,5	M22x1,5; 14 deep	M33x2	SAE 1" (standard pressure series)	M14x1,5
180	M14x1,5	M22x1,5; 14 deep	M33x2	SAE 1 1/4" (standard pressure series)	M14x1,5
250	M14x1,5	M33x2; 18 deep	M42x2	SAE 1 1/4" (standard pressure series)	M22x1,5
355	M14x1,5	M33x2; 18 deep	M42x2	SAE 1 1/2" (standard pressure series)	M22x1,5
500	M14x1,5	M33x2; 18 deep	M48x2	SAE 2" (standard pressure series)	M22x1,5

## Mounted and piped auxiliary pumps H02 - H05

The following auxiliary pumps are supplied mounted and piped:

Size A4VSG		40	71	125	180	250	355	500750	Designation
1 auxiliary pump for <b>boost oil circuit</b> n < 2800 rpm mounted aux. pump	cm <sup>3</sup>	–	G2 16	G3 26	G3 32	G3 38	G4 80	G4 100	○ <b>H02</b>
1 auxiliary pump for <b>boost oil circuit</b> n > 2800 rpm mounted aux. pump	cm <sup>3</sup>	G2 11	G2 11	–	–	–	–	–	<b>H03</b>
1 auxiliary pump for <b>common boost and pilot oil circuit</b> (only with EO1) n < 2800 rpm mounted aux. pump	cm <sup>3</sup>	–	G2 16	G3 26	–	G3 38	–	–	<b>H04</b>
1 auxiliary pump for <b>common boost and pilot oil circuit</b> (only with EO1) n > 2800 rpm mounted aux. pump	cm <sup>3</sup>	G2 11	G2 11	–	–	–	–	–	<b>H05</b>

For unit dimensions and technical data see individual data sheets:

G2 - RE 10030

G3 - RE 10039

G4 - RE 10042

○ = in preparation or on request

**Valve block SDVB 16** (for Sizes 40...180), **SDVB 30** control type 1 (for Sizes 250...500) and **SDVB 50** (for Sizes 750 and 1000) see RE 95533 (in preparation)