

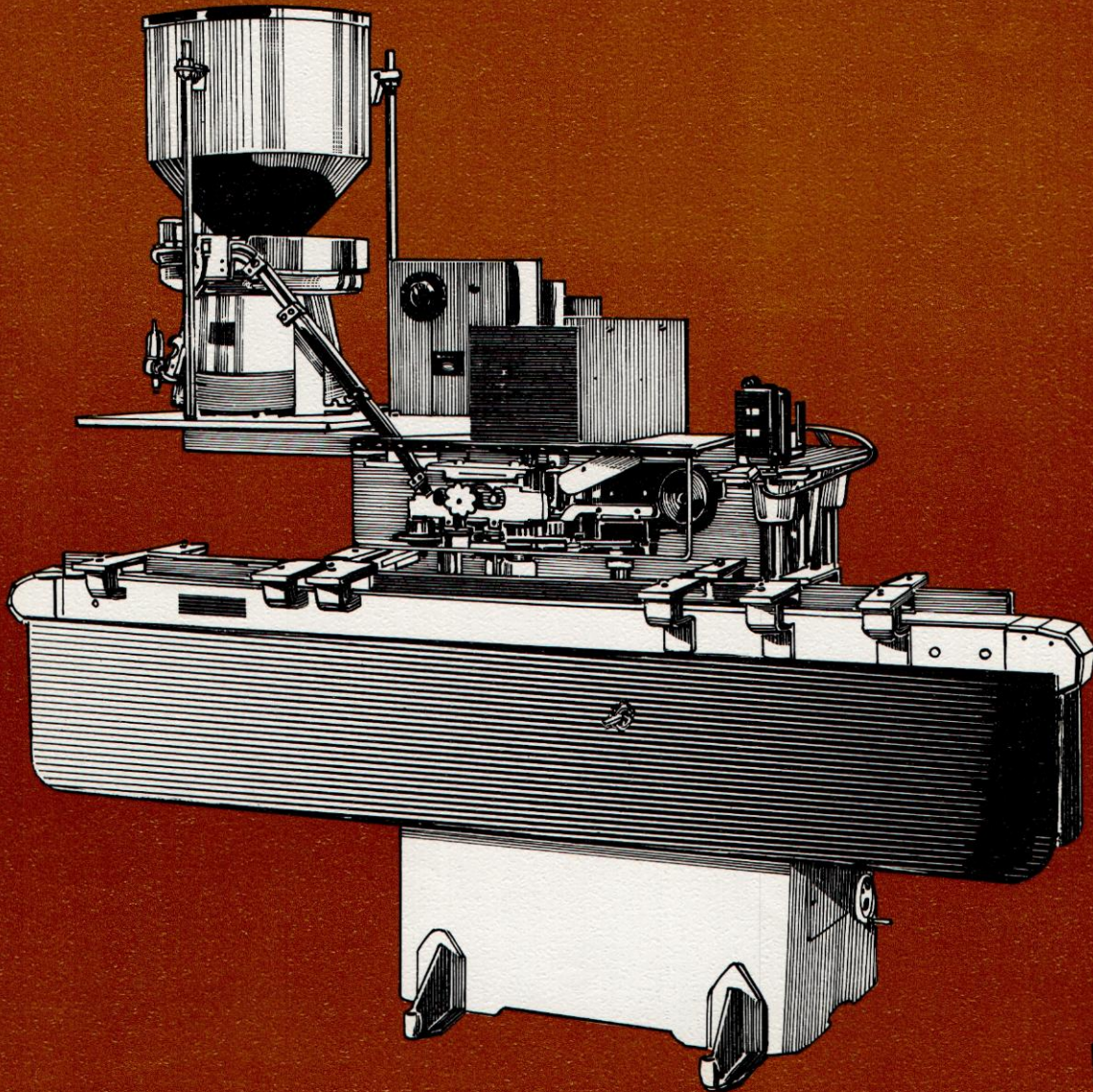

The up-to-120 per minute FULLY AUTOMATIC PLASTIC RESTRICTION PLUG INSERTER MODEL P-22

Industries
Cosmetic
Pharmaceutical
Special Applications



The Versatile, Simple to Use, Easy Changeover Cappers

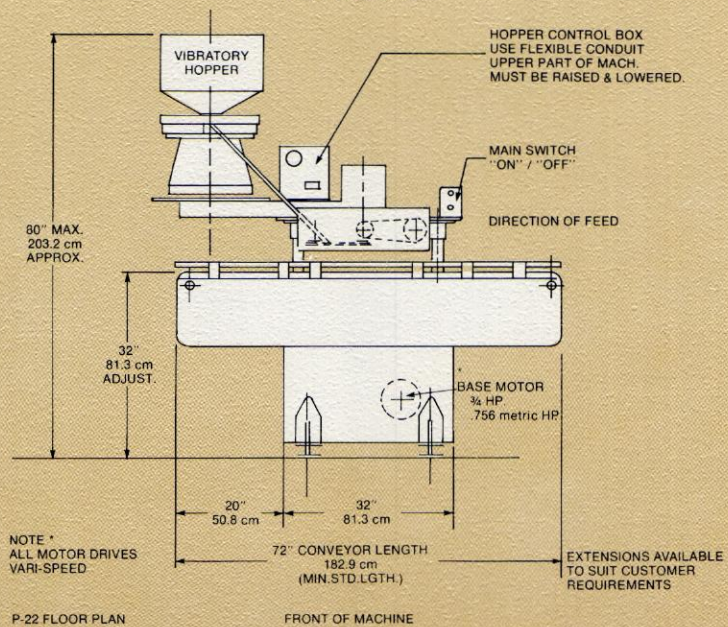
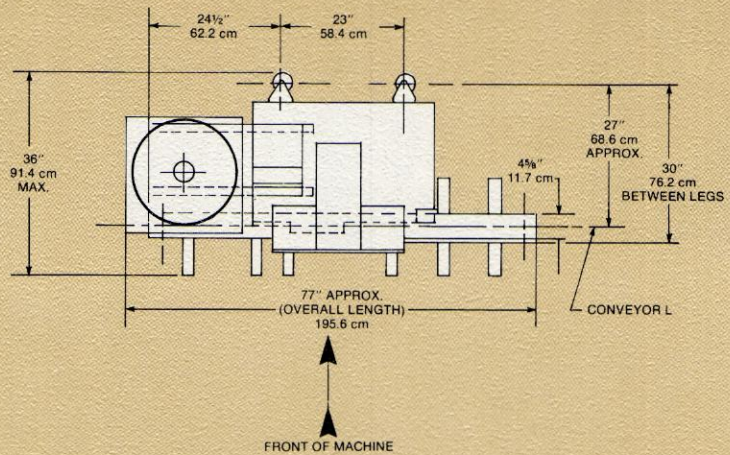

APPROX. WEIGHT 2000 #
907 KG

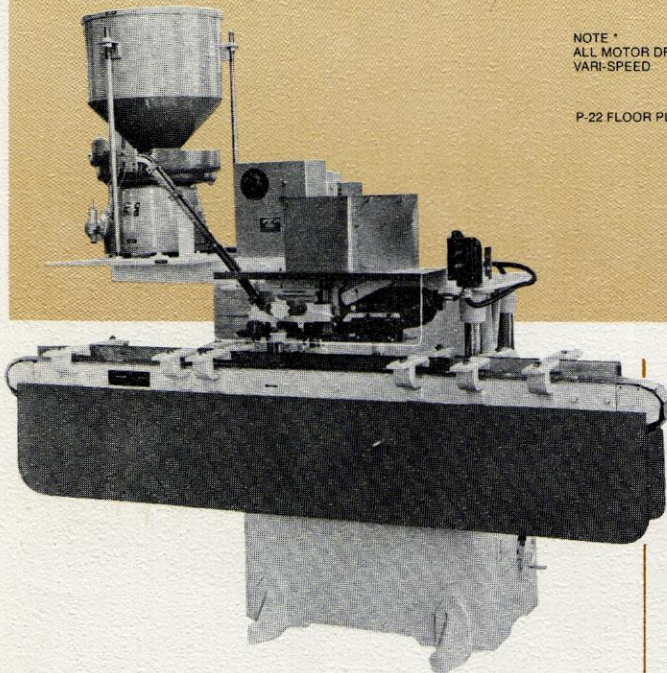

Plug range: 18 to 24mm
Speeds: 60 to 120 plugs per minute
Approximate weight: 2,000 lbs.

Special Variations Quoted Upon Request

General Description —

Equipped with six ft. of powered conveyor, explosion proof motors, vibratory hopper, change parts for one size plug and one size container. This machine can handle a variety of plugs.



BROOKLYN, N.Y. 11231
(212) 875-6020

REPRESENTED BY:

