

RESINA

fully automatic

FITMENT APPLICATOR

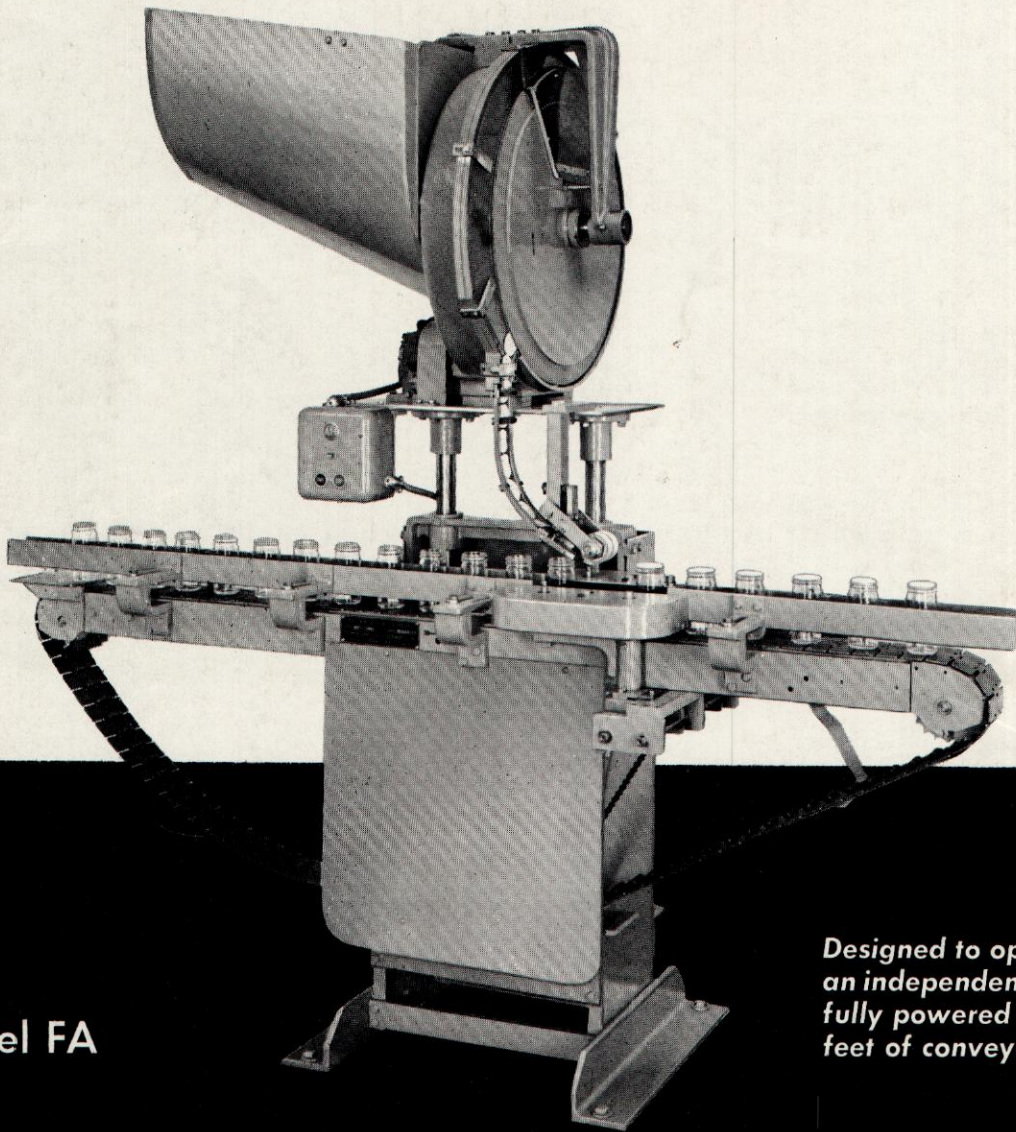

Model FA

Designed to operate as
an independent machine,
fully powered with 6
feet of conveyor.

RESINA

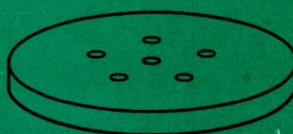

RESINA

OPERATION: The RESINA Fitment Applicator automatically selects plastic fitments (solid or perforated types) with or without lift tabs and orients them into a chute. The passing container picks up a fitment from the chute, which is then snapped on the container. If no container is in position no fitment will be picked up. This eliminates the need for a timing mechanism. Containers move in a straight line, firmly gripped in rubber-faced belts during the fitment application operation.

FLEXIBILITY: The Model FA can handle a wide range of fitments, solid or perforated, and with or without lift tabs as commonly used in the drug and pharmaceutical packaging industry.

QUICK CHANGEOVER: Changing from one size fitment to another is only a matter of 10 to 15 minutes. All that is required is to change a short section of the chute, turn the crank to set the height of the machine, adjust gripper belts and guide rails and a simple hopper dial adjustment and the machine is ready for high speed automatic production.

CAPACITY: From 20 to 120 fitments per minute. Machine available with speeds up to 300 per minute depending upon fitment and container.

MINIMUM MAINTENANCE: Construction is extremely simple and does not require any special skills to keep the machine operating at top efficiency with practically no down-time whatsoever.

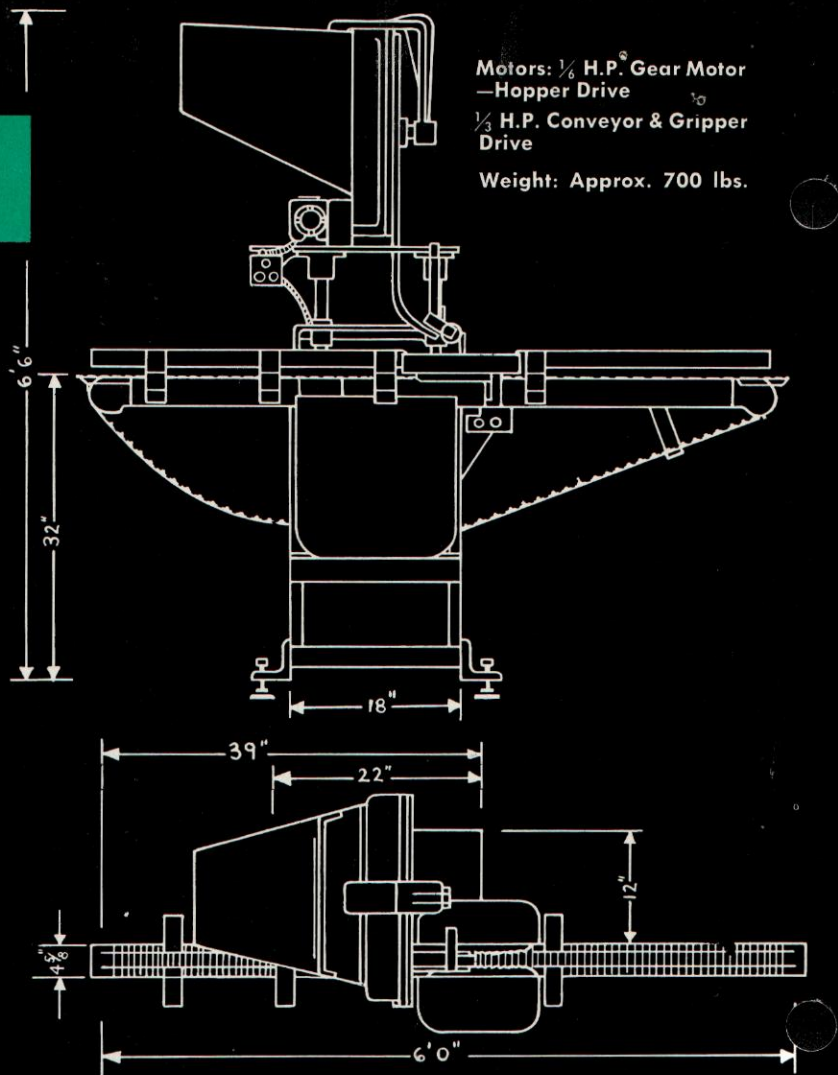

Model FA *fully automatic* FITMENT APPLICATOR

Consult a RESINA packaging and sealing specialist regarding your special problems. Our broad and varied experience is at your disposal.

RESINA AUTOMATIC MACHINERY COMPANY, INC.

572 Smith Street

Brooklyn 31, N. Y.

Represented by: