

VERTIC-L PP™

Laundry Bagging System

Rennco™
World-Class Packaging Solutions
a division of Pro Mach

Advantages

- Vertical film roll placement of centerfolded material for ease of roll change
- Maximum bag size capability 18" x 24"
- Increased efficiency with tool-less changeovers
- Produces trimless packages thus eliminating the need for a trim/scrap rewind system
- User-friendly HMI screen for setting selections
- Automatic machine cycling with light curtain mechanism

Description

Rennco's Vertic-L-PP laundry bagging system provides a reliable, versatile cost effective alternative to other roll stock systems or pre-made bag operations. Rennco has a 40 year tradition of innovation, experience and industry leading customer service and support.



(System shown with optional discharge conveyor and operator load platform)

Operational Summary

Towels are received into the hopper area from upstream equipment. Towels or shop rags advance towards the operator station. The operator "tosses" towels into the pouch area through the light screen which keeps track of the number of towels per bag. Once the count is reached, the machine will cycle and produce

the bag. The operator continues to load the next group of towels at the time the machine is cycling. This system offers ease of loading and increases production speed over current systems being used.



Finished package exits on conveyor to customer specified height.



Above: Interface panel shows correct product count.
Right: An ergonomically friendly platform raises the operator 20" from the floor.



The system inspection table makes sorting towels convenient. - table top measures 48" from the floor.



Vertic•L-PP Features

• Touch Screen	Recipe selection for package specifications
• Light Screen Auto Cycle	Allows for automatic machine cycling
• Vertical Film Roll Placement	Ease of changing roll stock material
• Trimless Package	No material scrap
• Bag Tapper	Assist distribution of products in package

Specifications

Standard Vertical Seal	18"
Standard Horizontal Seal	24"
Standard Jaw Opening	9 1/2"
Electrical Requirements	120V, 60hz, 1 ph 15amps*
Air Requirements	.6 CFM at 80 PSI

*Special electrics available upon request.

Bagger Dimensions

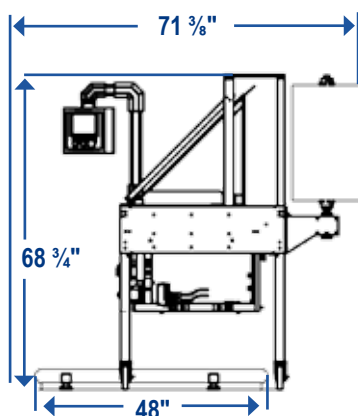

System Dimensions

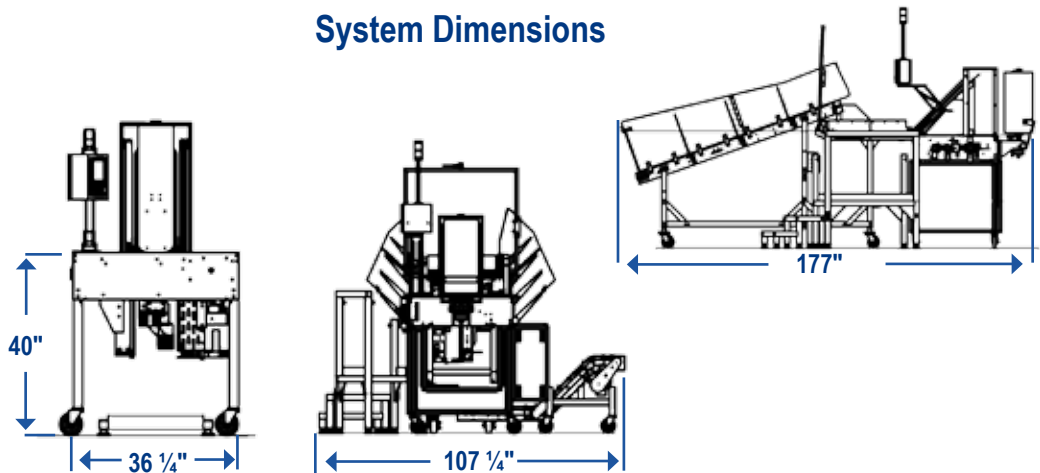

Go to www.rennco.com/vertic-l-pp for video or request a quote.

RenncoTM
World-Class Packaging Solutions
a division of Pro Mach

PO Box 116
300 Elm St.
Homer, MI 49245
USA
www.Rennco.com

Toll-Free: 800-409-5225
International: 517-568-4121
Fax: 517-568-4798
Email: sales@rennco.com

Packaging - Processing
Bid on Equipment
1-847-683-7720
www.bid-on-equipment.com