



Sympak

RC



CS 300/VSTR
Cartoning machine



TECHNICAL DATA - TECHNISCHE DATEN

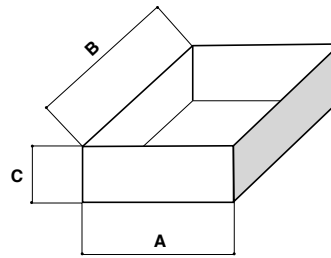
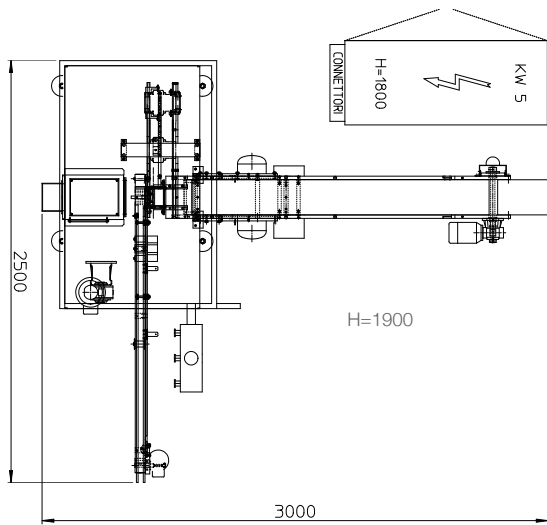

Standard product dimensions
Standard Produktabmessungen

CS 300 - CS 300/V			CS 300/VSTR/STR		
A	Min/Max	30/85 mm	A	Min/Max	50/90 mm
B	Min/Max	10/200 mm	B	Min/Max	65/200 mm
C	Min/Max	10/30 mm	C	Min/Max	10/30 mm
Production		10/250	Production		10/100
Leistung		pcs/minute	Leistung		pcs/minute
Net weight		1450 Kg	Net weight		1450 Kg
Netto Gewicht		1450 Kg	Netto Gewicht		1450 Kg
Gross weight		1800 Kg	Gross weight		1800 Kg
Brutto Gewicht		1800 Kg	Brutto Gewicht		1800 Kg
Absorption		Kw 2,3	Absorption		Kw 3
Absorption		Kw 2,3	Absorption		Kw 3

Automatic Cartoning Machine for small to medium sized products: runs off open flat blanks. Closed cartons with tucked and glued end flaps and glued longitudinal flap, by either cold or hot melt glue. Available in different infeed arrangements to suit specific product requirements. Optimised size tooling change to minimize production down times. Totally incorporated lubrication system, partly pipeline-fed and partly sunk in oil.

Automatischer Kartonierer für das Verpacken von Suppenwürfeln bzw. Produkte ähnlicher Größe.

Die CS300/VSTR arbeitet mit flachen, offenen, vorgestanzten Kartonzuschnitten, die aus einem Magazin entnommen und dann im Wrap-around-Verfahren um die gruppierten Produkte gefalteten werden. Dabei wird die Längsseite, sowie die Seitenlaschen entweder mittels Heißbleim oder Kaltbleim verklebt. Der Kartonierer weist eine hohe Flexibilität durch verschiedene Zuführungsmöglichkeiten auf und garantiert durch den einfachen Formatwechsel, dass die Stillstandzeit auf ein Minimum reduziert wird.

Die Schmierung der Maschine erfolgt über ein Ölbad.

PRODUCT CONFIGURATION - PRODUKTKONFIGURATION

1 3 Deck 2 Flap 1 Straps FF 2 Cubes - side by side 2 rows - 1 layer	2 4 Deck 2 Flap 1 Straps FF 4 Cubes - side by side 2 rows - 1 layer	3 6 Deck 2 Flap 1 Straps FF 6 Cubes - side by side 2 rows - 1 layer	4 8 Deck 2 Flap 1 Straps FF 8 Cubes - side by side 2 rows - 1 layer
5 10 Deck 2 Flap 1 Straps FF + TC 10 Cubes - side by side at end to end 2 rows - 1 layer	6 12 Deck 2 Flap 1 Straps FF + TC 12 Cubes - side by side at end to end 2 rows - 1 layer	7 14 Deck 2 Flap 1 Straps FF + TC 14 Cubes - side by side at end to end 2 rows - 1 layer	8 16 Deck 2 Flap 1 Straps FF + TC 16 Cubes - side by side at end to end 2 rows - 1 layer
9 18 Deck 2 Flap 1 Straps FF 18 Cubes - side by side 2 rows - 2 layers	10 12 Deck 2 Flap 2 Straps FF 12 Cubes - side by side 2 rows - 2 layers	11 16 Deck 2 Flap 2 Straps FF 16 Cubes - side by side 2 rows - 2 layers	12 20 Deck 2 Flap 2 Straps FF 20 Cubes - side by side 2 rows - 2 layers
13 24 Deck 2 Flap 2 Straps FF 24 Cubes - side by side 2 rows - 2 layers			



RC S.p.A.
Via Del Lavoro, 5
40050 Argelato (BO) - Italy
Phone: +39-051-6630514
Fax: +39-051-897140
Email: rcbologna@rcbologna.com
www.rcbologna.com



Packaging - Processing
Bid on Equipment
1-847-683-7720
www.bid-on-equipment.com