



replace all your refrigeration needs with the most energy-efficient, flexible, food-safe system...ever!
refrigerator, freezer, rapid chiller, safety thaw



FCSI
PRODUCT
INNOVATION
NOMINEE

KI
Kitchen Innovations
2007
AWARD
MEAT/POULTRY PROCESSOR
RESTAURANT, HOTEL/RESORT, GROCERY

Incorporating Adande® Technology

FX Series
refrigerated solutions
with flexicold technology





FX Series

refrigerated solutions
with flexicold technology

INTRODUCING...

a refrigeration system that doesn't expose your food to warm air or unsafe temperatures every time you access your product. No re-freezing or crystallization. No premature thawing. No cross-contamination or bacteria. No flavor transfer. No choosing one common temperature for all products.

The Original 2-N-1:

- Refrigerator (40°F)
- Freezer (-5°F)
- Or anywhere in between (-5° to 40°F)

The New 4-N-1:

- Refrigerator (40°F)
- Freezer (-5°F)
- Or anywhere in between (-5° to 40°F)
- **Rapid Chiller** for on-demand blast chilling
- **Safety Thaw** for on-demand safe thawing of frozen food

Introducing the FX Series – chilled by Randell's revolutionary FlexiCold Technology, giving you more precise control over your refrigerated storage than ever before.

Randell's FX Series' modular platform can be used in any point-of-use application. Pre-configured models include: Refrigerated Drawers, Cook-Top Systems, Preparation Work-Top Systems and Precision Storage Systems. Drawers operate independently, and users can switch from refrigerator to freezer– or anywhere in between. Or use it as a batch rapid chiller for cooling foods to below 40°F in 4 hours or less! The FX unit can also be used as a safety thaw system to thaw frozen foods safely and quickly while maintaining food below 40°F.



FX-2WS Preparation Work-Top System

When other systems claim they're better at keeping cold air with the food, it's just a lot of hot air. Traditional refrigeration systems all suffer from the same traditional problems. Open and close them again and again, and food is subject to re-freezing and crystallization, premature thawing, cross-contamination, even bacteria. All because the cold air isn't kept where it belongs – with the food. Designs change all the time, but the technology inside has been quietly thawing for years. Until now.

THE FX SERIES – NOTHING COMPARES.

	FX SERIES	TRADITIONAL SYSTEMS
<p>Flexible Refrigeration Install at point of preparation, even directly under grill or cook top, or seamlessly integrate into existing stands and equipment.</p>	Yes	No
Innovative design and insulated insert keep cold temperatures consistent.	Yes	No
<p>Drawer runners are completely outside the insulated storage area to...</p> <ul style="list-style-type: none"> · prevent freezing or binding. · permit insulated insert to be pulled all the way out. · allows 100% of the insulated insert to be used for food storage. 	Yes	No
Units can switch from <i>safety thaw</i> to <i>fridge</i> to <i>rapid chiller</i> to <i>freezer</i> with the simple adjustment of the control.	Yes	No
Innovative diffuser circulates cold air from the lid to all surfaces of the insulated insert, resulting in an unprecedented level of temperature control using minimum space.	Yes	No
Diffuser slots surround stored food, shielding it from potential heat invasion.	Yes	No
<p>Energy Efficiency Innovative design and insulated insert keep cold temperatures constant, which means less work for the compressor.</p>	Yes	No
Insulated insert holds cold air in place.	Yes	No
Magnet-to-magnet seal of lid to insert locks cold in while keeping warm air out.	Yes	No
Evaporator coil and fans turn off when unit is open, saving energy and preventing cold air from being pushed out of the unit.	Yes	No
According to the Energy Star rating system, FX Series would be in the top 1% of all products listed.	Yes	No
<p>Food Safety Consistent temperatures keep food safe and cold.</p>	Yes	No
Installed at point of preparation, lessening the prep time and chances of contamination or bacteria.	Yes	No
Insulated insert pulls out for easy cleaning and disinfecting.	Yes	No



FX-1 Refrigerated Drawer



FX-1CS Cook-Top System



FX-2CS Cook-Top System



FX-2WS Preparation Work-Top System



Two FX-2WS Preparation Work-Top System



FX-3SS Precision Storage System

FX Series

refrigerated solutions
with flexicold technology



100% storage capacity in the insulated insert.



28" deep x 22" wide, heavy duty ABS insulated insert.



Diffuser slots on insert surround food to shield from potential heat invasion.



Revolutionary FlexiCold Technology

Randell's patented FX Series with FlexiCold Technology revolutionizes point-of-use refrigeration in the United States. Whether operating as a refrigerator, freezer, rapid chiller or safety thaw, this new technology provides individual units with 100% cooling within each insulated insert. Temperatures remain consistent and energy is conserved no matter how many times the unit is opened and closed. Since cold remains in the insulated insert, food remains refrigerated and safe from dangerous bacteria and cross contamination.

Randell's FX Series provides the user with more control when it comes to refrigeration. Unlike traditional refrigeration, FlexiCold Technology ensures precise temperature control, and consistent temperatures and holding cycles – factors that positively impact food quality, food safety and energy efficiency.

The FX Series with FlexiCold Technology is flexible enough to be installed in the most convenient part of the kitchen due to its low power consumption — single 115v (15amp).

The Technology

Two key elements of the refrigeration design is the **lid** and the **insulated insert**. The lid seals against the flange of the insulated insert allowing 100% of conditioned air to surround product in the insert. The conditioned air stays in the insert and with the food.

The heavy duty ABS insulated insert provides full access to the product and 100% utilization of the 3 cubic feet of storage. Cool air flows from the diffuser to all surfaces of the drawer resulting in precise temperature control using minimum space. Traditional units block air flow when loaded, causing warm spots or frozen evaporator coils.

Since the air flow is contained inside the insulated insert, the drawer slides and inside shell are in ambient air so there is no frost build-up even at -5°F. And there is no food spillage on tracks to clean or interfere with compartment sliding.

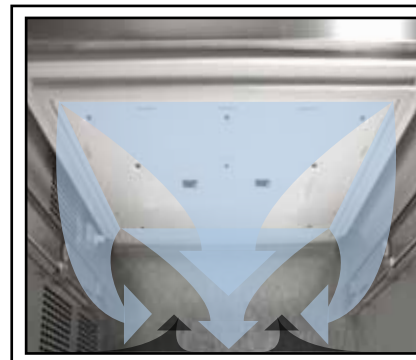

- Evaporator is behind the diffuser plate
- Horizontal seal surrounds lid (magnet-to-magnet)
- Return air fans are in the center of the lid
- Air diffuser supplies air evenly to insert (blue arrows)
- Cold air shield around food (blue arrows)
- Warm return air to evaporator (black arrows)

Energy Efficiency

The FX Series holds cold air in the insulated insert, keeping the cold air with the food even when left open for extended periods. The evaporator coil and fans turn off when the unit is open, saving energy. In traditional units, cold air pours out every time the unit is opened, wasting energy and losing cold.

THE COLD STAYS WITH THE FOOD, FX Series

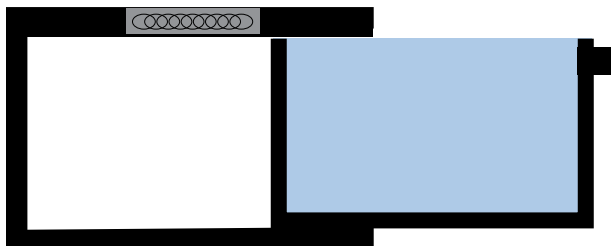

THE POUR-OUT EFFECT, Traditional Units

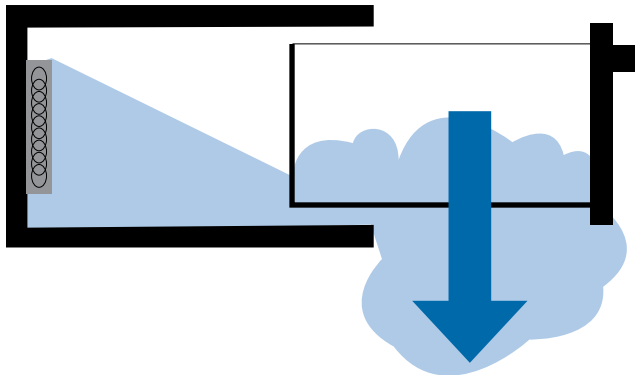

Food Safety

The FX Series has individual insulated inserts with controlled temperatures to eliminate cross-contamination and flavor transfer. A traditional unit shares common space thereby promoting cross-contamination and flavor transfer.

FX Series

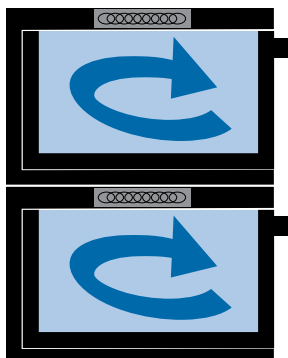

Traditional Units

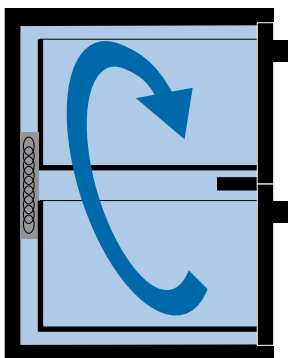

Inter-unit connectivity (up to 3 units) allows for single 115v (15amp) plug.



Fully front-breathing slide out refrigeration system allows for built-in designs. Easy to read and adjust temperature control is at your fingertips.



Flexible Applications.



The FX Series with FlexiCold Technology is the perfect refrigeration system for a wide variety of applications. Precise temperature controls allow the FX Series units to be used as either refrigerators or freezers, depending on the immediate need. Insulated inserts and an exclusive, innovative design keeps valuable cold air where it belongs – with the food.

- **Beef, pork, poultry** – keep at a soft freezing temperature for cutting without thawing and immediate, predictable cooking.
- **Sauces** – keep frozen to limit flavor-damaging refreezing and crystallization or messy dripping and cross-contamination.
- **Seafood** – store at a constant temperature to protect fresh taste, texture and consistency.
- **French fries & breaded products** – avoid ice crystals or premature thawing that can lead to excess moisture and loss of constitution.
- **Fruits & vegetables** – keep cold, fresh and crisp for as long as possible.
- **Ice cream, sorbet, pudding, gelatin & other desserts** – keep at the perfect temperature for the perfect consistency.
- **Refrigerated condiments** – maintain cold temperatures to prevent freezing or spoilage.
- **Bottled beverages** – easily accessible at the perfect temperature.

THE POUR-OUT EFFECT - PROOF THROUGH THERMAL IMAGING.

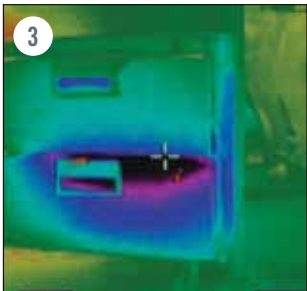
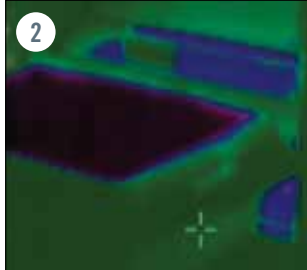

(1) A traditional designed drawer system allows the cold to “Pour-Out” onto the floor every time the product is accessed by the operator. The unit then must recover the lost temperature causing temperature degradation to occur. Throughout the day, the compounded effect leaves the temperature of the product higher than when the day started which affects the quality of the product, especially with fried foods where starting temperature is critical in maintaining consistent final product quality.

(2) The FX Series insert holds the cold as shown in this empty FX insulated insert. The cold comes up to the surface of the insert flange and stays there.

(3) Traditional units with vertical gaskets, as shown in this competitive brand product, lose cold while the unit is closed. The “Pour-Out” effect starts before you even access the product by opening the door or drawer.

(4) The FX Series unit in closed position shows no sign of air loss due to the unique and patented horizontal gasket seal between the lid and insulated insert.

4-N-1 CAPACITY.

Mode	Capacity	Pan Configuration Per Drawer	Average Thaw or Chill Time
Rapid Chiller	20 lbs.	(2) 12x20x2”	4 hours (contact factory for specific product cooling times)
Safety Thaw	20 lbs.	(2) 12x20x2”	6-8 hours
Refrigerator	90 lbs.	see page at right	-
Freezer	90 lbs.	see page at right	-



Model	L	D	H	No. of Drawers	Storage (cubic feet)	Comp. Size (per compartment)	Amp Draw (actual)	Power Usage (per compartment)		Volt	NEMA (per compartment)	BTU Rating (per compartment)		Ship Weight (lbs)
								Refrig./Chiller ⁵	Freezer/Thaw ⁵			Refrig.	Freezer	
FX-1	46"	28.6"	16.4"	1	3.0	5.5cc	3.9	1.22kw/day	1.99kw/day	115	5-15P	1018	522	245
FX1-4N1	46"	28.6"	16.4"	1	3.0	8.7cc	7.4	.46kw/hr ³	.15kw/hr ⁴	115	5-15P	1797	1018	250
FX-1CS ¹	48"	33"	22"	1	3.0	5.5cc	3.9	1.22kw/day	1.99kw/day	115	5-15P	1018	522	385
FX-2CS ¹	96"	33"	22"	2	6.0	5.5cc	7.8	1.22kw/day	1.99kw/day	115	5-15P	1018	522	770
FX-2WS ²	46"	29.6"	37.3"	2	6.0	5.5cc	7.8	2.44kw/day	3.98kw/day	115	5-15P	1018	522	635
FX-3SS ²	46"	29.6"	53.7"	3	9.0	5.5cc	11.7	3.66kw/day	5.97kw/day	115	5-15P	1018	522	891

¹ 22" High overall (3.5" casters), 21.75" to equipment surface ² 3.5" Casters ³ Based on average Chiller cycle time of 4 hours (actual power consumption only when in Chiller cycle)
⁴ Based on average Thaw cycle time of 6 hours (actual power consumption only when in Thawing cycle) ⁵ Chiller and Thaw power usage represent FX1-4N1 unit only

BULK STORAGE - 3 CUBIC FEET

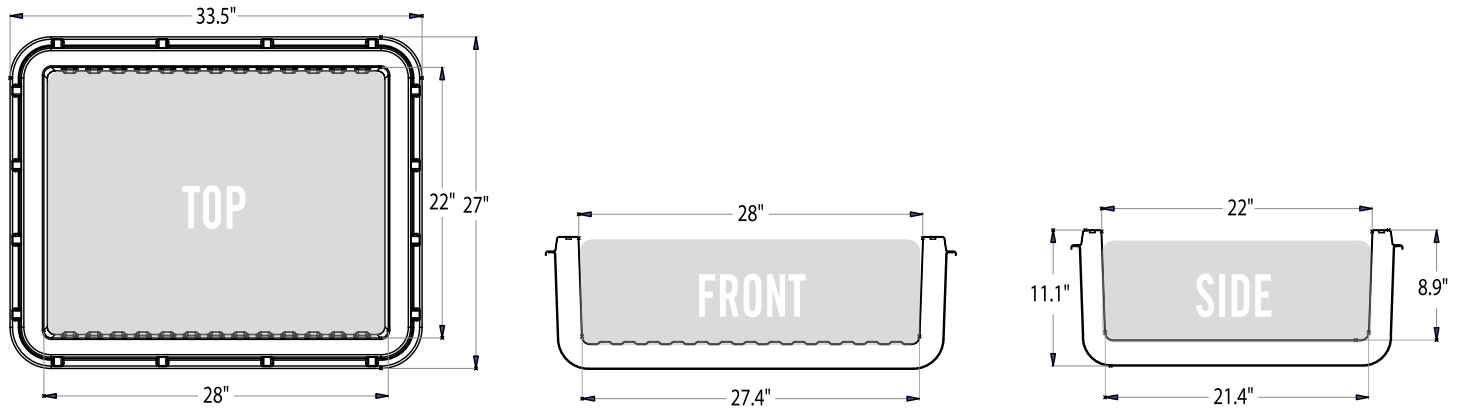

<p>(2) 12x20x6" DEEP HOTEL PANS</p>	<p>(2) 12x20x8" DEEP HOTEL PANS</p>	<p>(28) STANDARD WINE BOTTLES</p>
<p>(4) 12x20x4" DEEP HOTEL PANS (bottom two as back-up w/ lids on them)</p>	<p>(4) 1/2 SIZE 6" DEEP PANS</p>	<p>(6) ICE CREAM CONTAINERS (8-1/2" DIA. x 5" TALL)</p>
<p>(6) 1/3 SIZE 6" DEEP PANS</p>	<p>(2) PIZZA DOUGH BOXES (17.75" x 25.75") STACKED</p>	