



Blast Chiller Undercounter Refrigerator model BC-5E

Description:

If food safety is your concern, a Blast Chiller may be just what you need. The Randell BC-5E model is designed to fit into an operation where work surface is at a premium and can replace an existing 5' worktable. This model is designed to rapidly cool cooked items from a temperature of 140-160°F to 40°F in a time frame between 90-120 minutes (dependent on product density). The BC-5E Blast Chiller, along with the other models offered by Randell, provides the end user; enhanced product quality, improved shelf life (correctly chilled foods may be stored up to five days) and most importantly increased safety. 16A, 115V.

Specifications:

CAPACITY: (5) 12" x 20" x 2 1/2" stainless steel pans blast chilling from 140°F to 40°F at the core in (approx.) 90 minutes. Blast chilling from 160°F to 40°F at the core in (approx.) 120 minutes.

CABINET EXTERIOR: #4 finish Stainless Steel front, door, louver, sides and top. Unit back and bottom are galvanized metal.

CABINET INTERIOR: Stainless Steel, including Stainless Steel Air Plenums. Door opening perimeter is provided with an ABS thermal break to prevent sweating. A set of two Stainless Steel Pan Racks, designed to hold (4) 12" x 20" x 2 1/2" are removable without tools. The door is stainless steel exterior with a stainless steel liner and is mounted on concealed hinges with a full height stainless steel door pull. A press-fit magnetic gasket is provided for positive seal.

REFRIGERATION SYSTEM: The BC-5E is powered by a 3/4 Horsepower R-404a commercial temperature condensing unit connected to an interlaced evaporator coil. A high velocity fan provides, through dual Stainless Steel Air Plenums, a laminar air flow pattern across the product. The system is monitored through an electronic control. A printer is supplied to record operational performances and data. The unit is operated by sensing product temperature through the food probe that is provided as standard.

LAMINAR AIR FLOW: Our superior cross product air flow allows chilling of food product with pan covers on.



Standard Features:

- Stainless Steel Front, Sides & Top
- Stainless Steel Interior
- Removable Stainless Steel Pan Slides
- Life-time warranty on handles and hinges
- Stainless Steel Laminar Air Flow Plenum
- Superior Cross Product Air Flow
- Cooling with pan covers on to retain the product flavor
- Automatic Cooling System w/Food Probe
- Electronic Control w/Digital Read-Outs
- Automatic Condensate Evaporator
- 115V 20 amp plug-In Operation
- Self-Closing Door Hinge With 90° Positive Open Stop
- On Board Temperature Recording Device

Options & Accessories:

- Remote Operation
- Stainless Steel Finished Back
- Door Locks
- 4 1/4" Casters (2 with locks)
- Add Up to Two Probes

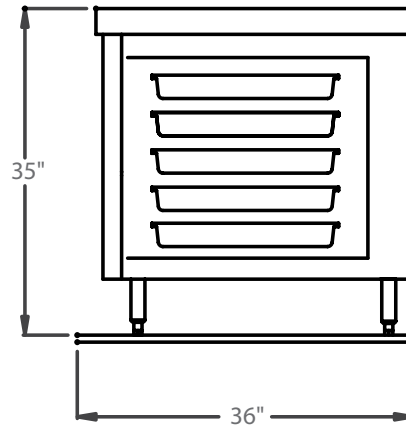
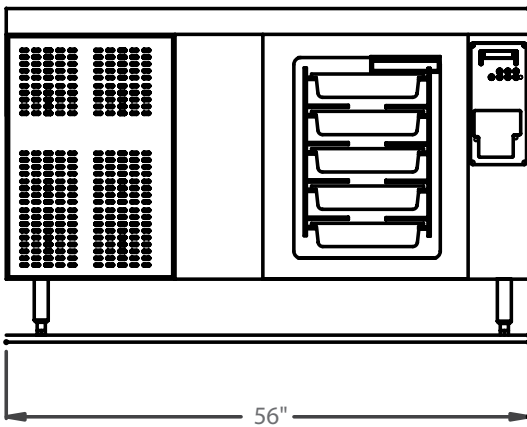
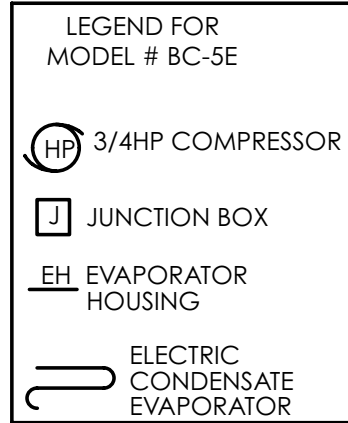
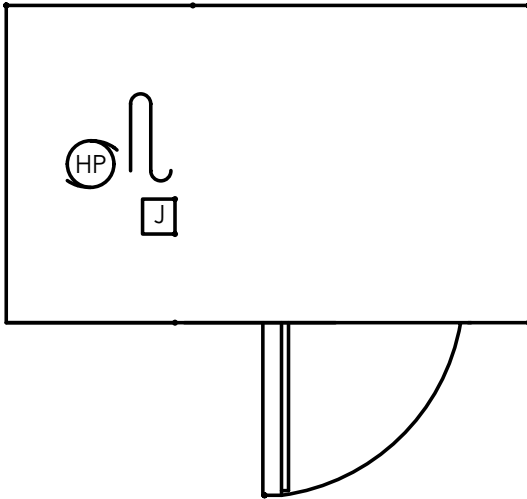

Model	L	D	H	12"x20"x2.5" Pan Capacity	LBS	HP	Amps. Min. Volt/Hz/Ph	Circuit Ampacity	NEMA	BTU Requirements for Remote Installations	Ship Wt.
BC-5E	56"	34"	36"	(5)	50	3/4	115/60/1	20	5-20P	6600 @ 20°F Evap. Temp.	450

