

Blast Chiller Undercounter Refrigerator model BC-10E

Description:

If food safety is your concern, a Blast Chiller may be just what you need. The Randell BC-10E model is designed to fit into an operation where work surface is at a premium and can replace an existing 6' worktable. This model is designed to rapidly cool cooked items from a temperature of 140-160°F to 40°F in a time frame between 90-120 minutes (dependent on product density). The BC-10E Blast Chiller, along with the other models offered by Randell, provides the end user; enhanced product quality, improved shelf life (correctly chilled foods may be stored up to five days) and most importantly increased safety. 16A, 115/208-230V, 1 phase.

Specifications:

CAPACITY: (10) 12" x 20" x 2 1/2" stainless steel pans blast chilling from 140°F to 40°F at the core in (approx.) 90 minutes. Blast chilling from 160°F to 40°F at the core in (approx.) 120 minutes.

CABINET EXTERIOR: #4 finish Stainless Steel front, door, louver, sides and top. Unit back and bottom are galvanized metal.

CABINET INTERIOR: Stainless Steel, including Stainless Steel Air Plenums. Door opening perimeters are provided with an ABS thermal break to prevent sweating. Two sets of two Stainless Steel Pan Racks, designed to hold (10) 12" x 20" x 2 1/2" pans are removable without tools. The door is stainless steel exterior with a stainless steel liner and is mounted on concealed hinges with a full height stainless steel door pull. A press-fit magnetic gasket is provided for positive seal.

REFRIGERATION SYSTEM: The BC-10E is powered by (1) 1 1/2 Horsepower R-404a commercial temperature condensing unit connected to interlaced evaporator coils. Dual high velocity fans provide, through a Stainless Steel Air Plenum, a laminar air flow pattern across the product. The system is monitored through an electronic control. A printer is supplied to record operational performance and data. The unit is operated by sensing product temperature through the food probe that is provided as standard.

LAMINAR AIR FLOW: Our superior cross product air flow allows chilling of food product with pan covers on.



Standard Features:

- Stainless Steel Front, Sides & Top
- Stainless Steel Interior
- Removable Stainless Steel Pan Slides
- Life-time warranty on handles and hinges
- Stainless Steel Laminar Air Flow Plenum
- Superior Cross Product Air Flow
- Cooling with pan covers on to retain the product flavor
- Automatic Cooling System w/Food Probe
- Electronic Control w/Digital Read-Outs
- Automatic Condensate Evaporator
- Self-Closing Door Hinge With 90° Positive Open Stop
- On Board Temperature Recording Device

Options & Accessories:

- Remote Operation
- Stainless Steel Finished Back
- Door Locks
- 4 1/4" Casters (2 with locks)
- Add Up to Four Additional Probes

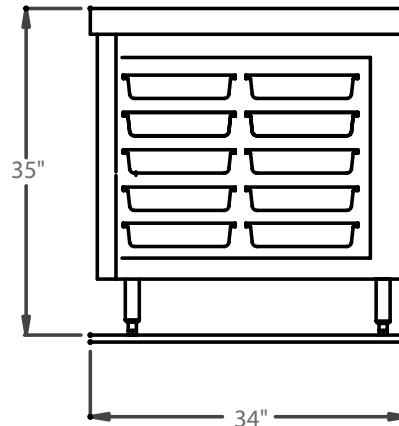
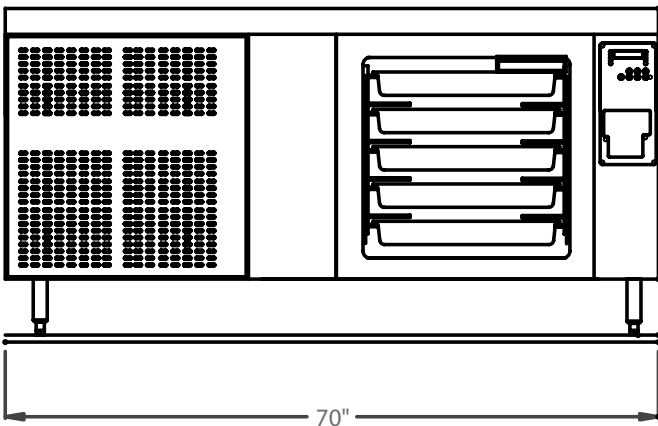
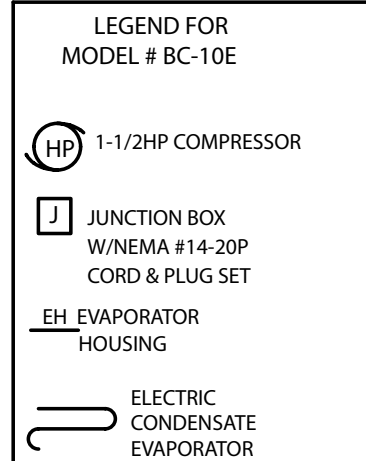
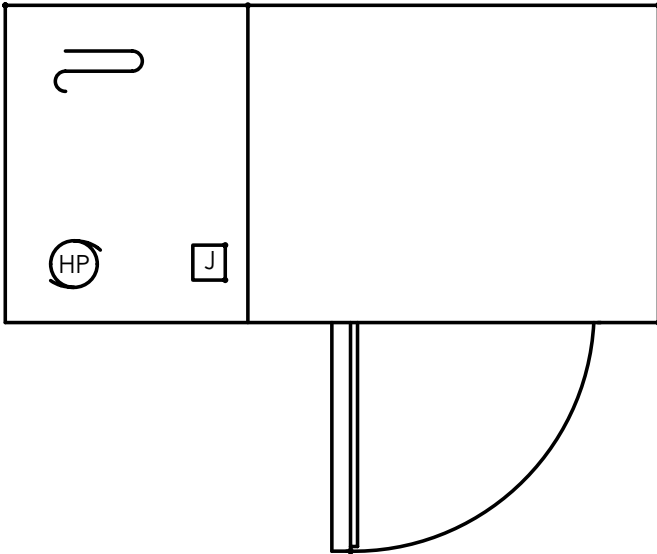

| Model | L | D | H | 12"x20"x2.5" Pan Capacity | LBS | HP | Amps. Min. Volt/Hz/Ph | Circuit Ampacity | NEMA | BTU Requirements for Remote Installations | Ship Wt. |
|--------|-----|-----|-----|------------------------------|-----|-------|--------------------------|---------------------|-------------------------|--|-------------|
| BC-10E | 70" | 34" | 36" | (10) | 100 | 1 1/2 | 115/208-230/60/1 | 20 | 4 Wire Direct 14-20P | 12100 @ 20°F Evap. Temp. | 550 |

