

OPERATORS MANUAL

This manual provides
Installation & Operating instructions for

DROP-IN HOT/COLD WELL 9580 SERIES



NOTIFY CARRIER OF DAMAGE AT ONCE.

It is the responsibility of the consignee to inspect the container upon receipt of same and to determine the possibility of any damage, including concealed damage. Randell suggests that if you are suspicious of damage to make a notation on the delivery receipt. It will be the responsibility of the consignee to file a claim with the carrier. We recommend that you do so at once.

Manufacture Service/Questions 888-994-7636.

Information contained in this document is known to be current and accurate at the time of printing/creation. Unified Brands recommends referencing our product line websites, unifiedbrands.net, for the most updated product information and specifications.



1055 Mendell Davis Drive
Jackson, MS 39272
888-994-7636, fax 888-864-7636
randell.com

CONTENTS

Factory Correspondence	2
Randell Warranty.....	3,4
Unit Specifications.....	5
Serial Number Location.....	5
Unit Installation.....	6
Unit Operation.....	7,8
Preventative Maintenance.....	8
Troubleshooting	9
Replacement Parts.....	10

Congratulations on your recent purchase of Randell food service equipment, and welcome to the growing family of satisfied Randell customers.

Our reputation for superior products is the result of consistent quality craftsmanship. From the earliest stages of product design, to successive steps in fabrication and assembly, rigid standards of excellence are maintained by our staff of designers, engineers, and skilled employees.

Only the finest heavy-duty materials and parts are used in the production of Randell brand equipment. This means that each unit, given proper maintenance, will provide years of trouble free service to its owner.

In addition, all Randell food service equipment is backed by one of the best warranties in the food service industry and by our professional staff of service technicians.

Retain this manual for future reference.

Notice: Due to a continuous program of product improvement, Randell Manufacturing reserves the right to make changes in design and specifications without prior notice.

Notice: Please read the entire manual carefully before installation.
If certain recommended procedures are not followed, warranty claims will be denied.

Model Number _____

Serial Number _____

Installation Date _____

**Randell Manufacturing
Service and Parts
Hot Line
1-800-621-8560
or for our
Service Agent Listings
visit our web site at
www.randell.com**

Warranty Policies

Parts Warranty

Randell warrants all component parts of manufactured new equipment to be free of defects in material and workmanship, and that the equipment meets or exceeds reasonable industry standards of performance for a period of one year from the date of shipment from any Randell factory, assembly plant or warehouse facility.

Note: Warranties are effective from date of shipment, with a thirty day window to allow for shipment, installation and set up. In the event equipment was shipped to a site other than the final installation site, Randell will warranty for a period of three months following installation, with proof of starting date, up to a maximum of eighteen months from date of purchase.

Component parts warranty does not cover glass breakage. Randell covers all shipping cost related to component part warranty sent at regular ground rates (UPS, USPS). **Freight or postage incurred for any express or specialty methods of shipping are the responsibility of the customer.**

Labor Coverage

In the unlikely event a Randell manufactured unit fails due to defects in materials or workmanship within the first ninety days, Randell agrees to pay reasonable labor incurred. During the first ninety days work authorizations are not required for in warranty repairs. However, repair times are limited to certain flex rate schedules and hours will be deducted from service invoices if they exceed allowed times without prior approval and a work authorization number. Warranties are effective from date of shipment, with a 30 day window to allow for shipment, installation and setup.

Where equipment is shipped to any site other than final installation Randell will honor the labor warranty for a period of ninety days following installation with proof of starting date, up to a maximum of nine months from date of purchase. Travel time is limited to one hour each direction or two hours per invoice.

Any travel time exceeding two hours will be the responsibility of the customer.

Export Warranty

Our export warranties will cover all non electrical parts for the period of one year from the date of shipment to be free of defects in material or workmanship. Electrical parts are also covered if ordered and operated on 60 Hz. Electrical components, ordered and operated on 50 Hz, are warranted for the first 90 days from shipment only. Service labor is covered for the first 90 days with authorization from factory prior to service. Warranty is automatically initiated 60 days from ship date. Inbound costs on any factory supplied items would be the responsibility of the customer. Adherence to recommended equipment maintenance procedures, according to the owners manual provided with each unit, is required for this warranty to remain in effect, and can have a substantial effect on extending the service life of your equipment. Equipment abuse voids any warranty. Extended warranties are not available for parts or labor on units shipped outside the United States.

Five Year Extended Compressor Warranty

United States installation only:

Randell will pay for the replacement compressor only. Freight, labor, refrigerant, handling, and all other miscellaneous charges are the responsibility of the customer. Randell will fulfill its warranty obligation by using one of the four methods provided below, which will be selected by the Randell in-house service technician.:

1. Provide reimbursement to servicing customer for the cost of the locally obtained replacement compressor in exchange for the return of the defective compressor to Randell returned freight prepaid. Randell does limit the amount of reimbursement allowed and does require a copy of the local supply house bill for the replacement compressor.

Customer should not pay servicing agent up front for the replacement compressor.

2. Provide repair at manufacturing facility by requiring that the defective unit be sent back to Randell freight prepaid. Repair will be performed at the expense of Randell and the unit shipped to job location freight collect.

3. Furnish a replacement compressor freight collect in exchange for the return of the defective compressor sent back freight prepaid.

4. Furnish complete condensing unit or replacement package freight collect in exchange for the return of the defective compressor sent back to Randell prepaid. (Decision on whether or not to send the complete condensing unit will be made by Randell in-house service technician)

Freight Damage

Any and all freight damage that occurs to a Randell piece of equipment as a result of carrier handling is not considered warranty, and is not covered under warranty guidelines. Any freight damage incurred during shipping needs to have a freight claim filed by the receiver with the shipping carrier (note all damages on freight bill at time of delivery). Internal or concealed damage may fall under Randell's responsibility dependent upon the circumstances surrounding each specific incident and are at the discretion of the Randell in-house service technician.

NOTICE: FOOD LOSS IS NOT COVERED UNDER WARRANTY

Unit Installation

A. Receiving Shipment

Upon arrival, examine the exterior of the shipping crate for signs of abuse. It is advisable that the shipping crate be partially removed, in order to examine the cabinet for any possible concealed damages which might have occurred during shipment. If no damages are evident, replace the crate in order to protect the unit during storage and local delivery. If the unit is damaged, it should be noted on the delivery slip or bill of lading and signed to that effect. A claim must be filed immediately against the carrier indicating the extent and estimated cost of damage occurred.

B. Locating Your New Unit

The following conditions should be considered when selecting a location for your unit:

- Floor and Counter top load - The area on which the unit will rest must be free of vibration and suitably strong enough to support the combined weights of the unit plus the maximum product load weight.
- 2. Clearance - There must be a combined total of at least 3" clearance on all sides of the unit.
- 3. Ventilation - The air cooled self contained units requiring a sufficient amount of cool clean air. Avoid placing the unit near heat generating equipment such as ovens, ranges, heaters, fryers, steam kettles, etc. and place out of direct sunlight. Avoid locating the make table in an unheated room or where the room temperature may drop below 55° F or above 90° F. Our drop in cold pans need cross flow ventilation with at least 336 square inches per opening.

C. Electrical Supply

The wiring should be done by a qualified electrician in accordance with local electrical codes. A properly wired, and grounded outlet will assure proper operation. Please consult the data plate attached to the control panel to ascertain the correct supply voltage and amperage requirements of the unit.

NOTE: It is important that a voltage reading be made at the compressor motor electrical connections while the unit is in operation to verify that the correct voltage required by the is being supplied. Low or high voltage can detrimentally affect operation and so void the warranty.

D. Installation Checklist

After the final location of the unit has been determined refer to the following checklist prior to start up:

1. Check all wiring and refrigeration lines to ensure that there are no kinked, bare, or loose wires.
2. Check that unit fits properly in cabinet and ensure that it is properly leveled.
3. Check that condenser fans rotate freely without striking any stationary members.
4. Plug in unit and turn on main switch.
5. Refer to the front of this manual for serial number location. Please record this information in your manual. It will be necessary when ordering replacement parts or requesting warranty service.
6. Allow your unit to operate approximately one hour before putting in food. This allows a proper frost pattern to form.
7. Confirm that unit is holding temperature. Set controls to desired holding temperature.

NOTE: All motors are oiled and sealed at the factory.

UNIT SPECIFICATIONS

MODEL	L	D	UNIT	CONTROL PANEL	# OF ELEMENTS	
9580-2	31.125"	26"	27.75" X 22.5"	14" X 5.75"	1	
9580-3	43.625"	26"	40.25" X 22.5"	14" X 5.75"	2	
9580-4	56.5"	26"	53" X 22.5"	14" X 5.75"	3	
9580-5	69.25"	26"	65.75" X 22.5"	14" X 5.75"	4	
			AMPS / 60Hz / 1 PH			
MODEL	WATTAGE	HP	120V (REF)	208V (HTD)	240V (HTD)	SHIP WT (LBS)
9580-2	1100	1/4	7.1	5.3	4.5	110
9580-3	2200	1/4	7.1	10.6	9.2	135
9580-4	3300	1/4	7.1	15.9	13.8	160
9580-5	4400	1/4	7.1	21.2	18.3	185

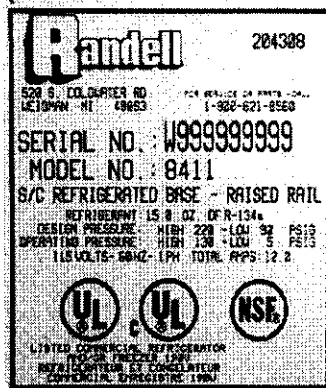

**RANDELL MANUFACTURING
 SERIAL NUMBER LOCATION
 FOR THE
 DROP-IN SERIES**

This is a sample of a serial number tag.

The serial number tag on the refrigerated units is located on the front of the control panel.

UNIT OPERATION

The 9580Drop In unit is designed to operate as either a cold pan unit or as a hot food table. Mode of operation is determined by the position of the three-way switch on the control panel (HOT/OFF/COLD).

NOTE: When switching between hot and cold operations, allow the unit to warm up or cool down accordingly. This will save wear and tear on the components of your drop in unit, particularly the compressor when changing from hot to cold operation.

OPERATION AS A COLD FOOD WELL

Randell has attempted to preset the cold temperature control for an average temperature at the factory but, due to varying conditions (i.e. elevation, food product, type of operation, etc.), you may need to alter this temperature. Additional adjustments can be made (within limits) by turning the control dial up to down until the desired temperature is reached. The control knob is located on the unit base by the compressor.

The control knob allows for temperature adjustments. Turning the knob clockwise will result in increased cooling. Keep the arrow on the knob pointed within the green arc. Turning it clockwise beyond the green can result in freeze-up, while turning it counterclockwise beyond the green arc will shut the compressor off. If your cold pan temperature remains too warm and your temperature control is at the maximum setting, please contact your service technician.

Note: Drains must be plumbed to all applicable local code requirements.

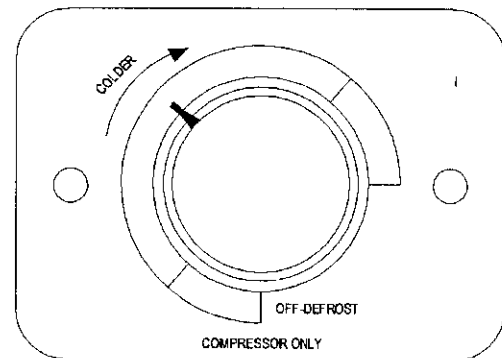

Caution: Moisture collecting from improper drainage can create a slippery surface on the floor and a hazard to employees. When making electrical connections refer to the amperage data listed on the units data plate. Your local code or the national electrical code handbook to be sure the unit is connected to the proper power source.

Morning Start-up

1. Rail cleaning may be performed at this time.
2. Once rail is cleaned and prepared for product, turn on the unit with the switch located on the base by the compressor.
3. Allow 25 minutes for unit to cool down before loading product. (If unit is started at the full off position, 30-45 minutes may be necessary for unit to cool down.)
4. Load the product and proceed with food preparation.

Evening Shutdown

1. Remove product from rail at the end of the day's preparation.
2. Turn off the rail with the switch located on the base by the compressor.
3. Cleaning may be performed at this time if the frost has melted off the rail surface.

OPERATION AS A HOT FOOD TABLE

All units are designed for 145° to 175° operation or 140° to 170° product temperature.

Plumbing: The units drain must have an outlet to an appropriate drainage area or container. Open well units with exposed heating elements require spillage pans to operate properly.

Note: Electric elements are not submersible.

Note: Drains must be plumbed to all applicable local code requirements.

Caution: Moisture collecting from improper drainage can create a slippery surface on the floor and a hazard to employees. When making electrical connections refer to the amperage data listed on the units data plate. Your local code or the national electrical code handbook to be sure the unit is connected to the proper power source.

PREVENTATIVE MAINTENANCE

Randell strongly suggests a preventive maintenance program which would include the following **Monthly** procedures:

1. Clean your unit with a solution of warm water and a mild detergent. The stainless steel portion of your unit can be polished with any quality polish.
2. Drain water from wells daily and wipe them out. Clean wells thoroughly twice a week to help insure a longer life for your wells.

Note: Do not use chemicals, steel wool or scrapers to clean unit.

Caution: Do not use abrasive cleaning solvents.

Proper maintenance of equipment is the ultimate necessity in preventing costly repairs. By evaluating each unit on a regular schedule you can often catch and repair minor problems before they completely disable the unit and become burdensome on your entire operation. For more information on preventive maintenance consult your local service company or www.CFESA.com. Most repair companies offer this service at very reasonable rates to allow you the time you need to run your business along with the peace of mind that all your equipment will last throughout its expected life. These services often offer guarantees as well as the flexibility in scheduling of maintenance for your convenience. Randell believes strongly in the products it manufacturers and backs those products with one of the best warranties in the industry. We believe with the proper maintenance and use you will realize a profitable return on your investment and years of satisfied service.

TROUBLESHOOTING GUIDE FOR ELECTRIC HOT FOOD TABLES

An electric hot food table operates on 120V, 208V or 240V circuits. It draws power through either a fuse or circuit breaker panel; if you suspect an electrical problem, check there first. The heating elements are controlled by electrical temperature controls which sense and regulate temperature.

The following trouble shooting guide list the most common malfunctions in order from most to least likely.

PROBLEM	POSSIBLE CAUSE	REMEDY
Unit will not heat	1. Thermostat off	1. Turn on
	2. Unit unplugged	2. Plug in unit
	3. Circuit breaker tripped	3. Replace breaker
	4. Unknown problem	4. Call service agency
Individual well will not heat	1. Thermostat off	1. Turn on
	2. Unknown	2. Call service agency

ITEM	DESCRIPTION	UNITS	PART NUMBER
1	LOUVER, FLAT 18" X 22"	9580	RP LVR0019
2	CONTROL PANEL*	9580 SERIES	RP CNT003
3	CONTROL KNOB	9580 SERIES	HD KNB0003
3A	TEMPERATURE CONTROL (HOT)	9580 SERIES	EL HFT0201
3A	TEMPERATURE CONTROL (HOT)	9580-5A	EL HFT230-96
3B	GUARD, HFT CONTROL	9580 SERIES	HD GRD0203
4	INDICATOR LIGHT	9580 SERIES	EL LGT500
5A	SWITCH	2,3,4 WELL UNITS	EL SWT1286
5	SWITCH	9580-5A	EL SWT1288
6A	PERFORATED PAN, 12.5" X 19.5"	9580-2A	RP PPN0003
6B	PERFORATED PAN, 18.75" X 19.5"	9580-3A	RP PPN0004
6C	PERFORATED PAN, 25" X 19.5"	9580-4A	RP PPN0005
6D	PERFORATED PAN, 31.5" X 19.5"	9580-5A	RP PPN0008
7A	ELEMENT, 208V/1100WATT	9580 SERIES	RP ELM9560B
7B	ELEMENT, 240V/1100WATT	9580 SERIES	RP ELM9560C
8A	ELEMENT PAN ASSY, W/208V ELEMENT	9580 SERIES	RP PAND18
8B	ELEMENT PAN ASSY, W/240V ELEMENT	9580 SERIES	RP PAND19
8C	ELEMENT PAN ASSY, W/OUT ELEMENT	9580 SERIES	RP PAND21
9	DRAIN SCREEN	9580 SERIES	RP DSN001
10	GATE VALVE, 1" THREADED	9580 SERIES	PB VLV1000
11A	CAP TUBING W/DRYER .036ID X .96"	9580 SERIES	RP CAP014
11B	CAP TUBING W/DRYER .036ID X 1.44" R404**	9580 SERIES	RP CAP023
12	FILTER DRYER, 1/4" X .042 ID	9580 SERIES	RF FLT9902
13	TEMP CONTROL (COLD)	9580 SERIES	HD CNT.9902
14	COIL, CONDENSER	9580 SERIES	RF CND005EL
15	MOTOR, COND FAN	9580 SERIES	EL MTR300EL
16	BLADE, CONDENSER FAN MOTOR	9580 SERIES	RF FAN008EL
17A	CONDENSING UNIT, 1/4HP LOTEMP R134	9580 SERIES	RF CND0001
17B	CONDENSING UNIT, 1/4HP LOTEMP R404**	9580 SERIES	RF CND0104
18A	COMPRESSOR, 1/4 HP LO TEMP R134	9580 SERIES	RF CMP015
18B	COMPRESSOR, 1/4 HP LOTEMP R404**	9580 SERIES	RF CMP0201P

*SHEET METAL PARTS ONLY - ORDER BUYOUT PARTS SEPARATELY
 **PARTS WITH R404 REFRIGERANT

