

## OPERATORS MANUAL

This manual provides  
Installation & Operating instructions for

# **9000K-7 SERIES HIGH VOLUME SALADTOP REFRIGERATORS**



### **NOTIFY CARRIER OF DAMAGE AT ONCE.**

It is the responsibility of the consignee to inspect the container upon receipt of same and to determine the possibility of any damage, including concealed damage. Avtec suggests that if you are suspicious of damage to make a notation on the delivery receipt. It will be the responsibility of the consignee to file a claim with the carrier. We recommend that you do so at once.

Manufacture Service/Questions 888-994-7636.



1055 Mendell Davis Drive  
Jackson, MS 39272  
888-994-7636, fax 888-864-7636  
unifiedbrands.net

## TABLE OF CONTENTS

Page 2 .....	Congratulations
Page 2 .....	Factory Correspondence
Page 3 .....	Serial Number Location
Page 3 .....	Unit Specifications
Page 4 .....	Randell Limited Warranty
Page 5 .....	Unit Installation
Page 7 .....	Unit Operation
Page 7 .....	Preventative Maintenance
Page 9 .....	Troubleshooting
Page 15 .....	Part Diagrams

Congratulations on your recent purchase of Randell food service equipment, and welcome to the growing family of satisfied Randell customers.

Our reputation for superior products is the result of consistent quality craftsmanship. From the earliest stages of product design, to successive steps in fabrication and assembly, rigid standards of excellence are maintained by our staff of designers, engineers, and skilled employees.

Only the finest heavy-duty materials and parts are used in the production of Randell brand equipment. This means that each unit, given proper maintenance, will provide years of trouble free service to its owner.

In addition, all Randell food service equipment is backed by one of the best warranties in the food service industry and by our professional staff of service technicians.

Retain this manual for future reference.

**Notice:** Due to a continuous program of product improvement, Randell Manufacturing reserves the right to make changes in design and specifications without prior notice.

**Notice:** Please read the entire manual carefully before installation.  
If certain recommended procedures are not followed, warranty claims will be denied.

Model Number \_\_\_\_\_  
Serial Number \_\_\_\_\_  
Installation Date \_\_\_\_\_

**Randell Manufacturing  
Service and Parts  
Hot Line  
1-800-621-8560  
or for our  
Service Agent Listing  
visit our web site at  
www.randell.com**

**RANDELL MANUFACTURING  
SERIAL NUMBER LOCATION  
FOR THE  
9000K-7 SERIES**

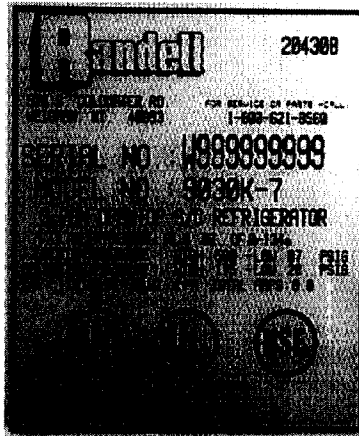

This is just a sample serial number tag.

The serial number tag on the 9000K-7 series is located in the far left refrigerated door in the base of the unit. On the CR9000 series units it is located on the far right side on the compressor housing cover.

**Unit Specifications  
For The  
9000K-7 Series**

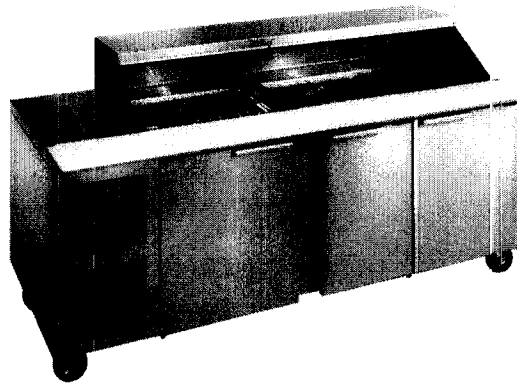

**9000K-7 SERIES**

MODEL	L	D	H	DOORS	STORAGE CU. FT.	CONDIMENT PAN CAPACITY**	Hp	VOLT	AMP	NEMA	Ship Wt.
9030K-7	50"	33"	35***	(2)18"	7.67	(3) 12 X 20	1/3	115/60/1	8.5	5-15P	335
9040K-7	62"	33"	35***	(2)24"	11.2	(4) 12 X 20	1/3	115/60/1	8.5	515P	430
9045K-7	74"	33"	35***	(2)27"	11.2	(5) 12 X 20	1/2	115/60/1	12	5-15P	475
9050K-7	86"	33"	35***	(2)24" (1)18"	16.8	(5) 12 X 20	1/2	115/60/1	12	5-15P	520

## Warranty Policies

### Parts Warranty

Randell warrants all component parts of manufactured new equipment to be free of defects in material or workmanship, and that the equipment meets or exceeds reasonable industry standards of performance for a period of one year from the date of shipment from any Randell factory, assembly plant or warehouse facility.

**Note: Warranties are effective from date of shipment, with a thirty day window to allow for shipment, installation and set up. In the event equipment was shipped to a site other than the final installation site, Randell will warranty for a period of three months following installation, with proof of starting date, up to a maximum of eighteen months from date of purchase.**

Component parts warranty does not cover glass breakage or gasket replacement. Randell covers all shipping cost related to component part warranty sent at regular ground rates (UPS, USPS). Freight or postage incurred for any express or specialty methods of shipping are the responsibility of the customer.

### Labor Coverage

In the unlikely event a Randell manufactured unit fails due to defects in materials or workmanship within the first ninety days, Randell agrees to pay reasonable labor incurred. During the first ninety days work authorizations are not required for in warranty repairs. However, repair times are limited to certain flex rate schedules and hours will be deducted from service invoices if they exceed allowed times without prior approval and a work authorization number. Warranties are effective from date of shipment, with a 30 day window to allow for shipment, installation and setup.

Where equipment is shipped to any site other than final installation Randell will honor the labor warranty for a period of ninety days following installation with proof of starting date, up to a maximum of nine months from date of purchase.

**Temperature adjustments are not covered under warranty**, due to the wide range of ambient conditions. Travel time is limited to one hour each direction or two hours per invoice. Any travel time exceeding two hours will be the responsibility of the customer.

### Five Year Extended Compressor Warranty

When the optional five year compressor warranty is purchased:

Randell will pay for the replacement compressor only. Freight, labor, freon, handling and all other miscellaneous charges are the responsibility of the customer. Randell will fulfill its warranty obligation by using one of the four methods provided below, which will be selected by the Randell in house service technician:

Provide reimbursement to servicing customer for the cost of the locally obtained replacement compressor in exchange for the return of the defective compressor returned to Randell freight prepaid. Randell does limit the amount of reimbursement allowed and does require a copy of the local supply house bill for replacement compressor. (Customer should not pay servicing agent up front for compressor)

Provide repair at the manufacturing facility by requiring that the defective unit be sent back to Randell freight prepaid. Perform repair at the expense of Randell and ship the item back to job location freight collect.

Furnish a replacement compressor freight collect in exchange for the return of the defective compressor sent back freight prepaid.

Furnish complete condensing unit or replacement package freight collect in exchange for the return of the defective compressor sent back freight prepaid. (decisions based on whether or not to send complete condensing unit will be made by Randell in-house service technician).

### Freight Damage

Any and all freight damage that occurs to a Randell piece of equipment as a result of carrier handling is not considered warranty, and is not covered under warranty guidelines. Any freight damage incurred during shipping needs to have a freight claim filed by the receiver with the shipping carrier (note all damages on freight bill at time of delivery). Internal or concealed damage may fall under Randell's responsibility dependent upon the circumstances surrounding each specific incident and are at the discretion of the Randell in-house service technician.

## **Gasket Coverage**

Randell does not cover gaskets under warranty. Gaskets are a maintenance type component that are subject to daily wear and tear and are the responsibility of the owner of the equipment. Because of the unlimited number of customer related circumstances that can cause gasket failure all gasket replacement issues are considered non-warranty. Randell recommends thorough cleaning of gaskets on a weekly basis with a mild dish soap and warm water. With proper care Randell gaskets can last up to three years, at which time we recommend replacement of all gaskets on the equipment for the best possible performance.

## **Notice: FOOD LOSS IS NOT COVERED UNDER WARRANTY**

Our export warranties will cover all non electrical parts for the period of one year from the date of shipment to be free of defects on material and workmanship. Electrical parts are also covered if ordered and operated on 60 Hz. Electrical components, ordered and operated on 50 Hz, are warranted for the first 90 days from shipment only. Service labor is covered for the first 90 days with authorization from factory prior to service. Warranty is automatically initiated 60 days from ship date. Inbound costs on any factory supplied items would be the responsibility of the customer. Adherence to recommended equipment maintenance procedures, according to the owners manual provided with each unit, is required for this warranty to remain in effect, and can have a substantial effect on extending the service life of your equipment. Equipment abuse voids any warranty. Extended warranties are not available for parts, labor or compressors on units shipped outside the United States.

## **Unit Installation**

### **A. Receiving Shipment**

Upon arrival, examine the exterior of the shipping crate for signs of abuse. It is advisable that the shipping crate be partially removed, in order to examine the cabinet for any possible concealed damages which might have occurred during shipment. If no damages are evident, replace the crate in order to protect the unit during local delivery. If the unit is damaged, it should be noted on the delivery slip or bill of lading and signed to that effect. A claim must be filed immediately against the carrier indicating the extent and estimated cost of damage occurred.

### **B. Locating Your New Unit**

The following conditions should be considered when selecting a location for your unit:

Floor or Countertop load - The area on which the unit will rest must be free of vibration and suitably strong enough to support the combined weights of the unit plus the maximum product load weight, it is generally acknowledged that a safe figure is 35lbs. For each net cubic foot of storage space (example, a 47 cubic foot cabinet could hold approximately 1645lbs. of product 47 X 35= 1645).

Clearance - There must be at least a 3" clearance on all sides of the unit.

Ventilation - The air cooled self contained unit requires a sufficient amount of cool clean air. Avoid placing the unit near heat generating equipment such as ovens, ranges, heaters, fryers, steam kettles, etc. and out of direct sunlight. Avoid locating the make table in an unheated room or where the room temperature may drop below 55° F or above 90° F.

### **C. Electrical Supply**

The wiring should be done by a qualified electrician in accordance with local electrical codes. A properly wired, and grounded outlet will assure proper operation. Please consult the data plate attached to the compressor to ascertain the correct electrical requirements. Supply voltage requirements are located on the serial number tag.

**Note: It is important that a voltage reading be made at the compressor motor electrical connections, while the unit is in operation, to verify that the correct voltage required by the compressor is being supplied. Low or high voltage can detrimentally affect operation and thereby void its warranty.**

**Note: It is important that your unit has its own dedicated line. Condensing units are designed to operate with a voltage fluctuation of plus or minus 10% of the voltage indicated on the unit data plate. Burn out of a condensing unit due to exceeding voltage limits will void the warranty.**

## D. Door Inspection

Check doors and drawers to insure that they are sealing properly and that they are aligned (see diagram D).

Note: For units supplied with self closing doors (see diagram C).

## E. Installation Checklist

After the make table has been installed refer to the following checklist prior to start up:

1. Check all exposed refrigeration lines to ensure that they are not kinked, dented or rubbing together.
2. Check that condenser and evaporator fans rotate freely without striking any stationary members.
3. Unit must be properly leveled (see diagram A).
4. Refer to the front of this manual for serial number location. Please record this information in your manual now. It will be necessary when ordering replacement parts or requesting warranty service.
5. Confirm that unit is holding temperature. Set controls to desired temperature for your particular ambient and altitude (See diagram B.).
6. Drop-in units must have 405 square inches of cross flow ventilation per side. Equal to or greater than the louvers provided with each unit at time of purchase.
7. Check defrost setting for both number of defrosts and time of defrost activation.
  - a. Standard hooded roll top covers must remain in place to provide NSF Standard 7 product temperatures of 41°.

**Note: All motors are oiled and sealed.**

**Note: All self-contained models are shipped from the factory with the service valves open ready for operation.**

**Note: All non-programmable timers are scheduled for 6 defrost cycles (15 minute duration's) in a 24 hour period.**

The legs are equipped with bullet-type leveling bolts. Turn bolts clockwise or counterclockwise until the unit is level (both right to left and front to back). This can be done by hand or with an open end wrench.

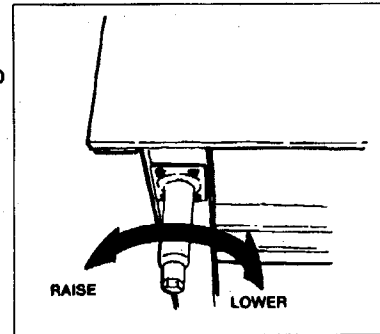
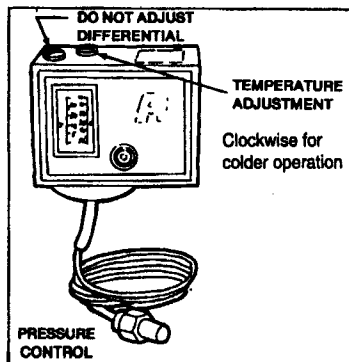
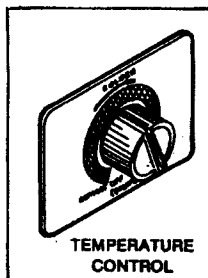

Diagram B - Temperature control adjustments



A control knob allows for adjustments. Turning the knob clockwise will result in increased cooling. Keep the arrow on the knob pointed within the green arc. Turning it clockwise beyond the green can result in freeze-up, while turning it counterclockwise beyond the green will shut the compressor off. If your cabinet temperature remains too warm and your temperature control is at the maximum setting you may need to adjust the pressure control. Your units pressure control should be set at the time of installation by a qualified installation contractor. If minor adjustments are needed at a later date, adjust control by turning the right adjusting screw clockwise (1/4 turn at a time) to a lower number for colder temperature and counterclockwise to a higher number for a warmer temperature.

**Note: Numbers are pounds of pressure not degrees F.**

**Note: Do not adjust the differential screw (Left screw).**

### Diagram C - Resetting self-closing hinge

Loosen set screw, using flat tip screwdriver turn bottom hinge (2) turns. Turn clockwise on left hinged doors, counterclockwise on right hand doors. Hold hinge in wound position with screwdriver and tighten set screw.

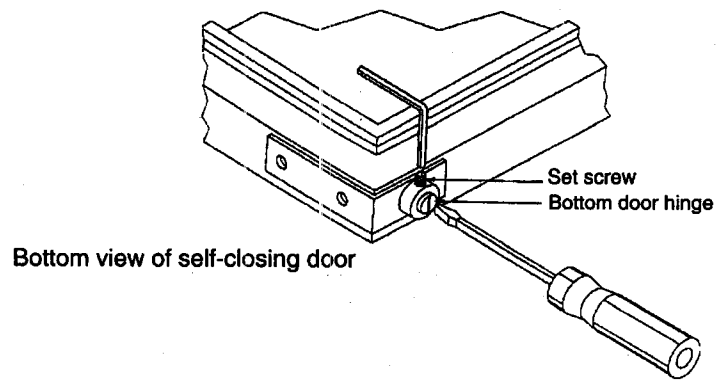

### Diagram D - Door adjustment

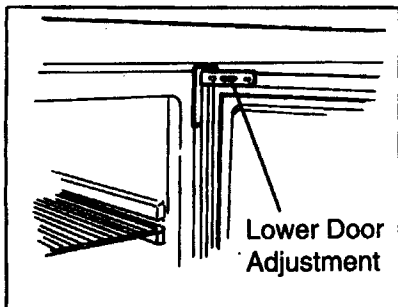

The doors are mounted to the cabinet with two screws on the upper hinge, and a hinge pin on the bottom. To adjust the door first open it 90° and remove the two screws, leaving the center adjusting screw loose enough to reposition door. Once repositioned, install all screws and tighten.

## Unit Operation

Allow your unit to operate for approximately 2 hours before putting in food. This allows the interior to cool down to the correct storage temperature. Randell has attempted to preset the cold control for an average interior temperature of 38°F at the factory but due to varying ambient conditions, including elevation, food product as well as type of operation may alter this temperature. Additional adjustments can be made (within limits) by turning the control dial up or down until the desired temperature is reached. The control dial is located either on the evaporator housing or inside the compressor housing (see diagram B).

Your condiment pans will maintain proper temperatures when utilized properly. It is strongly recommended that the standard hooded roll covers be kept in the closed position when the unit is not in use and between rush periods. It is also a requirement that the standard hooded covers remain on the unit at all times to properly maintain product temperatures. This is especially important in the summer and in kitchens exceeding 80° F.. Do not leave the covers open for prolonged periods of time. Close after using. All individual condiment pans need to be in the rail at all times.

**Note:** If no product is available or necessary fill empty pans with 1" or 2" of water as an insulating barrier.

**Note:** Even though your make table was designed for heavy use, excessive door openings should be avoided, in order to maintain proper box temperature and eliminate the possibility of coil freeze up.

2. Clean all fan blades, both on the condensing unit and the evaporator assembly.
3. Lubricate fan motor shafts and door hinges. Lubricate fan motor shafts with 3-in-1 oil and door hinges with lithium grease.
4. Clean and disinfect drain lines and evaporator pan with a solution of warm water and bleach.
5. Clean all gaskets on a weekly if not daily basis with a solution of warm water and a mild detergent to extend gasket life.

**NOTE: DO NOT USE SHARP UTENSILS**

Recommended cleaners for specific situations

JOB	CLEANING AGENT	COMMENTS
Routine cleaning	Soap, ammonia, detergent Medallion	Apply with a sponge or cloth
Fingerprints and smears	Arcal 20, Lac-O-Nu, Ecoshine	Provides a barrier film
Stubborn stains and discoloration	Cameo, Talc, Zud, First impression	Flub in the direction of the polish lines
Greasy and fatty acids, blood, burnt-on foods	Easy-Off, De-grease It, Oven aid	Excellent removal on all finishes
Grease and oil	Any good commercial detergent	Apply with a sponge or cloth
Restoration/Passivation	Benefit, Super Sheen	Good idea monthly

Reference: Nickel Development Institute, DiverseyLever, Savin, Ecolab, NAFEM

Do not use steel pads, wire brushes, scrapers or chloride cleaners to clean your stainless steel.

**CAUTION: DO NOT USE ABRASIVE CLEANING SOLVENTS, NEVER USE HYDROCHLORIC ACID (MURIATIC ACID) ON STAINLESS STEEL.**

Proper maintenance of equipment is the ultimate necessity in preventing costly repairs. By evaluating each unit on a regular schedule you can often catch and repair minor problems before they completely disable the unit and become burdensome on your entire operation.

For more information on preventive maintenance consult your local service company. Most repair companies offer this service at very reasonable rates to allow you the time you need to run your business along with the peace of mind that all your equipment will last throughout its expected life. These services often offer guarantees as well as the flexibility in scheduling of maintenance for your convenience.

Randell believes strongly in the products it manufacturers and backs those products with one of the best warranties in the industry. We believe with the proper maintenance and use you will realize a profitable return on your investment and years of satisfied service.

**Preventive Maintenance**

Randell strongly suggests a preventive maintenance program which would include the following **Monthly** procedures:

1. Cleaning of all condenser coils. Condenser coils are a critical component in the life of the compressor and must remain clean to assure proper air flow and heat transfer. Failure to maintain this heat transfer will affect unit performance and eventually destroy the compressor. Clean the condenser coils with coil cleaner and/or a vacuum cleaner and brush.

**Note: Brush coil in direction of fins, normally vertically.**

**EASY TO FOLLOW  
TROUBLE SHOOTING CHART  
WITH  
ILLUSTRATIONS**

<b>SYMPTOM</b>	<b>POSSIBLE CAUSE</b>	<b>PROCEDURE</b>
UNIT DOESN'T RUN	1. NO POWER TO UNIT.	1. PLUG IN UNIT.
	2. TEMPERATURE CONTROL TURNED OFF.	2. CHECK TEMPERATURE CONTROL.
	3. TEMPERATURE CONTROL FAULTY.	3. TEST TEMPERATURE CONTROL. SEE #4
	4. COMPRESSOR OVERHEATED.	4. CLEAN CONDENSER COIL. SEE #1
	5. CONDENSER FAN FAULTY.	5. SERVICE CONDENSER FAN MOTOR. SEE #9
	6. OVERLOAD PROTECTOR FAULTY.	6. TEST OVERLOAD. SEE #10
	7. COMPRESSOR RELAY FAULTY.	7. TEST RELAY. SEE #10
	8. DEFROST TIMER FAULTY.	8. TEST DEFROST TIMER. SEE #8
	9. COMPRESSOR FAULTY.	9. CALL FOR SERVICE.
UNIT SHORT CYCLES	1. CONDENSER COIL DIRTY.	1. CLEAN COIL. SEE #1
	2. CONDENSER FAN FAULTY.	2. SERVICE FAN AND MOTOR. SEE #9
	3. COMPRESSOR FAULTY.	3. CALL FOR SERVICE.
	4. OVERLOAD REPEATEDLY TRIPPING.	4. CHECK OUTLET VOLTAGE.
UNIT RUNS CONSTANTLY	1. FROST BUILD UP.	1. DEFROST EVAPORATOR.
	2. POOR DOOR SEAL.	2. CHECK DOOR SEAL. SEE #3
	3. DOOR GASKET DAMAGED.	3. REPLACE GASKET.
	4. CONDENSER COIL DIRTY.	4. CLEAN COIL. SEE #1
	5. CONDENSER FAN FAULTY.	5. SERVICE CONDENSER MOTOR. SEE #9
UNIT NOT COLD ENOUGH	1. TEMPERATURE CONTROL SET TOO HIGH.	1. LOWER SETTING.
	2. TEMPERATURE CONTROL FAULTY.	2. TEST CONTROL. SEE #4
	3. CONDENSER COIL DIRTY.	3. CLEAN COIL. SEE #1
	4. POOR DOOR SEAL.	4. CHECK DOOR SEAL. SEE #3
	5. DOOR GASKET DAMAGED.	5. REPLACE DOOR GASKET.
	6. EVAPORATOR FAN FAULTY.	6. SERVICE EVAPORATOR FAN. SEE #5
	7. EVAPORATOR ICED UP.	7. DEFROST EVAPORATOR. TEST DEFROST HEATER. SEE #6 TEST THERMODISC. SEE #7 TEST DEFROST TIMER. SEE #8
	8. REFRIGERANT LEAKING OR CONTAMINATED.	8. CALL FOR SERVICE.

SYMPTOM	POSSIBLE CAUSE	PROCEDURE
UNIT TOO COLD	1. TEMPERATURE CONTROL SET TOO LOW.	1. ADJUST CONTROL.
	2. TEMPERATURE CONTROL FAULTY.	2. TEST CONTROL. SEE #4
UNIT DOESN'T DEFROST	1. DEFROST HEATER FAULTY	1. TEST HEATER. SEE #6
	2. DEFROST THERMODISC FAULTY.	2. TEST DISC. SEE #7
	3. DEFROST TIMER FAULTY.	3. TEST TIMER. SEE #8
MOISTURE AROUND DOOR OR FRAME.	1. BREAKER STRIPS FAULTY.	1. INSPECT STRIPS.
	2. FRAME HEATER DEFECTIVE.	2. CALL FOR SERVICE.
	3. TEMPERATURE SET TOO LOW	3. RAISE SETTING.
ICE IN DRAIN PAN OR WATER IN BOTTOM OF UNIT OR FLOOR	1. DRAIN TUBE CLOGGED.	1. CLEAN DRAIN. SEE #2
	2. UNIT NOT LEVEL	2. ADJUST LEVELING FEET.
UNIT NOISY	1. UNIT NOT LEVEL	1. ADJUST LEVELING FEET.
	2. COMPRESSOR MOUNTINGS LOOSE OR HARDENED.	2. TIGHTEN OR REPLACE COMPRESSOR MOUNTINGS.
	3. CONDENSER FAN DAMAGED OR FITTING FAN SHROUD.	3. INSPECT CONDENSER FAN. SEE #9
	4. EVAPORATOR FAN DAMAGED OR HITTING FAN SHROUD.	4. INSPECT EVAPORATOR FAN. SEE #5

### 1. Cleaning condenser coil.

An accumulation of dirt and dust prevents the condenser coil from removing, making your unit cool poorly, run constantly, or even stop completely if the compressor overheats. Clean coil using a vacuum cleaner with a wand attachment. If the coil is greasy, wash it with warm soapy water and a bristle brush, taking care not to drip water on other parts of your unit.

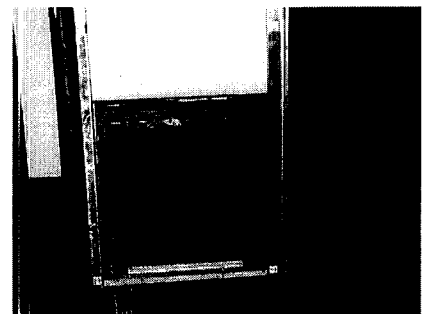

### 2. Cleaning drain and drain pan

Clean the drain using an oven baster to force a solution of hot water and baking soda or bleach into the opening. To clear a stubborn clog, insert a length of 1/4" round plastic tubing into the drain and push it through to the drain pan, then pull it out. Wash the pan regularly with a solution of warm baking soda and water.

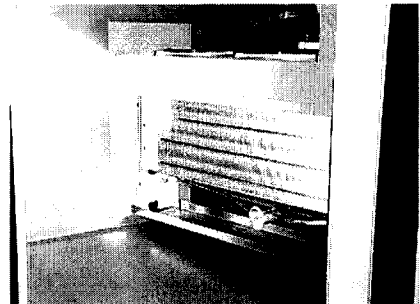

### 3. Checking the door seal.

Open the door and examine all four sides of the door gasket for tears. Feel the gasket for brittleness or cracks. If the gasket shows damage replace it. If not, close the door and check the seal between gasket and cabinet for obvious gaps. Next open the door and shut it on a dollar bill then slowly pull it out of the door. If the gasket seals properly, you will feel tension as it grips the bill. Repeat this test all around the door. If the gasket doesn't seal tightly, replace gasket after first checking the door for sagging, warping.

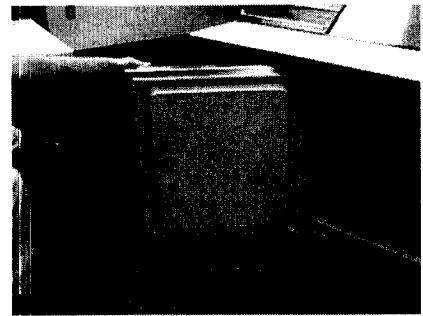

### 4. Testing and replacing the temperature control.

Unplug the unit and remove the temperature control knob. Remove the screws securing the fan shroud to the evaporator coil assembly, next remove the screws securing the temperature control to the fan shroud. Taking care not to bend the capillary line, pull off the wire connectors. Now you are ready to test for continuity. Set your multimeter at RX1, Touch a probe to each terminal. With the control at its coldest setting, the tester should indicate a closed circuit. Turn off the control then retest; the tester should indicate an open circuit. To install a new temperature control, pull the capillary line of the old control out of its opening. Set the new control to its coldest setting and carefully thread the capillary line into the opening without kinking it. Attach the wires to the terminals, screw the control in place and reattach the dial.

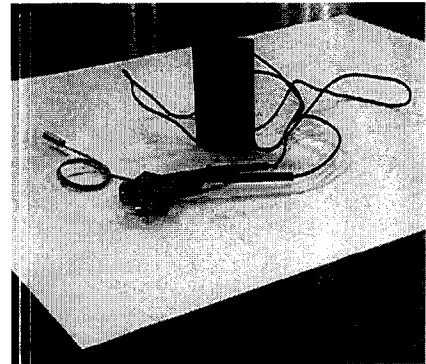

### 5. Checking and testing the evaporator motor.

Remove the screws attaching the fan shroud to the evaporator coil housing. Lift the fan assembly a few inches and disconnect the push on connectors and the ground wire. Check blade for damage, replace if necessary. Pull the blade of the motor shaft and slide on a new blade, taking care not to reverse the blade. Hold the blade horizontally and spin the blade to check for binding in the motor. If the blade does not spin freely, replace the motor. To test the motor set a multimeter at RX1 and touch a probe to each motor terminal. The meter should show resistance. If not, install a new motor, and reinstall the fan.

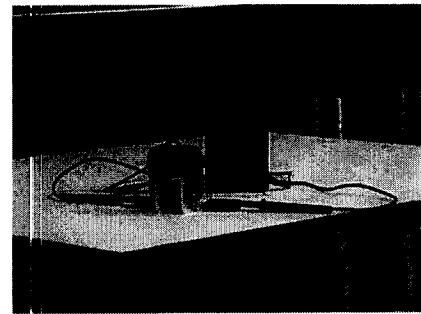

### 6. Testing the defrost heater.

Unplug the unit and remove the evaporator shroud cover. Pull the wire connectors from the terminal at each end of the defrost heater. Set the multimeter at RX1 and attach a probe to each terminal. The meter should show medium to high resistance depending on the wattage of the element. If not replace the element. If the element is good, test the Thermodisc.

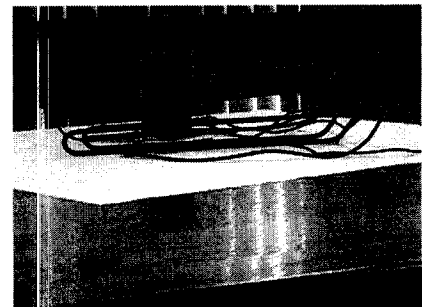

### 7. Testing and replacing the Thermodisc.

The defrost high limit switch (thermodisc) turns off the defrost heater when all the frost has melted during the defrost cycle. To reach it unplug the unit and remove the evaporator fan shroud. The thermodisc is permanently wired, to test bare the wires. Taking care not to cut or fray the metal strands, use a sharp utility knife to remove a small patch of the plastic insulation around each wire. The switch should have complete continuity when it is cold, and no continuity when it is warm.

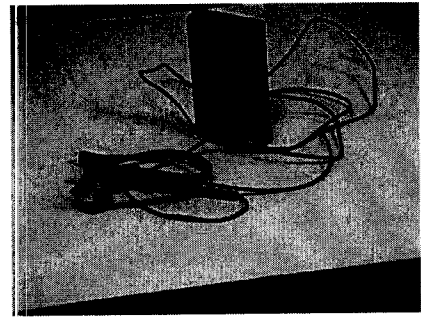

To test the thermodisc warm it using a hair dryer set on low. The multimeter needle should swing down scale to show resistance. If the thermodisc fails test, replace it. If the thermodisc is good reseal the exposed wires with electrical tape, covering the cut and one inch on each side. If the thermodisc is faulty, cut the wires at the bared spots. Splice them to the wires of the new thermodisc using wire caps or crimp connectors waterproofed with a dab of silicone sealant. Snap the new thermodisc in place and reinstall evaporator cover.

### 8. Testing and replacing the non-programable defrost timer.

To test the defrost timer unplug unit. Remove the defrost timer, from the unit. Unscrew the timer from its bracket. The timer is linked to the unit by four color coded wires with push on connectors. To help you reconnect the wires in the proper position, write down the color of the wire next to the corresponding number that is stamped on the side of the timer.

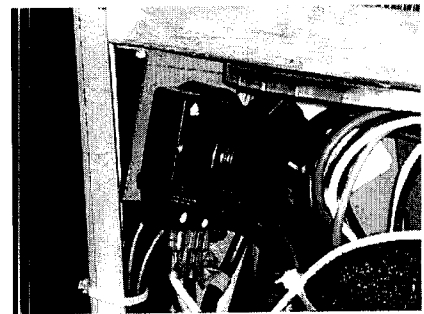

To test the defrost timer find the common terminal #3 (white wire). Attach one multimeter tester probe to the common terminal and, with the meter set at RX100, touch the other probe to each of the other three terminals. One (black) and two (red) should have continuity, while number 4 (blue) should have no continuity.

Then, using a screwdriver, turn the defrost timer switch manually until you hear a click. Test the timer again the same way. One (black) and four (blue) should have continuity, while number 2 (red) should not. In either test, if all three pairs have continuity, or if only one does, the defrost timer is faulty. To install a new one or to reinstall the old one, reconnect the four wires and Reattach the defrost timer to its bracket.

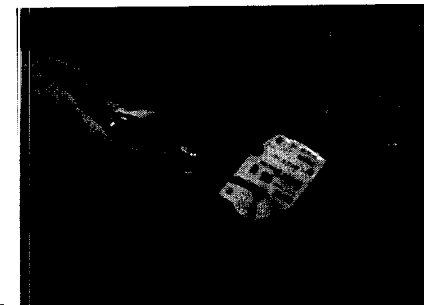
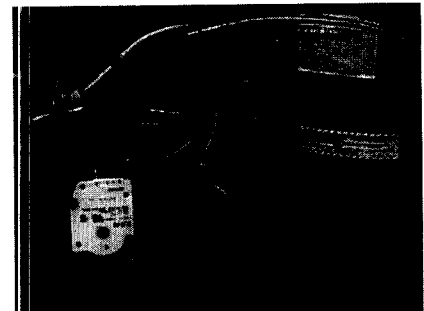

### 9. Servicing the condenser fan.

Inspect the condenser fan motor by removing the mechanical housing cover to gain access. Unplug the unit. Clean the fan blade, and turn it to see if the blade rotates freely. If the motor binds, replace it. If the blade is damaged, unscrew the nut that holds it to the motor shaft and pull it off. Install a new fan blade, replacing any washers, and tighten the nut. To test the condenser fan motor disconnect the wires to the fan motor. Set a multimeter at RX10 and touch one probe to each terminal. The multimeter needle should show approximately 45 to 50 ohms resistance; a lower reading means the rotor is faulty.

Next set the meter at RX1000 and touch one probe to the motor terminals and the other one to any unpainted metal part of the unit. If the meter needle moves, the motor is grounded and should be replaced. To remove the motor unscrew the bracket that holds the fan motor to its housing, slide the motor out of the housing. Remove the fan blade from the old motor and attach it to the new motor, replacing any washers. Install the new motor in its housing by screwing the bracket in place. Reattach the wires to the motor terminals and reconnect the ground wire.



#### 10. Servicing the compressor.

The compressor is part of the sealed refrigeration system and should be replaced by a professional service technician. You can, however, test the compressor and certain components. Unplug the unit and remove the access cover to the mechanical housing. A small box mounted on the side of the compressor protects the relay, overload protector and capacitor. Release the wire retaining clip that holds the cover in place and slip off the cover and the clip.

To test the compressor relay pull the relay straight off the compressor without twisting it. If the relay has an external wire coil, hold the relay so that the word top is up. Set the multimeter at RX1 and place the probes on the terminals S and M. the multimeter needle should not move. Next remove the probe from M and place it on the side terminal marked L. once again, the needle should not move. Finally, remove the probe from S and place it on M. the needle should sweep across the scale, showing full continuity. Now turn the relay upside down and perform the same tests. You should get the opposite results: continuity between terminals S and M and between S and L; no continuity between M and L. if the relay fails any of these tests, replace it: push the new relay onto the compressor terminals and replace the terminal cover. If the relay passes these tests, test the overload protector. To remove the overload protector use a screwdriver to gently pry open the circular spring clip that secures the overload protector to the compressor and snap out the protector. Pull the two wire connectors off their terminals.



To test set a multimeter at RX1 and touch a probe to each overload protector terminal. The multimeter needle should sweep across the scale, showing full continuity. If the overload protector passes this test, test the compressor. If not replace the overload protector. Reattach the push-on connectors to the new overload protector, clip it in place on the compressor and replace the terminal cover.



To test the compressor set a multimeter at RX1, test each of the three terminal pins against each of the other two. Each pair should show continuity. Then, with the multimeter set at RX1000, place one probe against the metal housing of the compressor; if necessary, scrape off a little paint to ensure contact with bare metal. Place the other probe on each of the three terminals in turn. If any of the three terminals shows continuity with the housing, the compressor is grounded. If the compressor fails either test, call for service. If it passes the tests, reinstall the overload protector, relay, terminal cover and mechanical housing cover.

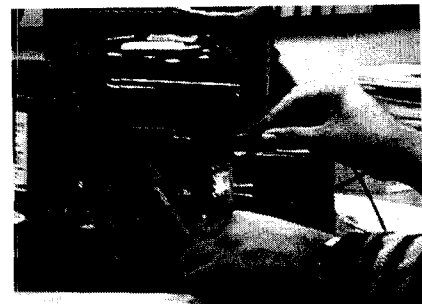

PARTS LIST  
FOR  
RANDELL  
9000K-7 SERIES  
HIGH VOLUME PREPARATION TABLES

9000K-7 SERIES		
ITEM	DESCRIPTION	RANDELL PART #
1	LEG SET (SET OF 4)	HD LEG016
2	LEG	HD LEG010
3	CASTOR SET	001453
4	NON LOCKING CASTOR	HD CST060
5	LOCKING CASTOR	HD CST 061
10	CUTTING BOARD, 50" X 10" X ½"	PL CTB050
10A	CUTTING BOARD, 62" X 10" X ½"	PL CTB062
10B	CUTTING BOARD, 74" X 10" X ½"	PL CTB074
10C	CUTTING BOARD, 86" X 10" X ½"	PL CTB086
11	CUTTING BOARD PIN	HD PIN2030
12	Z-CLIP	RP CLP005
13	PILASTER	RP PIL014
13A	PILASTER, CENTER SUPPORT 9030,9040K7	RP PIL015
14	SHELF 13 1/8" X 25 1/4"	HD SHL015
14A	SHELF 19 1/8" X 25 1/4"	HD SHL060
14B	SHELF 22" X 25.375"	HD SHL405
15	SHELF SUPPORT	HD SPT9000
18	SHELF CLIP	HD CLP100
40	DOOR RIGHT HAND, 23 3/4" X 26"	RP DOR25R
40A	DOOR RIGHT HAND, 17 3/4" X 26"	RP DOR25R
40B	DOOR RIGHT HAND, 26.5" X 26"	RP DOR28R
41	DOOR LEFT HAND, 23 ¾" X 26"	RP DOR25L
41A	DOOR LEFT HAND, 17 ¾" X 26"	RP DOR25L
41B	DOOR LEFT HAND, 26.5" X 26"	RP DOR28L
44	GASKET, DOOR 15 1/4" X 24 1/4"	IN GSK143
44A	GASKET, DOOR 21 1/4" X 24 1/4"	IN GSK161
44B	GASKET, DOOR 24.25" X 24.50"	IN GSK175
46	DOOR HINGE ASSY	HD HIN028
47	DOOR HANDLE	HD HCL037
48	DOOR BUSHING	HD BSH050
48	DOOR BUSHING	HD BSH050
49	DOOR LOCK W/KEY	HD LCK 505B
60	DRAWER ASSEMBLY 18"	RP DWR019
60A	DRAWER ASSEMBLY 24"	RP DWR025
60B	DRAWER ASSEMBLY 27"	RP DWR028
61	DRAWER FRONT 18"	RP FRF019
61A	DRAWER FRONT 24"	RP FRF025
61B	DRAWER FRONT 27"	RP FRF028
62	DRAWER FRAME ASSEMBLY 18"	RP FRM918
62A	DRAWER FRAME ASSEMBLY 24"	RP FRM924
62B	DRAWER FRAME ASSEMBLY 27"	RP FRM927
63	DRAWER TRACK 18"	RP TRK918
63A	DRAWER TRACK 24"	RP TRK924

9000K-7 SERIES		
ITEM	DESCRIPTION	RANDELL PART #
63B	DRAWER TRACK 27"	RP TRK927
66	DRAWER BEARING	HD BRG100
67	DRAWER LINER 12" X 20" X 4"	HD PAN064
68	GASKET, DRAWER 10 3/4" X 15 1/4"	IN GSK103
68A	GASKET, DRAWER 10 3/4" X 21 1/4"	IN GSK104
68B	GASKET, DRAWER 10 3/4" X 24 1/4"	IN GSK105
102	LOUVER " X 26.5"	RP LVR034
102A	LOUVER 16" X 26.5"	RP LVR045
104	LOUVER MOUNTING CLIPS	RP LCH100
105	LOUVER MOUNTING BRACKET	RP BRK345
108	EXPANSION VALVE 1/8 TON R134A	RF VLV200
116	REFRIGERATION CONTROL	HD CNT200
130	CONDENSING UNIT	RF CON503
130A	CONDENSING UNIT	RF CON333
131	COMPRESSOR	RF CMP020
131A	COMPRESSOR	RF CMP200
134	START COMPONENTS	RF STR503
134A	START COMPONENTS	RF STR333
135	RECEIVER TANK 1/3 HP	RF TNK001
135A	RECEIVER TANK 1/2 HP	RF TNK002
136	CONDENSER COIL	RF COI503
136A	CONDENSER COIL	RF COI333
137	CONDENSER MOTOR W/BLADE 810M006B45	RF FAN001
137A	CONDENSER MOTOR W/BLADE 810M009B48	RF FAN014
138	CONDENSER FAN BLADE 51510	RF FAN333A
138A	CONDENSER FAN BLADE 51551	RF FAN502
140	FILTER DRIER	RF FLT250A
150	EVAPORATOR COIL ASSEMBLY	RP CSY101
152	EVAPORATOR COIL	RF COI125
153	EVAPORATOR DRAIN PAN 4.25" X 25	RP PAN9000
154	EVAPORATOR DRAIN TUBE	RP TUB9000
157	EVAPORATOR SIDE SHROUD	RF SHD9000
158	EVAPORATOR FAN MOTOR	EL MTR590
159	EVAPORATOR FAN BLADE	RF FAN006
201	HOOD ASSEMBLY FOR 9030K-7	RP PCR973
201A	HOOD ASSEMBLY FOR 9040K-7	RP PCR974
201B	HOOD ASSEMBLY FOR 9045K-7 & 9050K-7	RP PCR975
202	LID SLIDES AND SUPPORT BAR	HD RCD100
203	CENTER LID SLIDES AND SUPPORT BAR	HD RCD200
204	LID FOR RAIL 41.5"	RP LID042
204A	LID FOR RAIL 28.25"	RP LID028
205	LOCATOR PIN FOR RAIL HOOD	HD PIN001
210	ADAPTER BAR, 20" X 7/8"	RP BAR07K
210A	ADAPTER BAR 12'	RP BAR069
211	ADAPTER BAR SUPPORT BRACKET 9030K7	RP BRK001
211A	ADAPTER BAR SUPPORT BRACKET 2 PAN	RP BRK002
211B	ADAPTER BAR SUPPORT BRACKET 3 PAN	RP BRK003

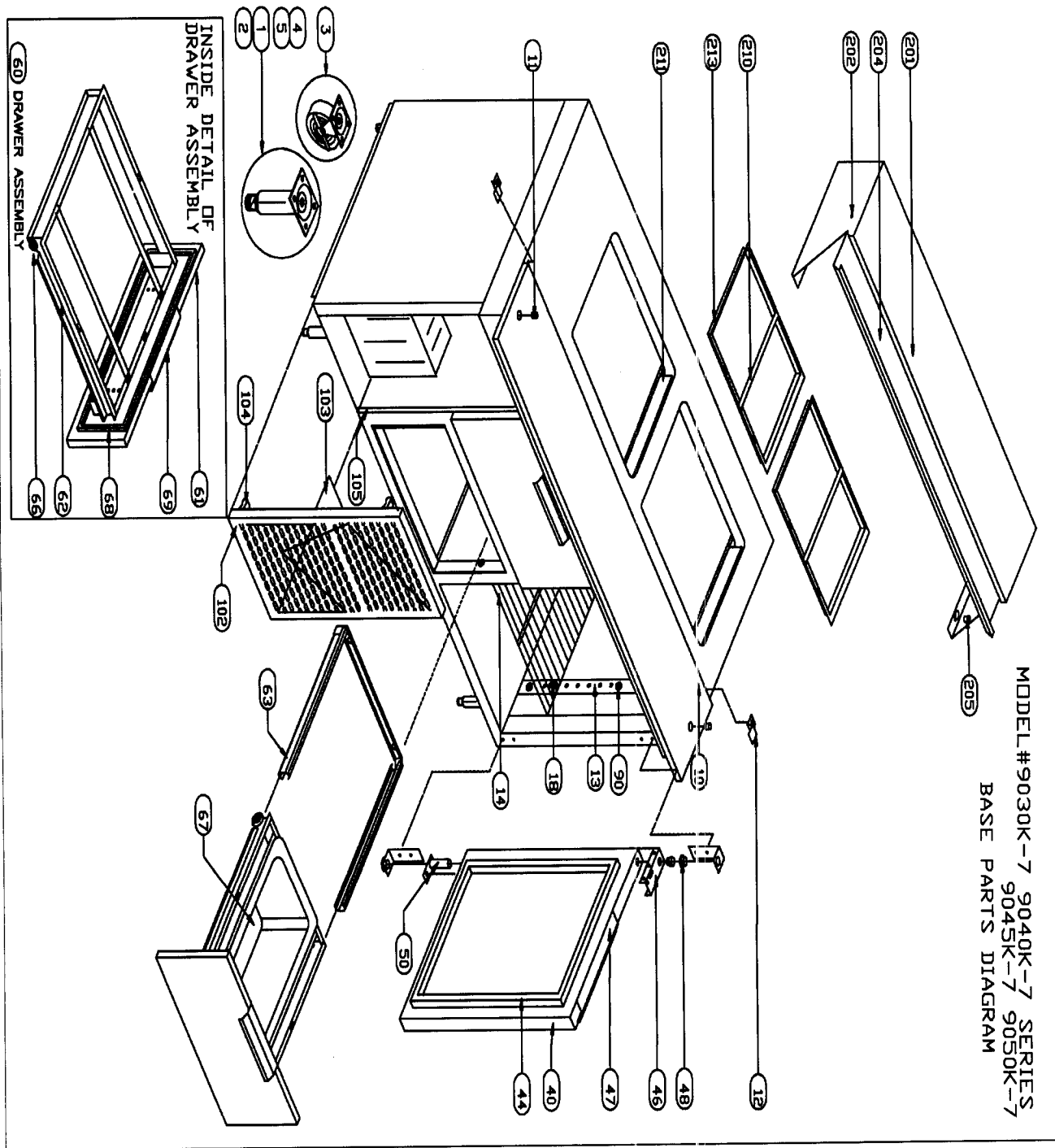

MODEL#9030K-7 9040K-7 SERIES  
 9045K-7 9050K-7  
 BASE PARTS DIAGRAM

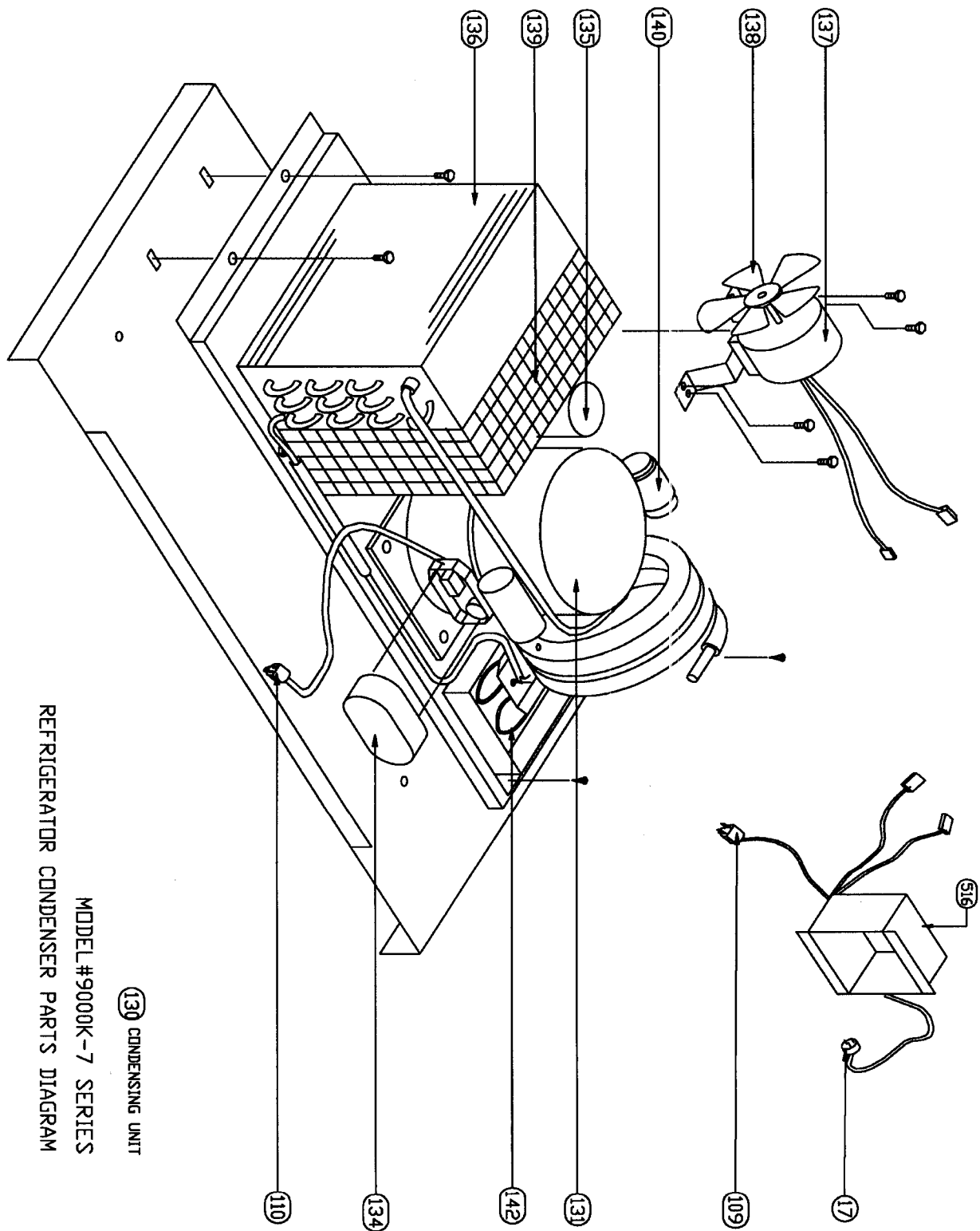

MODEL #9000K-7 SERIES  
REFRIGERATOR CONDENSER PARTS DIAGRAM

MODEL #9030K-7 9040K-7 SERIES  
 9045K-7 9050K-7  
 BASE PARTS DIAGRAM

