

Custom Remote Raised Coldwall Refrigerator models 53000PR

- model 53333PR 53336PR 53339PR 53342PR 53351PR 53354PR 53357PR
 53360PR 53363PR 53372PR 53375PR 53378PR 53381PR 53384PR
 53390PR 533105PR 533117PR

Description:

Remote refrigerator storage units with mechanically cooled raised rail. These units are offered in variety of lengths to meet your specific base storage or pan storage requirements. The mechanically cooled pan opening uses Randell's exclusive design technologies, such as our Exclusive Refrigerated Raised Rail Thermostat allowing customers to make adjustments to the rail temperatures (independent of the base). The rail is designed to be a manual defrost system and allows the operator to shut the rail off while leaving the base operational.

Specifications:

CABINET EXTERIOR: Top to be one piece of die-formed 16 gauge stainless steel with 2 1/2" nosing. Ends at top fitted with recessed heavy duty steel bars for field bolting units together, producing a hairline seam. Hinged louver panel to be stainless steel. Exterior body to be corrosion resistant steel. Door opening frames are ABS and contain magnetic strip for positive seal of door gaskets. Work surface to be at 36" work height. Legs to be 6" high stainless steel with adjustable bullet foot. Legs mounted to full length channel frame assembly which is integrally welded to bottom of body assembly. Legs can be moved left to right to avoid floor obstacles during installation.

CABINET INTERIOR: Base interior to be ABS thermoplastic at ends only. Stainless steel interior liner to be coved cornered to form bottom, back and top. One baked enamel finished shelf provided behind each door. Unit insulation to be CFC free foamed in place urethane.

DOORS: Door fronts to be 22-gauge stainless steel exterior front with 16 gauge stainless steel door pulls/handles. The interior liner is vacuum formed ABS with integral gasket retainer for easy cleaning and accepts Randell's Exclusive Press Fit Gasket system. Doors are mounted on concealed hinges. One removable wire shelf is supplied behind each door.

REFRIGERATION: Refrigerant to be specified by customer (Specification based on R-404a refrigerant). System is a balanced heavy duty system set-up to accept hook-up to a single compressor system. The base is cooled by an independent blower coil operating on its own expansion valve and thermostat and operates through a dedicated solenoid valve. The rail is provided with its own rail thermostat (located in the mechanical housing) making it easily adjustable for specific ambient conditions without effecting the balance of the system. An on/off switch for the rail is provided. Optional electric condensate evaporator.

model 53354PR shown with optional finished end



Standard Features:

- Low profile rail design with 2" recess pans provides easy reach and optimal pan temperatures & reliability
- Front breathing mechanical housing with directed air flow-Randell Exclusive
- Easy maintenance Press-Fit gaskets- A Randell Exclusive
- Raised rail thermostat- A Randell Exclusive
- Drain in rail for easy cleaning
- Hinged Removable stainless steel covers
- Foamed in place urethane insulation providing superior insulation and durability
- 6" high adjustable legs, moveable left to right if needed
- Available up to 16' under one common assembly
- Adapter bars are standard to accommodate a compliment of 1/6 size pans

Options & Accessories:

- Patented Drawer Cartridge Systems - **Exclusive Randell Feature + 3 years parts & labor warranty!**
- Partial Length Rails
- Tray racks for sheet pans (33" dp., 24" doors only)
- Cutting boards
- Stainless Steel Ends
- Stainless Steel Back
- Laminate fronts, ends and back options
- Casters in lieu of legs
- Export voltages
- Over-shelving storage options
- Lift-off (removable) night covers
- Hinged slide-back removable covers
- Flat top rails for use in display type kitchens
- Ambient fighting hood design with slide-back covers
- Wide pan rail

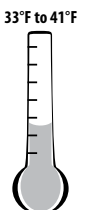

53000PR SERIES REMOTE REFRIGERATORS WITH STANDARD DEPTH RAISED RAIL

Length	33"	36"	39"	42"	51"	54"	57"	60"	63"
Model 33"	53333PR	53336PR	53339PR	53342PR	53351PR	53354PR	53357PR	53360PR	53363PR
# of doors (9" mech.)	(1) 24"	(1) 21" + 6" coil hsg.	(1) 24" + 6" coil hsg.	(1) 27" + 6" coil hsg.	(2) 21"	(1) 21", (1) 24"	(2) 24"	(1) 24", (1) 27"	(2) 27"
# Pans	(6-8) 1/6	(6-8) 1/6	(6-10) 1/6	(6-10) 1/6	(6-12) 1/6	(6-14) 1/6	(8-14) 1/6	(8-16) 1/6	(10-16) 1/6
Min. Length of Rail	27"	27"	27"	27"	27"	27"	34"	34"	41"
Storage Cu. Ft. 33"	4.63	5.50	6.37	7.23	9.84	10.71	11.57	12.44	13.31
Storage Cu. Ft. 29"	3.89	4.62	5.35	6.08	8.26	8.99	9.72	10.45	11.18
Work surface Depth 33"	14.8" wide	14.8" wide	14.8" wide	14.8" wide	14.8" wide	14.8" wide	14.8" wide	14.8" wide	14.8" wide
Recommended H.P./Refrigerant	1/3hp/404a	1/3hp/404a	1/3hp/404a	1/3hp/404a	1/3hp/404a	1/3hp/404a	1/3hp/404a	1/3hp/404a	1/2hp/404a
Amps	5.0	5.0	5.0	5.0	5.0	5.0	5.0	5.0	5.0
Volt/Cycle/Phase	115/60/1	115/60/1	115/60/1	115/60/1	115/60/1	115/60/1	115/60/1	115/60/1	115/60/1
Ship Wt. - lbs.	400	419	438	475	494	513	544	563	619
BTU Design load*	302/455	302/492	378/529	378/566	454/840	529/877	529/914	605/950	930/1051
Evap BTU/TD *Rail/Base	23/120	23/120	23/120	31/120	31/120	35/120	35/120	35/120	605/987

Length	72"	75"	78"	81"	84"	90"	105"	117"
Model 33"	53372PR	53375PR	53378PR	53381PR	53384PR	53390PR	533105PR	533117PR
# of doors (9" mech.)	(3) 21"	(2) 21", (1) 24"	(2) 24", (1) 21"	(3) 24"	(2) 24", (1) 27"	(3) 27"	(4) 24"	(4) 27"
# Pans	(10-16) 1/6	(10-16) 1/6	(10-18) 1/6	(10-20) 1/6	(12-20) 1/6	(12-22) 1/6	(14-24) 1/6	(14-28) 1/6
Min. Length of Rail	41"	41"	41"	41"	48"	48"	55"	55"
Storage Cu. Ft. 33"	15.91	16.78	17.65	18.52	19.39	21.12	25.46	27.78
Storage Cu. Ft. 29"	13.37	14.10	14.83	15.56	16.28	17.74	21.39	23.33
Work surface Depth 33"	14.8" wide	14.8" wide	14.8" wide	14.8" wide	14.8" wide	14.8" wide	14.8" wide	14.8" wide
Recommended H.P./Refrigerant	1/2hp/404a	1/2hp/404a	1/2hp/404a	1/2hp/404a	1/2hp/404a	1/2hp/404a	3/4hp/404a	3/4hp/404a
Amps	5.0	5.0	5.0	5.0	5.0	5.0	5.0	5.0
Volt/Cycle/Phase	115/60/1	115/60/1	115/60/1	115/60/1	115/60/1	115/60/1	115/60/1	115/60/1
Ship Wt. - lbs.	638	669	688	706	744	797	819	875
BTU Design load*	930/1080	1033/1109	1033/1138	1033/1167	1137/1226	1182/1275	1343/1517	1550/1633
Evap BTU/TD *Rail/Base	680/1262	756/1299	756/1335	832/1372	832/1409	907/1483	1058/1831	1210/1978

NOTE:

Pan capacity reflected is the actual amount of pans that are clearly accessible by the operator. Units with multiple covers may actually have additional pan capacity that is partially obstructed by the cover divider/mullion. Remote rails intended to be connected to separate low-temp system, can be as small as (6) pans on any size base.

*BTU load and capacity ratings based on 100F ambient plus 30% for usage and product loading in base. Final system selection should consider usage requirements and combined loads. Recommended HP applied to self-contained (single) unit of equal storage capacity; increased HP may be appropriate in some remote applications.

Evaporator BTU/TD reflects NSF refrigerated base requirements when base is provided with +20F system separate from -10F rail system.





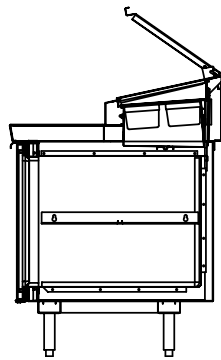
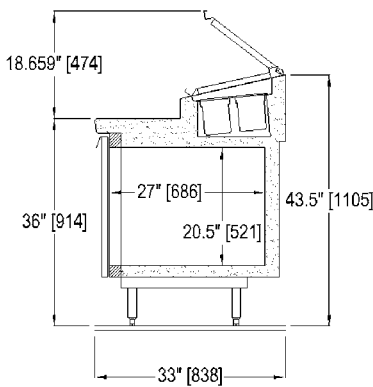
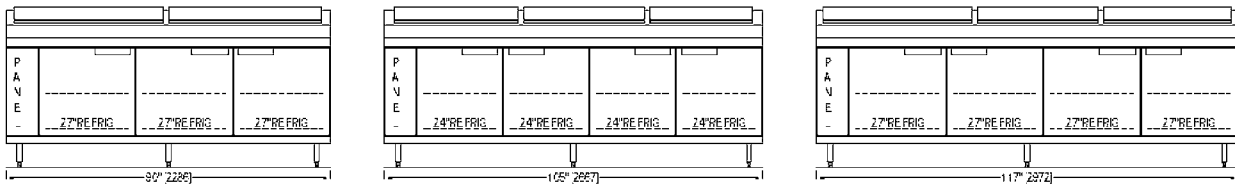
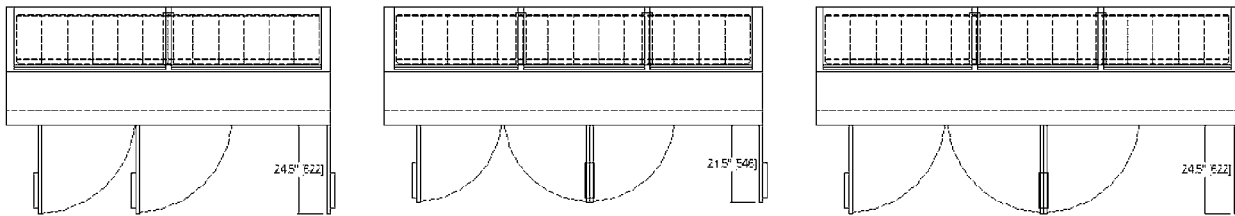
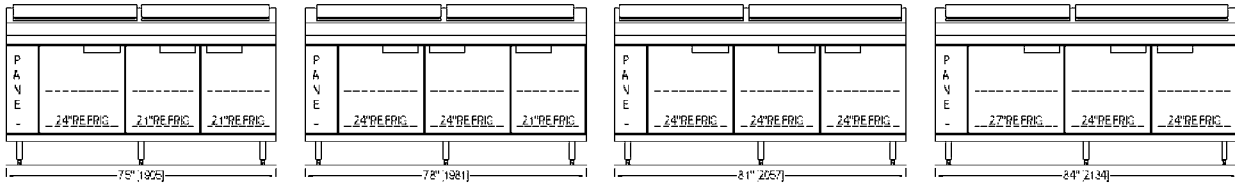
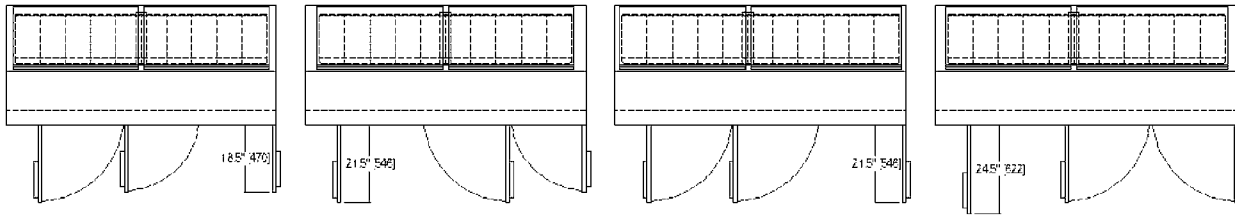

SECTION VIEW

DOOR OPENING SIZES - INTERIOR DEPTHS

Door Width	Clearances Through Door		Interior Depth Behind Door (unit depths in parentheses)
	Lt. to Rt.	Top to Bottom	
18"	13 1/4"	20 1/4"	(33")-26" (29")-22" (22")-15.5"
21"	16 1/4"	20 1/4"	(33")-26" (29")-22" (22")-15.5"
24"	19 1/4"	20 1/4"	(33")-26" (29")-22" (22")-15.5"
27"	22 1/4"	20 1/4"	(33")-26" (29")-22" (22")-15.5"

• Shelf depth is 25 1/4" on 33" deep equipment, 21 1/4" on 29" deep equipment, and 14 1/2" on 22" deep equipment.

