



Reach-In Pass-Thru Double Door Refrigerator models 2020P

model 2020P (Stainless Steel Doors) 2021P (Glass Doors)

Description:

Randell Series 2000 Reach-In are built for years of efficient, high performance service. The top mounted, expansion valve refrigeration system offers the highest, most consistent performance available while maximizing usable interior space.

Finishes:

- Standard Series Doors/Louwer:** Stainless steel.
Exterior Sides: Anodized aluminum. **Interior:** Anodized aluminum
- E Series** Cabinet interior, exterior sides, fronts, and doors stainless steel.

Specifications:

CABINET EXTERIOR: Cabinet body is constructed of all metal, inside & out. The top and bottom are galvanized steel. Fronts and sides are available in finishes as listed above. Doors and louvers are stainless steel and are removable without tools. Unit on 6" casters, front two are locking.

CABINET INTERIOR: Interior of cabinet is fully covered to meet N.S.F. standard #7. The interior walls, ceiling and door liner are available in either stainless steel or anodized aluminum as listed above. Foamed in place, CFC free urethane insulation. Snap-in A.B.S. breaker strips allow access to condensate heater wires.

DOORS: Stainless steel fronts with either anodized aluminum or stainless steel liner, mounted on heavy duty cam lift hinges with automatic light switch, heavy duty chrome handle, cylinder door lock. Glass doors to be insulated glass with bright extruded aluminum frames, switch for interior light mounted on exterior of glass door unit.

REFRIGERATION: Top mounted condensing unit and evaporator coil, expansion valve system with thermostatic control, factory tested and balanced to maintain 38° F. average interior temperature utilizing CFC free 134a refrigerant. Evaporator coil is coated to resist corrosion. Unit supplied with master on/off switch and 8' cord and plug. Access to service points without tools is standard.

Standard Features:

- Expansion Valve
- Exterior LED Temperature Display
- Top mounted Compressor & Evaporator Coil
- C.F.C. Free R-134a Refrigerant
- Efficient Hot Gas Condensate Evaporator



Standard Features Continued:

- Automatic Defrost
- 8' Cord & Plug
- Main Power Supply Switch
- Self-Closing Cam Lift Hinges with 120° Open Feature (Lifetime Warranty)
- Automatic Interior Light
- 6" Casters - Factory Mounted (Front two Locking)
- Cylinder Door Locks
- Fully Coved Interior Meeting N.S.F. Standard #7
- Polyurethane Insulation
- Condensate Heaters Around All Door Openings
- 3 Baked Epoxy Coated Wire Shelves Per Section With Stainless Steel Support Clips (Adjustable every 1")
- Snap-In Magnetic Door Gaskets

Options & Accessories:

- Universal Tray Slides (set of two) Qty. _____ Sets _____
- *1/2 Doors Solid Glass Qty. _____ Location _____
- 6" Legs
- Remote (Add Suffix "R")
- Extra Interior Shelves Qty. _____
(maximum of (23) or (20) additional on 1.5" centers-leaves 1" clear)
- Finished Back
- Export Voltage(s) Specify Voltage _____
- Prison Package

*Split glass door option available on model 2021P only.

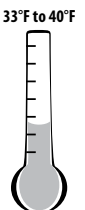

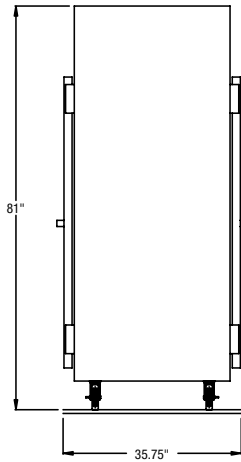
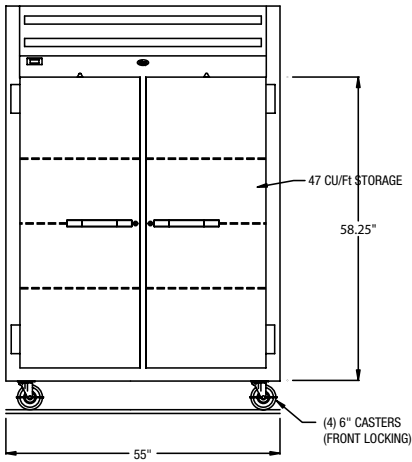
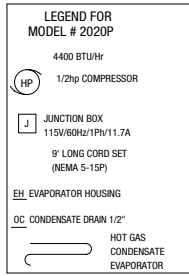
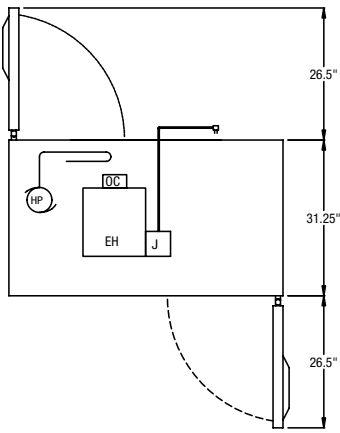

TRAYSLIDE CAPACITIES

Universal Pan Slides Model....RIUNIVPS - set of two.
For 12 x 20 food pans or 18 x 26 sheet pans.

Maximum capacity of 12" x 20" food pans per full height section:
(6) 6" deep pans, (8) 4" deep pans, (18) 2" deep pans.

Maximum capacity of 18" x 26" sheet pans with 2" spacing is (22).

FOR REMOTE MODELS

Use same specifications as self-contained model except for:

Model No.	Rec. H.P.	Rec. BTU/Hr.	Amp.	Ship Wt.
2020PR Pass-Thru	1/3	4400	5	545

Note: All remote Reach-Income standard on 6" legs in lieu of casters.

SELF-CONTAINED SINGLE SECTION REFRIGERATORS

Model	L	D	H	Doors	Cu./Ft.	Shelves	Shelves Sq. Ft.	HP	Volt	Amps	NEMA	BTU Rating	Ship Wt.
2020P solid doors	55"	35 3/4"	81.25"	4	49.50	6	26	1/2	115/60/1	11.7	5-15P	4400*	595
2021P glass doors	55"	35 3/4"	81.25"	4	49.50	6	26	1/2	115/60/1	11.7	5-15P	4400*	595

*Based on 90° ambient and +20° evaporator.

