



# Reach-In Double Door Dual Temperature model 2020D

## Description:

Randell Series 2000 Reach-In are built for years of efficient, high performance service. The top mounted, expansion valve refrigeration system offers the highest, most consistent performance available while maximizing usable interior space.

## Finishes:

- Standard Series Doors/Louwer:** Stainless steel.  
**Exterior Sides:** Anodized aluminum. **Interior:** Anodized aluminum
- E Series** Cabinet interior, exterior sides, fronts, and doors stainless steel.

## Specifications:

**CABINET EXTERIOR:** Cabinet body is constructed of all metal, inside & out. The top, bottom, & back are galvanized steel. Front and sides are available in finishes as listed above. Doors and louver are stainless steel and are removable without tools. Unit on 6" casters, front two are locking.

**CABINET INTERIOR:** Interior of cabinet is fully covered to meet N.S.F. standard #7. The interior walls, ceiling and door liner are available in either stainless steel or anodized aluminum as listed above. Foamed in place, CFC free urethane insulation. Snap-in A.B.S. breaker strips allow access to condensate heater wires.

**DOORS:** Stainless front with either anodized aluminum or stainless steel liner, mounted on heavy duty cam lift hinges with automatic light switch, heavy duty chrome handle, cylinder door lock. Optional glass doors to be insulated glass with bright extruded aluminum frames, switch for interior light mounted on exterior of glass door unit.

**REFRIGERATION:** Top mounted condensing unit and two separate evaporator coils utilizing CFC free 404a refrigerant. Refrigerator section utilizes an expansion valve system with thermostatic control, factory tested and balanced to maintain 38° F. average interior temperature. Freezer section uses an expansion valve system with pressure control, factory tested and balanced to maintain (0° F. to -5° F.) average interior temperature. Evaporator coils are coated to resist corrosion. Unit supplied with master on/off switch and 8' cord and plug. Access to service points without tools is standard.



## Standard Features:

- Expansion Valve
- Digital Control
- Exterior LED Temperature Display
- Top mounted Compressor & Evaporator Coils
- C.F.C. Free R-404a Refrigerant
- Efficient Hot Gas Condensate Evaporator
- Automatic Defrost
- 8' Cord & Plug
- Main Power Supply Switch
- Self-Closing Cam Lift Hinges with 120° Open Feature (Lifetime Warranty)
- Automatic Interior Light
- 6" Casters - Factory Mounted (Front two Locking)
- Cylinder Door Locks
- Fully Coved Interior Meeting N.S.F. Standard #7
- Polyurethane Insulation
- Condensate Heaters Around Freezer Door Opening
- 3 Baked Epoxy Coated Wire Shelve  
With Stainless Steel Support Clips (Adjustable every 1")
- Snap-In Magnetic Door Gaskets

## Options & Accessories:

- Universal Tray Slides (set of two) Qty. \_\_\_\_\_ Sets \_\_\_\_\_
- 1/2 Doors  Solid  Glass Qty. \_\_\_\_\_ Location \_\_\_\_\_
- 6" Legs
- Remote (Add Suffix "R")
- Extra Interior Shelves Qty. \_\_\_\_\_  
(maximum of (23) or (20) additional on 1.5" centers-leaves 1" clear)
- Finished Back
- Export Voltage(s) Specify Voltage \_\_\_\_\_
- Prison Package

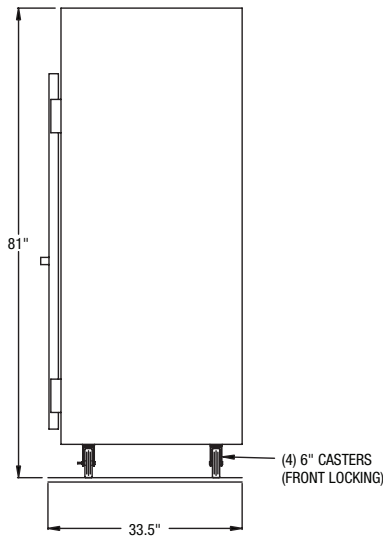
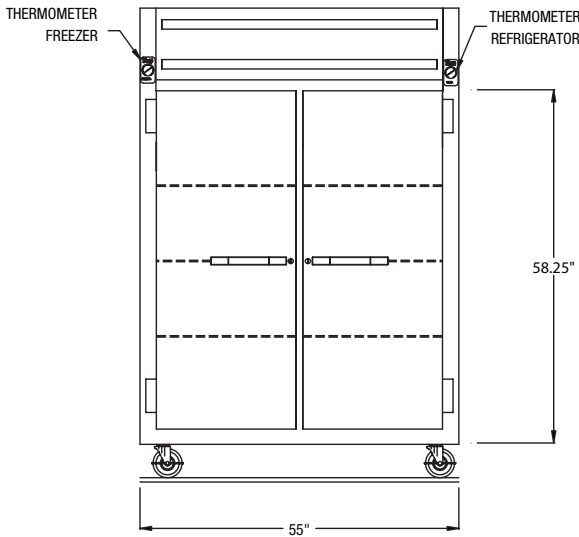
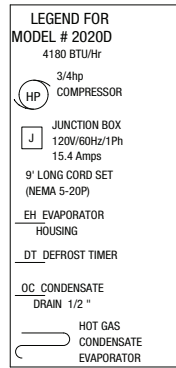
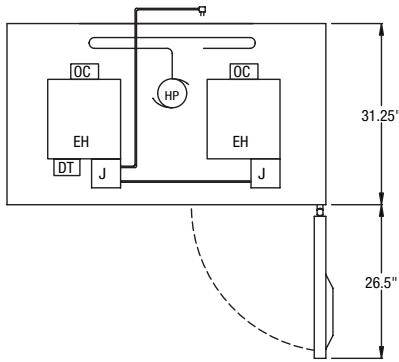

**TRAYSLIDE CAPACITIES**

**Universal Pan Slides .... Model....RIUNIVPS** - set of two.  
For 12 x 20 food pans or 18 x 26 sheet pans.

Maximum capacity of 12" x 20" food pans per full height section:  
(6) 6" deep pans, (8) 4" deep pans, (18) 2" deep pans.

Maximum capacity of 18" x 26" sheet pans with 2" spacing is (22).

FOR REMOTE MODELS				
Use same specifications as self-contained model except for:				
Model No.	Rec. H.P.	Rec. BTU/Hr.	Amp.	Ship Wt.
2020DR solid door	3/4	4180	7	640

Note: All remote Reach-Income standard on 6" legs in lieu of casters.

33°F to 40°F



Refrigerator

0°F to -5°F



Freezer

SELF-CONTAINED, TWO SECTION, DUAL TEMPERATURE REFRIGERATOR/FREEZER													
Model	L	D	H	Doors	Cu./Ft.	Shelves	Shelves Sq. Ft.	HP	Volt	Amps	NEMA	BTU Rating	Ship Wt.
2020D two section	55"	33 1/2"	81.25"	(2) full size	44.3	8**	26**	3/4	115/60/1	15.4	5-20P	4180*	690

\* Based on 90° ambient and +20° evaporator for refrigerator. 90° ambient and -10° evaporator for freezer.

\*\* Includes bottom of each section as one shelf.